

Memristor Hypothesis in Malignant Charge Distribution

Andras Szasz

Department of Biotechnics, St. Istvan University, Budaors, Hungary

Email: biotech@gek.szie.hu

How to cite this paper: Szasz, A. (2023) Memristor Hypothesis in Malignant Charge Distribution. *Open Journal of Biophysics*, 13, 51-92.

<https://doi.org/10.4236/ojbiphy.2023.134005>

Received: August 7, 2023

Accepted: September 24, 2023

Published: September 27, 2023

Copyright © 2023 by author(s) and Scientific Research Publishing Inc.

This work is licensed under the Creative Commons Attribution International License (CC BY 4.0).

<http://creativecommons.org/licenses/by/4.0/>



Open Access

Abstract

Tissues in biological objects from the point of view of electromagnetic effects must be modeled not only for their conductivity. The ionic double layer induced by the electric field, built by electrolytic diffusion, must be counted. The micro (frequency dispersion phenomena) and macro (interfacial polarization), as well as more generalized by Nernst-Planck cells describe the biophysical aspects of this phenomena. The charge distribution depends on the processes and produces charge gradients in space. The dynamic feasibility of the-charge transition layer has memory and adaptability, working like a memristor in cancerous development. The memristor processes may complete the adaptation mechanisms of cancer cells to extremely stressful conditions. Our objective is to show the distribution and redistribution of space charges that generate memristors and internal currents like injury current (IC) in the development of cancer. We show some connected aspects of the modulated electrohyperthermia (mEHT) limiting the proliferation process in the micro-range like the macro-range electrochemotherapy (ECT) processes do. The internal polarization effects form space-charge, which characteristically differ in malignant and healthy environments. The electrical resistivity of the electrolytes depends on the distribution of the charges and concentrations of ions in the electrolytes, consequently the space-charge differences appear in the conductivity parameters too. The polarization heterogeneities caused by the irregularities of the healthy tissue induce a current (called injury current), which appears in the cancerous tumor as well. Due to the nonlinearity of the space-charge production and the differences of the relaxation time of the processes in various subunits. The tumor develops the space-charge which appears as an inductive component in the otherwise capacitive setting and forms a memristive behavior of the tumorous tissue. This continuously developing space-charge accommodates the tumor to the permanently changing conditions and helps the adopting the malignant cells in the new environment. Applying external radiofrequency electric field, the disturbance of the

space-charge may change the conditions, and seek to reestablish the healthy homeostatic equilibrium, blocking the pathologic injury current components. The hypothetical memristive behavior of the tumor microenvironment and the tumor mass may be a biophysical addition to the adaptation mechanisms of tumor cell and could provide a way to block the pathogen biophysical processes. An electric field in the direction of the place of disturbance from the healthy neighborhood appears, starting a current, which promotes cell migrations and wound healing, re-establishing homeostatic equilibrium. In pathological disturbance, the same process starts, which supports further proliferation, so its blocking is desired.

Keywords

Malignancy, Tumors, Memristor, Imperfect Dielectrics, Heterogeneity, Charge Distribution, Injury Current, Nernst-Planck Cell

1. Introduction

Bioelectromagnetism refers to the study of electromagnetic phenomena within living organisms. It encompasses the electrical and magnetic properties of cells, tissues, and organs, as well as it could be used to treat diseases by repairing faulty processes [1]. Endogenous physiological electric fields are an accessible source of physical stimulation in cancer therapy [2] [3]. Electrical stimulation may affect apoptosis and cell proliferation [4] [5], it may induce immune-modulative processes [6], and abscopal effect [7]. While research has explored the effects of electromagnetic fields on cancer cells, the relationship between bioelectromagnetism and cancer cell adaptability is not yet fully understood.

Understanding bioelectromagnetic interactions is at the forefront of many biophysical problems and their clinical applications. Some active electromagnetic treatments as well as diagnostic applications, intensively apply bioelectric phenomena. Complexity is the biggest challenge in bioelectromagnetism. Understanding requires a combined analysis of numerous fields of physics, biology, and medicine.

Biomaterials are highly complex. The role of electric fields in living materials is a fascinating and complex area of study that encompasses various biological processes and phenomena. Electric fields are generated by the movement of charged particles, such as ions, within and around living organisms. These fields play a significant role in several aspects of biological systems:

- Forming cellular membrane potential by electro-diffusive selection forms an intensive electric field. Having in average ~70 mV membrane potential of healthy cells, the electric field in the membrane could be as high as $1 \text{ mV/nm} = 1 \text{ MV/m}$.
- Electric fields are involved in cellular communication, both within individual cells and between neighboring cells. Neurons, for instance, transmit signals

through the generation and propagation of electric impulses, known as action potentials. These electrical signals enable the nervous system to transmit information rapidly across long distances.

- Many cellular processes are governed by ion movements and electric potentials across cell membranes. These processes include the regulation of ion channels, which are responsible for maintaining the proper balance of ions within cells. Ion gradients and electric potentials are crucial for processes like muscle contraction, cell division, and cellular signaling.
- Electric fields are known to influence wound healing. When tissues are injured, they generate electric fields that guide cellular migration and tissue regeneration.
- Electric fields have been found to play a role in tissue regeneration in various organisms. Certain animals, like salamanders, can regenerate lost body parts, and electric fields are believed to contribute to the process by guiding cell movement and tissue growth.
- Electric fields are being explored for their potential in cancer treatment. Electric fields can interfere with cell division, potentially inhibiting the growth of cancerous cells.
- Electric fields can act as signaling cues for cells to change their behavior. For example, during development, electric fields guide the patterning of tissues and organs. These bioelectric signals are believed to work in conjunction with biochemical signals to orchestrate complex processes.
- Electric fields have been shown to influence cell differentiation, the process by which cells become specialized for specific functions. Electric fields can influence the fate of stem cells and direct their differentiation into specific cell types.
- Cells can sense and respond to electric fields by migrating towards or away from them. This phenomenon, known as galvanotaxis or electrotaxis, is observed in various cell types and plays a role in processes like wound healing and development.
- Polarization interactions are one of the crucial factors in the structure of tissues and organs. These are not only crucial in cellular level, but are also active in many electrolytes of the living system, where the structure of water is polarizable, and semi-crystalline. The cancer disorders the electrolyte structure in the cellular vicinity, facilitating its detection. It is likely that the ordered water bound to the membrane is also oriented by the membrane potential and the polarized epithelial plates.

Overall, electric fields are an integral part of living materials, influencing a wide range of biological processes from cellular communication to tissue regeneration. The field of bioelectricity continues to be an area of active research, with ongoing efforts to understand the underlying mechanisms and potential applications in medicine and regenerative biology.

The aqueous multicomponent electrolyte (extracellular matrix, ECM) is an

essential constructional component of living objects is. ECM has ionic species presenting free charges and their flows. Here the polarization effects are accompanied by free-charge conductivity.

Cells, tissues, and organs have internal polarization, which is a crucial factor in the interactions in the living system [8]. All cells have various membranes defining the fundamental functions of the cells. The membrane structures are strictly polarized layers, separating the various electrolytes and governing the selective ionic exchanges. The capacitive electric part is the membrane, which is a selective barrier mixing the various electrolytes, selects the ionic and molecular transports and controls the “deliveries” into the cell. Furthermore, membrane sensors and bonds may profoundly influence the cellular processes with structural and signaling effects and play a decisional role in its fate.

Well-known polarization characterizes many tissues, like epithelial separating adjacent tissues from each other and having a specific role in the homeostasis of organs. Epithelia form a well-structured layer; it is a permanently polarized sheet fixing the post-developed complete organism for its entire life. The human body has definite polarization measured on the skin on the whole body surface [9].

Polarization is fundamental not only in epithelial cells but active in many tissues in the organisms. It arranges the water structure to polarize too, which shows semi-crystalline behavior in this way [10]. It is likely that the ordered water bound to the membrane is oriented by the membrane potential (φ_m), and by the polarized epithelial sheets as well. The actual polarization modifies the dielectric permittivity of the tissues.

The biological cell membrane can filter the external current flow. It critically limits the penetration of the low-frequency currents into the cell but allows high-frequency signals to pass through [11]. The growing frequency increases the capacitive conduction of the membrane. When the frequency is as high as $f > 15$ MHz the capacity becomes a good conductor and practically shortcuts the resistor, while in low-frequencies ($f < 10$ Hz) it appears as a high resistive barrier, the current flows through the resistor. In the intermediate frequency interval, both electric parts actively contribute to the complete resistivity of the tissue. Due to this mechanism, the radio-frequency (RF) current does not flow through the tissue homogeneously, and when the frequency does not exceed 15 MHz the current density differs in the extracellular and intracellular electrolytes (Figure 1).

The absorbed power depends on the σ conductivity ($SAR = \frac{1}{2}\sigma E^2$), while the reactive absorption (\mathcal{W}) periodically goes in and out of the system by double frequency, and depends on the dielectric permittivity ($\mathcal{W} = -\frac{1}{2}\omega\epsilon E^2$), and changes by its heterogeneity.

The cell-membrane representing an essential part of the overall permittivity combines the barrier function between aqueous solutions and the selective conduction between them, controlling the ionic and molecular exchange between

the electrolytes. The control could be passive, driven by the diffusional forces between the different electrolyte concentrations; however there are numerous active transmembrane transports by other gradients like the temperature, voltage, electric and magnetic fields, chemical potential and concentration inhomogeneities (Figure 2). The thermal effect certainly appears in the thermally sensitive channels [12] (Figure 2(A)), but most of the bioelectromagnetic activities are nonthermal. The voltage change activates the voltage gated channels [13] or the voltage sensitive molecules like VSPs [14] (Figure 2(B)). The magnetic field [15] and electric field [16] proceed ion cyclotron resonance (Figure 2(C)). The diffusion is driven with the concentration gradient, which could be thermal, or

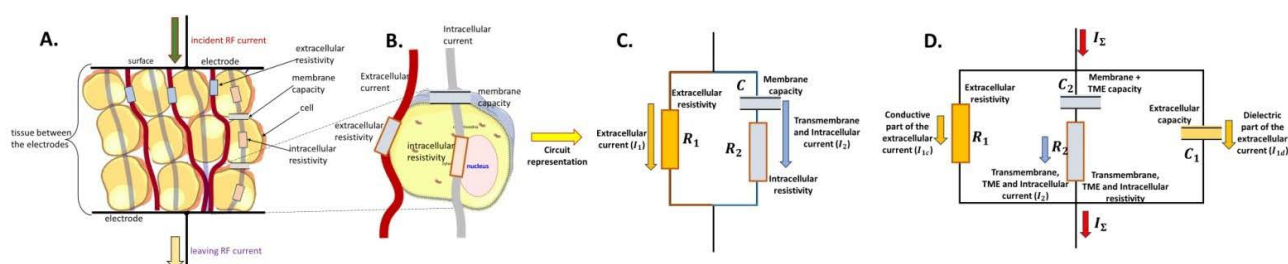

Figure 1. The RF current flow in tissues. The intracellular and membrane resistance are connected in serial mode, so they may be added together. (A) It selects between the extracellular and intracellular electrolytes in the range of radiofrequency < 15 MHz. (B) The enlarged single cell in the tissue. (C) The microscopic situation could be modeled by the shown electric circuit. (D) Usually we must consider a parallel capacitive factor in the impedance of ECM, due to the high concentration of non-ionized molecules in the microenvironment of the cells.

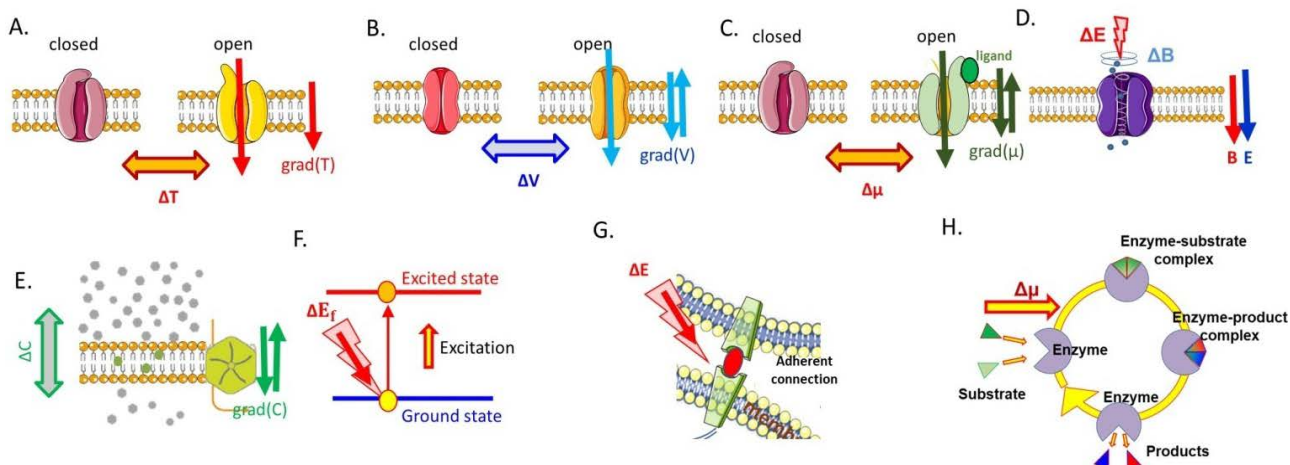

Figure 2. A few processes ignited by bioelectromagnetic interactions and their consequences. The transmembrane gradients of the temperature (T), potential (V), chemical potential (μ), and concentration of the ions, molecules, and other particles (C) are the driving forces in many the processes. They are combined in practice. The direction of the transmembrane gradients is mostly perpendicular on the membrane and may change by the direction of the external field and the given condition of the TME. (A) The thermally sensitive (temperature sensor as TRPV) channels are activated by temperature gradient. The gradient usually points from TME of the cells to its cytosol. (B) The voltage-gated channels are activated by the voltage gradient. (C) Ligand-gated channels are controlled by the fitting chemical potential of the reaction. (D) The ionic exchange may be through ion cyclotron resonance ignited by electric and magnetic fields pointing the cytosol from external excitation. (E) Diffusion processes ignited by the concentration gradient assisted by the electromagnetic charge separation. (F) Electron (atom & molecule) excitation by the electric field. (G) The adherent connections could be changed by the electric field. (H) Enzymatic processes are ignited by the gradient of the chemical potential assisted by the electric field.

field created by charge separation [17] (Figure 2(D)). The chemically controlled (ligand gated) channel senses the ligand bond which driven by the chemical potential (μ) of the reaction (Figure 2(E)). The quantum-mechanical processes by electric field excite electrons (in molecular bonds) [18] (Figure 2(F)). The electromagnetic field may modify (break or unite) the adherent connections [19] (Figure 2(G)). The electric field influences the enzymatic processes and may modify their outcome [20] (Figure 2(H)). The electric structure of the cells is principally involved in the chemical reactions and their absorbed energy acts selectively through different gradients. This active channelling controls the membrane potential and has critical role in all life processes.

The membrane potential may control the permeability of the ion channels between extra and intracellular electrolytes (Figure 3(A)). Nevertheless, this ion-selective rectification has two directions, depending on the sign of the ionic charge. The membrane furthermore rectifies the external signals, working like a gate controlled field-effect (FET) transistor gaining the signal amplitude (Figure 3(B)) with two basic processes:

- Normal rectification by the highly polarized cell-membrane, [21] [22] [23].
- Stochastic resonance that makes the rectification, [24].

The applied electromagnetic fields could make structural reorganization [25] [26], and may influence the various kinds of transports. The electric field drives transport on proton-flow [27] and Na/K ion pump [28] and changes the messengers [29]. The transmembrane potential also could be changed by an external electric field. The Schwan equation of electric field effect on the transmembrane potential [30] based on dispersion relation does not contain temperature. Only the field acts. Its validity is experimentally proven [31]. The static picture could be modified by the correlation between the amplitude of plasma-membrane

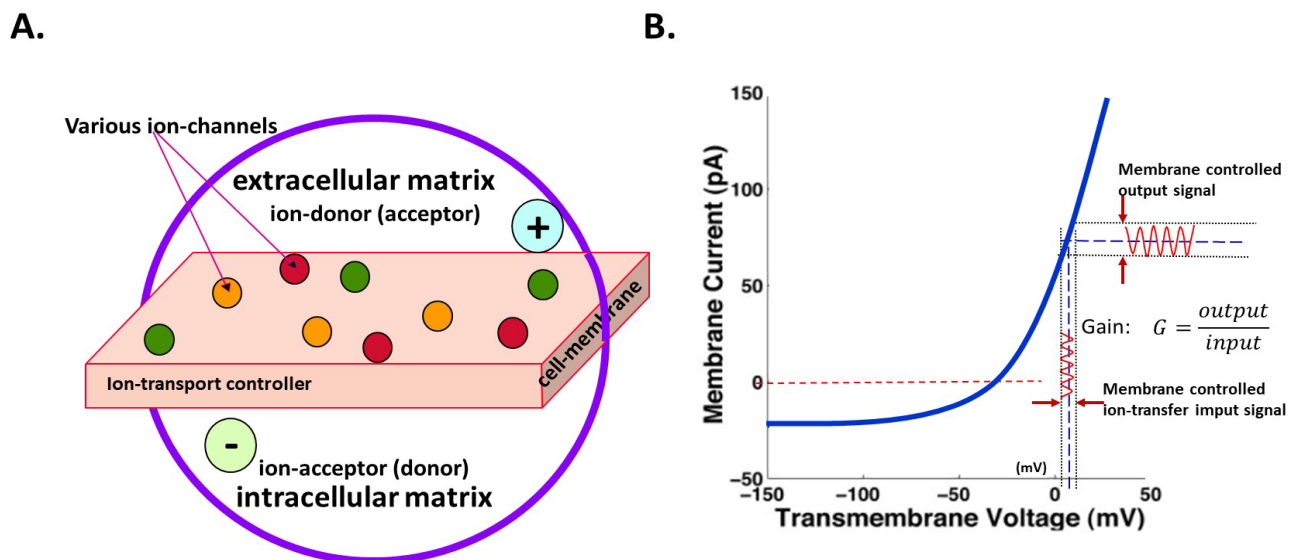

Figure 3. The membrane controls the ion flow between the electrolytes. (A) The direction of the flow depends on the charge and concentration of the species going through, changing the donor-acceptor situation by conditions. (B) The non-linear membrane current can gain the incoming signal.

fluctuation (fluctuates the C_m) and the applied electromagnetic effects [32].

Cancer cells have numerous challenges in a competitive, individual “fight” for their high energy demand. Cancer cells developed numerous tools to improve their adaptability in stressful environments. Cancer cells adapt and evolve in stressful conditions. As the disease progresses, cancer cells can undergo various adaptations that allow them to survive, proliferate, and evade the body’s immune system and anticancer treatments.

Adaptability is a complex process influenced by various factors, including genetic mutations, microenvironmental conditions, immune responses, and therapeutic interventions. The tumor microenvironment (TME) is the complex cellular and non-cellular environment surrounding a tumor, which consists of various leucocytes, chemical components, soluble factors of the extracellular matrix (ECM), and signaling molecules and vehicles. The increased metabolism of cancer cells profoundly changes the distribution of the electric charge in TME, also associated with a decrease in the cell membrane potential of the cancer cells. TME consists of various cellular and non-cellular components surrounding a tumor. The TME plays a decisional role in many functions of the tumor cells, including their adaptability to environmental stresses [33]. The key mechanisms by which cancer cells adapt are:

- The genetic mutations, which can occur spontaneously or be induced by external factors, enabling them to acquire new characteristics that promote their survival and growth.
- Phenotypic plasticity, which means they can change their characteristics in response to environmental cues. This plasticity allows them to adapt to different microenvironments.
- Epithelial-mesenchymal and opposite transitions allow the cancer cells to invade nearby tissues or metastasize to distant places in the body.
- Develop resistance to anticancer therapies through various mechanisms.

The adaptability of cancer cells poses significant challenges in the treatment of cancer and highlights the importance of developing new therapeutic strategies to overcome resistance and improve patient outcomes. TME has an essential role in the adaptation mechanisms of the tumor-cells.

Due to the TME specialties and the intensive proliferation, tumors have unique electromagnetic properties and due to the permanent proliferation require more energy than healthy cells. Cancerous tissue relies on glycolytic (fermentative) ATP production, while healthy cells use the Krebs cycle phosphorylation in mitochondria. Although the fermentative process delivers 18 times less ATP [34], glycolysis is simpler and more intensive to supply cells with ATPs than the Krebs cycle does. The simplicity of glycolysis favors the massive ATP demand of malignant cells. Transport processes, such as glucose, sodium, pyruvate, lactate, and hydrogen ion transporters, are crucial for energy production and are simpler in the case of glycolytic procedures. The cancer cells act autonomously, competing for energy sources with the neighboring cells, they do not cooperate, but all together the individual actions makes the tumor like a cooperative organ [35] [36].

Warburg defined the metabolic deviation of malignant cells, originated from mitochondrial dysfunction [37] [38] [39] or at least the mitochondria are not able to produce enough ATPs in time for cancerous proliferation. The high glucose influx of most cancers appears in the composition of the TME and the whole extracellular environment, allowing to distinguish the malignant cells from normal. The positron emission tomography, (PET) [40] detects the metabolic difference.

The transport processes are also crucial in glycolysis: the function of the glucose, sodium, pyruvate, and lactate, as well as the hydrogen ion transporters, must serve in time the actual energy-production processes. These forms of transport are also simpler in the glycolytic case than in the mitochondrial routes. Note, the situation is comparable to the well-known change of glucose metabolism in the sport-medicine when the muscles are overloaded, and the oxygen is not enough to supply the ATP demand by mitochondria.

The ionic and molecular concentration of the ECM changes robustly by the highly concentrated metabolites and waste of the processes. The increased electrolyte volume in the tumor [41] additionally improves the higher conductivity, and so the selection of the malignancy, which may increase the enhancing conductivity with the necrosis. Furthermore, the growing glucose concentration keeps the real but lowers the imaginary part of complex permittivity. Considering a healthy concentration of glucose 100 mg/dL, and the tumor tissue has double of that, the conductivity decrease is less than 10% [42]. According to (3), the decrease of conductivity with constant permittivity is also $< 10\%$.

The reprogrammed metabolic process is a strong dysregulation of the electrolyte balance in malignant volume [43]. The composition change, the high ion concentration, is measurable by the electric conduction of the various electrolytes, directing the electric current to the more conductive path (Figure 4). This process clearly selects between the cells of different metabolic forms and automatically focuses the RF-current on the close TME electrolyte of malignant cells. In time-domain spectroscopy of breast tumor tissues of patients also shows the much larger conductivity of tumors than normal tissue [44] [45] [46] [47] [48]

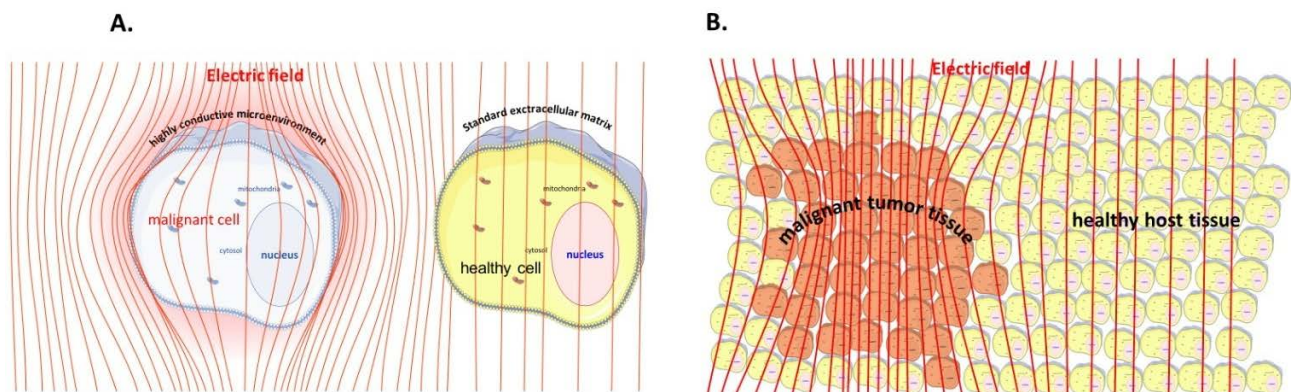

Figure 4. The conductivity selection. (A) The high electric conductivity of TME focuses the RF-current on the tumor cells (micro selection). (B) The overall higher conductivity of ECM in tumor mass concentrates the current to the cancer lesion.

and liver tumors [49] [50]. The *in vivo* measurement of SMT-2A tumors in rats shows a significant difference (<6 times) in the conductivity of tumorous and normal tissues [51].

This irregular behavior of electric conduction can be imaged by Electric Impedance Tomography (EIT), [52] [53]. Also, this effect could be applied in prophylactics like mammography [54] [55] too. Another impedance method, the MRI Electrical Impedance Tomography (MREIT) also clearly shows the conductance selection of tumors in theoretical description and *in vivo* [56]. The increase of the current density in the tumor could be visualized by the measurements of real processes by radiofrequency current density image (RF-CDI) [57] [58] [59] [60].

The high conductivity also characterizes the intracellular electrolytes of malignant cells [61], growing by the progression rate of malignancy [62]. The intracellular networks of the cytoskeleton and the collective excitation (soliton [63]) of microtubules increase intracellular conductivity. The progression increases the TME and Tumor EMC conductivity too, so the precision of the selection by conduction differences grows by the development of malignancy.

The living matter exists in an aqueous solution, which is partly ordered, [10] [64]. The ordered electrolyte states were suggested as much as 50% of the total amount of the aqueous solution in membrane living systems [65]. The membrane potential forms the dominant electrolyte order [66] [67] in its near vicinity. Carcinogenesis has drastic changes in the membrane of the cell uncoupling it from the neighbors, and producing membrane defects and numerous outside unconnected transmembrane proteins and their clusters (rafts). This process induces a rearranging (disordering) of the electrolyte structure which utilizes energy [68], similar, to the melting of ice with latent heat. This drastic change (phase transition) modifies the actual physical properties (like the dielectric constant) of the material without changing the composition of the medium itself. The TME alternates the electron/proton homeostasis increases the pH intracellularly and decreases it in the TME [69]. The cell membrane of the malignant cells is lowered compared to the healthy equivalents [70], and together with the lower pH of the TME the membrane thickness grows the inner side of the bilayer considerably changes, and the mixture of the lipid molecules replaced by the dominant phosphatidylcholine [71]. Decrease of the membrane potential in malignant cells disorients a part of the ordered electrolyte [72] [73] [74], which increases the electric permeability, [75], and decreases the cell-cell adhesion, [76]. The order-disorder phase-transition indicates the development of the disordered autonomy (α -state) and the disappearance of the collective networking (β -state), [77]. The significantly larger permittivity in tumor tissue *in vitro* is explained on this basis, [78]. The ordered structure makes it possible to “channel” the energy flow in the direction of the polarization order, while the outside electric field can spin the disordered polar molecules, whose movements absorb the energy functioning like “friction” in the medium. In this way, the high dielectric constant

allows the additional selection by its higher energy absorption from the optimally applied RF energy.

The malignancy increases both the conductivity and dielectric permittivity (capacity) of the membrane of cancer cells [62], which promotes higher selectivity in severe malignant cases. The specific capacitance of the membrane and the cytoplasmic conductivity grows with increasing malignancy supports the focusing process in severe malignant cases [62].

The actual dielectric properties are also distinguishable by the water content of the malignant tissue, which is higher than that of their healthy counterparts. The proliferating cells control their cell volume by their water content, in the malignant growth [79], and by making more biophysical distinctions for properly applied electromagnetic treatment. The developing malignancy of the cancer cells of the mouse ovarian surface epithelial cell line increases the cytoplasmic and membrane electric permittivity with swelling in a low degree of malignancy [62].

The conductivity and relative permittivity do not considerably change by time and temperature in the MHz region for healthy ex-vivo muscle samples [80], so we also expect a relatively small variation of the other tissues ex-vivo. However, *in vivo* the change is considerable [44] [45] [46] [47] [49] [50] [51] [55], the transporting electrolytes (mainly the blood perfusion) change of the electric parameters by time and temperature. These processes are dominantly physiologically regulated, so homeostatic control has substantial importance in the changing electromagnetic properties [81]. The higher dielectric permittivity of the tumor cells and mass gives an additional selection factor [82] to the higher conductivity discussed above. The missing bonds and disordered TME definitely changes the electric behavior of the malignancy [83]. The RF current can recognize the altered structure [75] [78], useful in practice [52] [54].

The membranes may have phase transitions, causing restructuralization of the lipid layers. The temperature may cause a chain melting transition which increases the membrane fluctuations and the dielectric permeability near the transition temperature [84]. The penetration of the membrane also rises near transition temperature increasing the likelihood of spontaneous lipid pore formation [84].

The chemical and electric gradients promote ligand connections and receptor activity, respectively. These processes may cause chemo- and electro-taxis [85], which promotes the drift movement of the cells, and could have a role in invasion of the malignancy.

The electrolytes, which are charge neutral on the two opposite sides of the membrane lipid layers have a diffusion driving force due to different concentrations of the ions in the electrolyte. However, the diffusion of charged ions changes the charge distribution in both electrolytes, which affects the membrane. An ion present in a higher concentration on one side of the membrane crosses the membrane as a result of the diffusion driven by the concentration gradient. This

process creates an electric field by the carried charge of the ion opposing the driving force of diffusion. The ion-selecting process actively moves both anions and cations gaining the electric field between the two sides of the membrane. In the same time the membrane is not permeable for some ions and large units. The exchange of ionic species on this cannot form electric or diffusion equilibrium alone. The penetration processes last until the concentration gradients and the electric field are balanced, forming the observed membrane potential. The Goldman-Hodgkin-Katz equations modeled the electro-diffusion process [86], with conditions:

- A constant concentration difference between outer and inner side of the membrane \Rightarrow constant transport rate through membrane.
- Migration of ions through membrane \Rightarrow electric bilayer on both sides of the membrane.
- All kinds of ions on both sides of the membrane are considered simultaneously.
- Membrane is neither fully permeable nor fully non-permeable for any ion.
- Different ions have different permeability.

The ionic exchange processes which create the membrane potential fluctuate adding a noise to the resting potential which is in fact an average of the actual potentials. Ion channels, which are responsible for the movement of ions across the cell membrane, can exhibit stochastic behaviour. The opening and closing of ion channels can introduce variability in the resting potential. A single ion or its groups driven by concentration gradient may be overloaded and create electric contra force against the diffusion restores the balance. The same thing happens when the electric field prevails against the diffusion. It works like a promoter-suppressor pair which precisely tunes the necessary value defined by the given conditions [87] [88]. The potential oscillations dramatically improve action potential precision [89].

While bioelectromagnetic fields may potentially interact with cancer cells, it is currently challenging to draw definitive conclusions about their impact on cancer cell adaptability. Our present objective is to describe the charge distribution/redistribution in malignant tissues with the aim of understanding one of the electrodynamic aspects of the high adaptability of malignant cells. We give a proposal on how to decrease the detrimental effect of charge distribution in tumors.

2. Methods

The biological material is imperfect dielectrics, having displacement current and conductive current as well. Two parameters are used to characterize tissues from an electric point of view: conductivity (σ) and dielectric permittivity (ϵ). These physical properties could be used in diagnosis [90] and in treatments [91]. The current density (j) induced by E field vector and ρ charge density:

$$\operatorname{div}E = \rho, \quad j = \sigma E,$$

and the charge conservation.

$$\frac{\partial \rho}{\partial t} + \operatorname{div} \mathbf{j} = 0$$

Having f frequency in harmonic signal the \mathbf{j} became complex ($i = \sqrt{-1}$):

$$\mathbf{j} = (i\omega\varepsilon + \sigma)\mathbf{E} \quad (1)$$

where $\omega = 2\pi f$ is the circular frequency. When there is no free charge density ($\rho_f = 0$):

$$\operatorname{div}(i\omega\varepsilon + \sigma)\mathbf{E} = \operatorname{div}(\sigma^*\mathbf{E}) = \rho \quad (2)$$

The superscript * denotes the complex numbers:

$$\sigma^* = \sigma + i\omega\varepsilon \quad \varepsilon^* = \varepsilon - i\frac{\sigma}{\omega} \quad (3)$$

Hence:

$$\begin{aligned} \operatorname{grad} \varepsilon \cdot \mathbf{E} + \varepsilon \cdot \operatorname{div} \mathbf{E} &= \rho \\ \operatorname{grad} \sigma^* \cdot \mathbf{E} + \sigma^* \cdot \operatorname{div} \mathbf{E} &= 0 \end{aligned} \quad (4)$$

where ρ charge density appears only by the polarization (space-charge). With further simplification of (4), we get:

$$\left[\operatorname{grad}(\varepsilon) + \operatorname{grad}(\ln \sigma^*) \right] \cdot \mathbf{E} = \rho \quad (5)$$

The gradient of permittivity determines the behavior, which linearly depends on the \mathbf{E} field. The logarithm of the conductivity smooths its changes, having only a minor effect. The (5) has no structural components but the parameters (ε and σ) are frequency dependent.

According to (5) the inhomogeneous dielectric material of the living tissues, and their higher organizations, the permittivity gradient creates space charge. The accumulated space charge increases capacity with frequency dependence, without structural modification.

The simplest arrangement to show interfacial polarization is a condenser with two layers of permittivity between its electrodes. The dielectric heterogeneity is a cube having two different materials, representing the inhomogeneity of the material with d_1 and d_2 thickness, placed in a serial arrangement in the condenser. The space charge will be created at the boundaries of the permittivity blocks, which are parallel to the electrodes (**Figure 5**).

We define the conductivity of this composite dielectric block by:

$$\frac{d_1 + d_2}{\sigma^*} = Z = \frac{d_1}{\sigma_1^*} + \frac{d_2}{\sigma_2^*} \quad (6)$$

From this definition, we receive the independent geometry conductivity and complex permittivity depending only on the ratio of volumes:

$$\varepsilon^* = \frac{\sigma^*}{j\omega} = \frac{\sigma_1^* \sigma_2^*}{i\omega \left[a(\sigma_2^* - \sigma_1^*) + \sigma_1^* \right]} \quad (7)$$

where $a = \frac{d_1}{d_1 + d_2}$ represents the geometry. The solution depends just on the

layer thicknesses. The parallel blocks are irrelevant, because the gradient and the field are perpendiculars, and their scalar product is zero.

The dielectric permittivity depends on the frequency, causing dispersion. The simple theory of dispersion was laid out by Debye [92]. According to Debye theory the complex dielectric material has a breaking-point circular frequency ($\omega_c = 2\pi f_c$), characterizing the transition between the two states, and the relaxation time (τ) is $\tau = 1/\omega_c$. The physical meaning of this relaxation time is the time during the displacement vector oriented by the switched-on unit electric field. The complex dielectric material has different permittivity at high frequencies (ϵ_∞), and at low frequencies (ϵ_s) (Figure 6), and according to Debye considerations:

$$\epsilon^*(\omega) = \epsilon_\infty + \frac{\epsilon_s - \epsilon_\infty}{1 + i\omega\tau} + \frac{\sigma_s}{i\omega} \quad (8)$$

Considering the heterogeneity form Figure 5. We obtain:

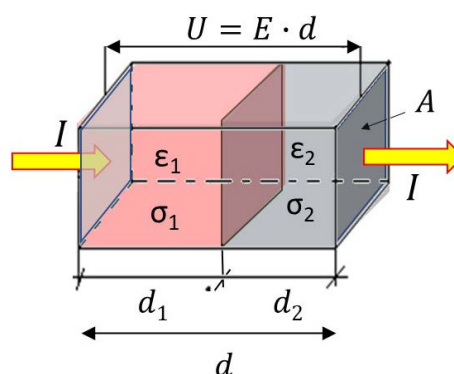

Figure 5. Arrangement of two dielectric materials in a condenser. U is the potential, d the length and A the cross section of the block, which has I current through.

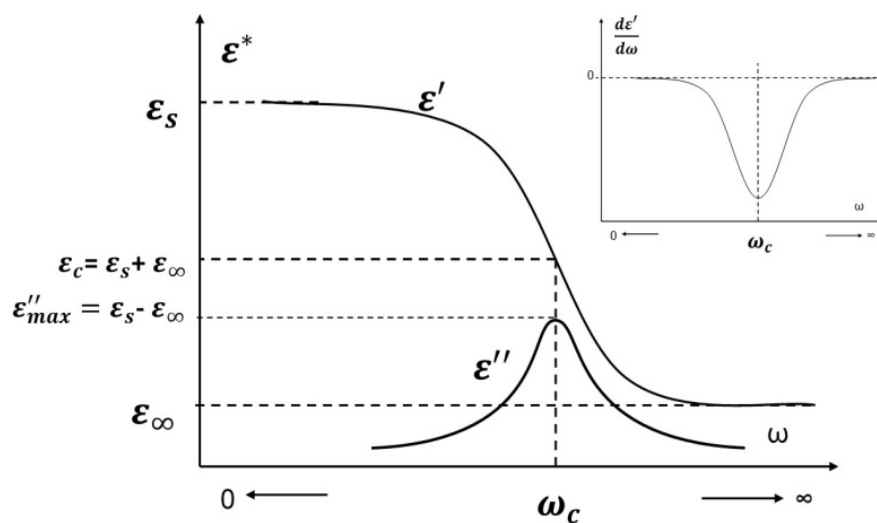

Figure 6. The complex dielectric permittivity ($\epsilon^*(\omega)$) in Debye scheme. The derivative of the real part ($\frac{d\epsilon'}{d\omega}$) has a minimum in ω_c . It is shown in the insert.

$$\begin{aligned} \epsilon^* &= \frac{\epsilon_1 \epsilon_2}{a(\epsilon_2 - \epsilon_1) + \epsilon_1} + \frac{1}{i\omega} \cdot \frac{\sigma_1 \sigma_2}{a(\sigma_2 - \sigma_1) + \sigma_1} + \frac{\mathfrak{E}}{1 + i\omega\tau} \\ \epsilon_\infty &= \frac{\epsilon_1 \epsilon_2}{a(\epsilon_2 - \epsilon_1) + \epsilon_1} \\ \epsilon_s &= \epsilon_\infty + \mathfrak{E} \\ \mathfrak{E} &= \frac{(\sigma_1 \epsilon_2 - \sigma_2 \epsilon_1)^2 a(1-a)}{[a(\epsilon_2 - \epsilon_1) + \epsilon_1][a(\sigma_2 - \sigma_1) + \sigma_1]^2} \\ \tau &= \frac{a(\epsilon_2 - \epsilon_1) + \epsilon_1}{a(\sigma_2 - \sigma_1) + \sigma_1} \end{aligned} \tag{9}$$

This result is remarkable: the inhomogeneous dielectric arrangement could have larger dielectric permittivity than the individual components. The permittivity, in this case, is a complex value, which is frequency-dependent and can be approximated by the Debye principles. The complex dielectric material has different permittivity at high frequencies (ϵ_∞), and at low frequencies (ϵ_s). Note that when the gradients of permittivity and conductivity are perpendicular on the penetrated external field, space-charge is not formed. The parallel blocks are two independent imperfect condensers, calculated as a parallel circuit of two condensers.

The overall frequency-dependent conductivity (σ_Σ) of a unit cube ($d = 1, A = 1$) of the tissue is shown with discrete electric elements on **Figure 1(B)**, is:

$$\sigma_\Sigma = \frac{R_1 + R_C + R_2}{R_1(R_C + R_2)} = \frac{1}{\sigma_1} + \frac{1}{\frac{1}{i\omega\epsilon} + \sigma_2} \tag{10}$$

The high and low-frequency current differently depend on the frequency (**Figure 7(A)**) slope of σ_Σ , and have changed in $f = 10 - 100$ MHz, (**Figure 7(B)**) at the range of β/δ frequency dispersion identified by Schwan and colleagues, [93] [94],

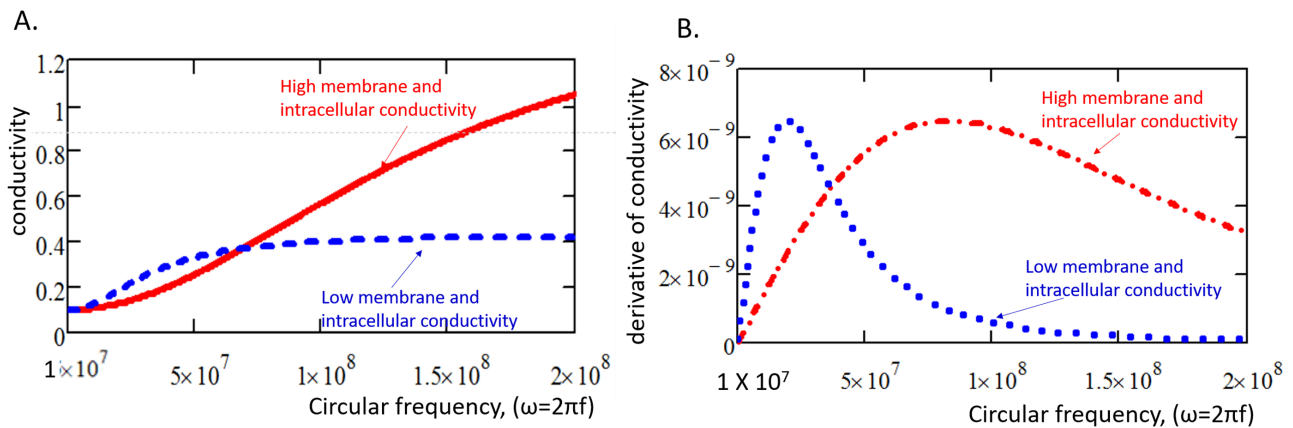

Figure 7. The conductivity vs. circular frequency $\omega = 2\pi f$ of a unit cube of the tissue at the low ($\sigma_2 = \frac{1}{3}$ S/m) and high ($\sigma_2 = 1$ S/m) membrane and intracellular resistivity, ($C = 10^{-8}$ F; $\sigma_1 = 0.1$ S/m). (A) The conductivity; (B) The derivative (slope) of the conductivity function. The numeration of conductivity corresponds to **Figure 1(B)**.

The charge distribution, forming considerable space charge within the TME (**Figure 8**) can arise from several factors:

- **Charge:** Cells within the TME, including cancer cells and immune cells, possess an overall net charge due to the presence of charged molecules, such as proteins and nucleic acids. The charge on the cell membrane arises from the distribution of charged phospholipids and membrane proteins. These effects can lead to imbalances in ion concentrations within the TME. The increased metabolism of cancer cells profoundly changes the distribution of the electric charge. The change is principally associated with a decrease in the cell membrane potential of the cancer cells and an increase in the charge of the TME. The TME can exhibit altered electrical conductivity due to changes in ion concentrations and the presence of charged molecules. These conductivity variations can affect the distribution of electric fields and influence electrodiffusion.
- **Extracellular Matrix:** The ECM, which provides structural and electrolyte support to tissues, is composed of a complex network of proteins, proteoglycans, and glycosaminoglycans. Proteoglycans and glycosaminoglycans have negatively charged sulfate and carboxyl groups, contributing to the overall charge distribution within the ECM. Alterations in the ECM composition and stiffness [95] can affect the diffusion properties of ions in the TME.
- **Soluble Factors:** Soluble factors present in the TME, such as cytokines, growth factors, and chemokines, can also possess charged regions. These factors can be secreted by various cells within the TME and may interact with cells or components through electrostatic interactions.
- It's important to note that the charge distribution within the TME is a dynamic and complex system, influenced by various cellular and molecular interactions. The overall charge distribution can impact cellular behaviors, signaling pathways, and interactions between cells and the ECM. Understanding the charge distribution within the TME is a part of the broader study of the tumor microenvironment, which is crucial for unraveling the mechanisms of tumor growth, invasion, and metastasis.

The membrane potential (φ_m) is usually 30% smaller in cancer cells than the normal ones [96], however its TME is richer in ionic and inert molecular species. The high proliferation rate, the high intracellular Na^+ concentration and changes on the transmembrane proteins lower φ_m , which may induce the Ca^{2+} efflux. The reduced membrane potential makes the cell outside relatively negative compared to the constant outside positive membrane potential of healthy cells. The difference rearranges the charge distribution between healthy and tumor cells, and as a result of active cancer proliferation, the charge distribution changes over time. The charge redistribution makes strong heterogeneity in the electrical conductivity for transmitted RF current and so the electrical resistance depends on the charge distribution.

A depolarized membrane is considered a driving force for the intracellular

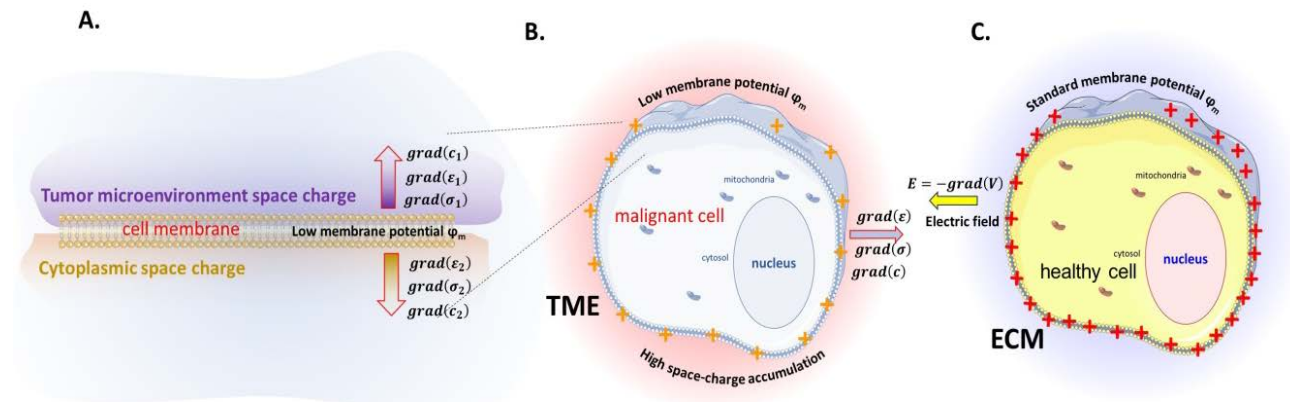

Figure 8. The cell membrane polarization is outside positive in resting case. The directions of the concentration (c), dielectric permittivity (ϵ) and conductivity (σ) gradients are perpendicular on the membrane. (A) A part of the cell-membrane of malignant cell with its environment. (B) The malignant cell has low membrane potential. (C) The healthy cell has normal membrane potential, and an E-field appears to the direction of lower potential of malignant cells.

increase of Ca^{2+} which is partly a bioelectronic cancer regulator that affects proliferation, migration, invasion and metastasis of cancer cells. Furthermore, changes in φ_m are related to the modulation of local concentrations of signaling molecules and ions, the spatiotemporal regulation of morphogenesis, the interaction with heterogeneous networks (that combines conventional gene regulatory network) is controlled by spatiotemporal bioelectrical patterns based on electric potentials and currents from steady and oscillatory multicellular states, among others. In turn, these spatiotemporal bioelectrical patterns influence on the spatiotemporal distributions of signaling ions and molecules that modulate biochemical pathways in cancer cells, and therefore in growth and regeneration.

Several studies have investigated the potential impact of electromagnetic fields on cancer cells and their proliferation [97]. A special electromagnetic oncotherapy combines the thermal and nonthermal effects to improve the efficacy of the electromagnetic effects [98] [99]. This method uses the modulated electric field impact to space-charge and promotes the Ca^{2+} influx to the cancer cells [100], blocks the tumor-supporting injury current [101] and reestablishes the E-cadherin + β -catenin intercellular adherent connections to repair the lost collectivity of the cells [102]. The method uses a strong synergy between the thermal and nonthermal effects [103], using the thermal component as an environmental factor gaining the chemical reaction rate [91]. The specific mechanisms underlying any potential effects of bioelectromagnetic treatments on cancer cell adaptability presently are not well-established [104]. The ionic structure and density of ions differ in the microenvironment of cells from the average ECM.

The Nernst-Planck equation is used to describe the flux of ions due to diffusion and electrostatic forces. It considers the concentration gradient, the electrical potential gradient, and the ion mobility [105]. The Nernst-Planck equation describes electrodiffusion, refers to the combined effect of diffusion under influence of electrical forces. This movement rearranges the charges in the medium, and forms heterogenic distribution developing internal electric fields in-

duced by the various space charges. These fields interact even in the relative large distances. A local arrangement of the charges embedded in the material structure (in electric meaning impedances in the electric fields) is regarded as a “cell” in the complex structure. These cells overlap and interact in a fractal-like behavior. The Nernst-Planck type space charge [106] can be formed in every non-perfect dielectric material, including the biological tissues. The basic process is driven by the complex interaction of the diffusion and electromagnetic charge transfer. The driving force of the diffusion is the concentration gradient, while the charge-transport made by electric field. In aqueous solutions like the electrolytes in the living objects, ions represent the charges interaction with the electric field. The electrodiffusion in the TME is important as it can impact various tumor-related processes. In the context of tumor development, electrodiffusion can have several influences.

- **Tumor Microenvironment:** Electrodiffusion can affect the composition and properties of the tumor microenvironment. The electrical gradients within tissues can influence the distribution and movement of ions, nutrients, and signaling molecules. Alterations in the ionic concentrations and pH due to electrodiffusion can create a microenvironment that supports tumor growth and survival.
- **Cell Proliferation and Migration:** Electrical gradients and ion movements can affect the behavior of cells within a tumor. Studies have shown that electric fields can influence cell proliferation, migration, and invasion. Certain ion channels and transporters play crucial roles in these processes, and their dysregulation can contribute to tumor progression.
- **Angiogenesis:** Electrodiffusion can also impact angiogenesis, the process of new blood vessel formation. Electrical signals can guide endothelial cells, which line the blood vessels, and influence their migration and organization. Electrodiffusion-mediated changes in ion concentrations and pH can modulate the expression of angiogenic factors, thereby affecting the formation of blood vessels within tumors.
- **Drug Delivery:** Electrodiffusion can influence the delivery and distribution of drugs within tumors. The presence of electrical gradients can affect the transport of charged molecules, such as chemotherapeutic agents, into tumor tissues. This can impact the efficacy of treatments and contribute to drug resistance.
- **Electric Field-Based Therapies:** In recent years, electric field-based therapies, such as electroporation and electrochemotherapy, have emerged as potential treatment modalities for cancer. These therapies utilize externally applied electric fields to enhance drug delivery or induce cell death. The principles behind these therapies rely on the effects of electrodiffusion on tumor cells and their microenvironment.

Studying electrodiffusion in the TME can help uncover potential targets for therapeutic interventions aimed at modulating ion concentrations and restoring normal electrochemical gradients within the TME. It's important to note that the

influence of electrodiffusion on tumor development is a complex phenomenon, and the specific effects can vary depending on tumor type, location, and other factors. Ongoing research in this field aims to further elucidate the underlying mechanisms and explore potential therapeutic applications.

The ionic electric conductions naturally carry chemical mass transport too, synergizing the electric conduction and the diffusion- and drift-like material transport as well. According to Fick's Law, the diffusive current density is:

$$j_{diff} = -D \frac{dC(x)}{dx}, \quad (11)$$

where D is the diffusion constant of the given chemical component and the ionic chemical component at x has a concentration $C(x)$. Denote the ionizing level of the given chemical component by Z , and its ion mobility by β . Then at the applied E field-strength, the drift velocity is:

$$v_{drift} = -\beta E. \quad (12)$$

which (using the Einstein relation) could also be written in the form:

$$v_{drift} = -\beta e E = -\frac{D}{kT} Ze E \quad (13)$$

where e is the elementary charge (electron charge), k is the Boltzmann constant, and T is the tissue temperature and Z is the valence of the moving charge particle. Hence, the drift-current density in the transition layer is:

$$j_{drift} = -C(x) \frac{D}{kT} Ze E \quad (14)$$

Therefore, the particle current density of the chemical component is:

$$j = -D \frac{dC(x)}{dx} - C(x) \frac{D}{kT} Ze E \quad (15)$$

From this the jointly transported electric current density is:

$$j_e = Ze j = -Ze D \frac{dC(x)}{dx} - C(x) \frac{D}{kT} Z^2 e^2 E \quad (16)$$

which looks in Ohm's Law-form like:

$$\begin{aligned} j_e &= \sigma (E + E^{(i)}), \\ \sigma &= C(x) \frac{D}{kT} Z^2 e^2 \\ E^{(i)} &= -\frac{Ze D}{\sigma} \frac{dC(x)}{dx} \end{aligned} \quad (17)$$

where $E^{(i)}$ is the field created by charge density. For numerical investigation we normalize these values:

$$j = \frac{j_e}{\frac{Ze D C_2}{\delta}} = \frac{\frac{C_1}{C_2} e^{-\frac{Ze U}{kT}} - 1}{e^{-\frac{Ze U}{kT}} - 1} \frac{Ze U}{kT} = \frac{Q e^{-\theta} - 1}{e^{-\theta} - 1} \theta \quad (18)$$

where C_1 and C_2 are the concentrations of the interface layer incident and emergent sides, and δ is the thickness of the transition layer by U potential-drop on it; the $\theta = \frac{ZeU}{kT}$ and the $Q = \frac{C_1}{C_2}$ is the concentration ratio. This result shows that the “foreign” field strength appears only where the particle concentration has a gradient (e.g. in the phase boundaries).

Suppose a linear change of the potential in the transient layer; from (18) we get:

$$j_e = \left(\frac{Z^2 e^2 D}{kT \delta} \right) \frac{C_1 e^{-\theta} - C_2}{e^{-\theta} - 1} U \quad (19)$$

The tissue boundaries are inhomogeneous interfaces, where external field strengths $E^{(ex)}$ may be a perturbative addition to (17), causing a charge redistribution. The charge conservation at the perturbation:

$$\begin{aligned} \frac{\partial \rho}{\partial t} &= -\frac{\sigma}{\varepsilon} \rho - \sigma \frac{\partial E^{(ex)}}{\partial x} = -\frac{\sigma}{\varepsilon} (\rho - \rho^{(s)}), \\ \rho^{(i)} &= \varepsilon \frac{\partial E^{(ex)}}{\partial x} \end{aligned} \quad (20)$$

Its solution is:

$$\rho = \rho^{(s)} + \rho_0 e^{-\frac{t}{\tau}} \quad (21)$$

The perturbation exponentially decays in (21), but space charge $\rho^{(s)}$ remains due to the inhomogeneity. The time constant differs from the previous one, and it is the same order of magnitude as the periodic time of the external signal.

The charge of the i^{th} and k^{th} condensers in the interface is:

$$\begin{aligned} Q_i &= -C_i U_i = -C_i R_i I_{iR} = -\tau_i I_{iR} \\ Q_k &= C_k U_k = C_k R_k I_{kR} = \tau_k I_{kR} \end{aligned} \quad (22)$$

where U_i, U_k are the potentials, I_{iR}, I_{kR} the resistivity dependent currents in the condensers, $\tau_i = C_i R_i$ and $\tau_k = C_k R_k$ are the time constances of the given circuits. Moreover, the resultant surface charge:

$$q_{i,k} = \frac{Q_k + Q_i}{A} = \tau_k j_{kR} - \tau_i j_{iR} \quad (23)$$

where A is the surface of the electrodes which provides the external field (*i.e.* a plate condenser model). The surface charges drastically differ in the case of networked healthy and autonomic cancer cells.

The current flow in the presence of external fields is well-known in conductors. We have shown above the polarization effect by external electric fields in imperfect conductors in the macro and micro range even in “porous” conditions like the cellular structure. This polarization differs from that that induces injury current when its stability is disturbed. Contrary to the internal polarization, the external triggering has no stable (current free) state, when the external field is time-varying (*i.e.* alternating). In the cases of electric currents, irrespective of the internal or external sources, the conductivity and the electric field-induced

processes by the polarized layers constructed by electrolytic diffusion has to be counted (Figure 9). These electric current are called bio-currents.

We use conditions in which time constants (τ_k and τ_i) are commensurable with the quarter of the periodic time. The electric circuit schematic of this model is shown in Figure 10. This model has Nernst-Planck characteristics, so we refer to it as a Nernst-Planck cell.

The interconnected cells produce a variant of the Nernst-Planck cells, having a heterogenic distribution of the space-charges (Figure 11).

3. Results

Due to the concentration variance of charges the conductivities differ, depending on the values of the potentials. The approximations of (19) at an external signal with U potential:

1) If $|U| \approx 0$ is a small value:

$$j_e \cong \frac{Z^2 e^2 DC_1 U}{kT\delta} \tag{24}$$

2) If $U \gg 0$ is a large positive potential, then from (19):

$$j_e = \frac{Z^2 e^2 DC_2 U}{kT\delta} \tag{25}$$

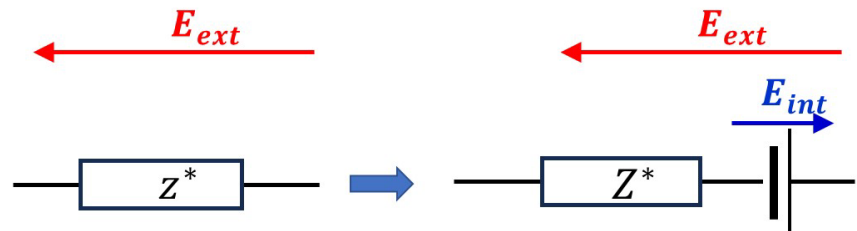

Figure 9. Model of the effect of the Nernst-Planck principle on a material having z^* impedance developing $Z^* + E_{int}$ by forming Nernst-Planck space charge. The non-perfect dielectric material develops an internal electric field by a double layer influenced by the external electric field. The newly formed electric field can be modelled by an additional opposite field caused by the internal rearrangement of charges.

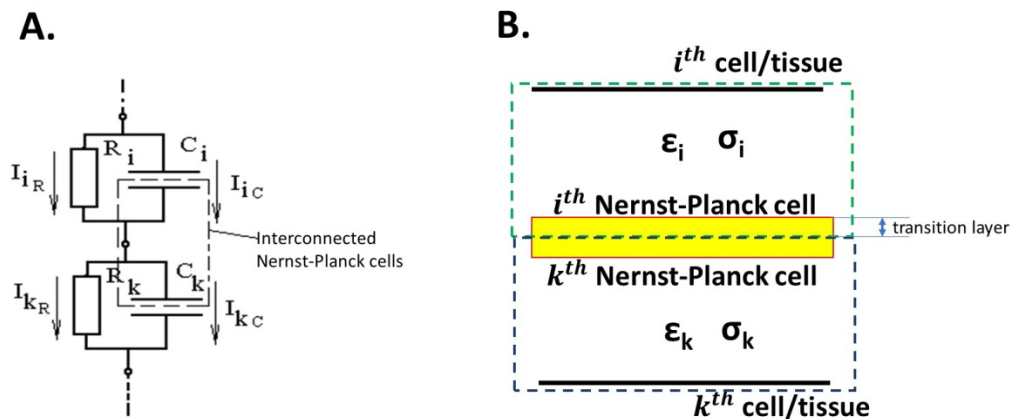

Figure 10. Transition layer schematic of the i^{th} Nernst-Planck cell of the corrected model.

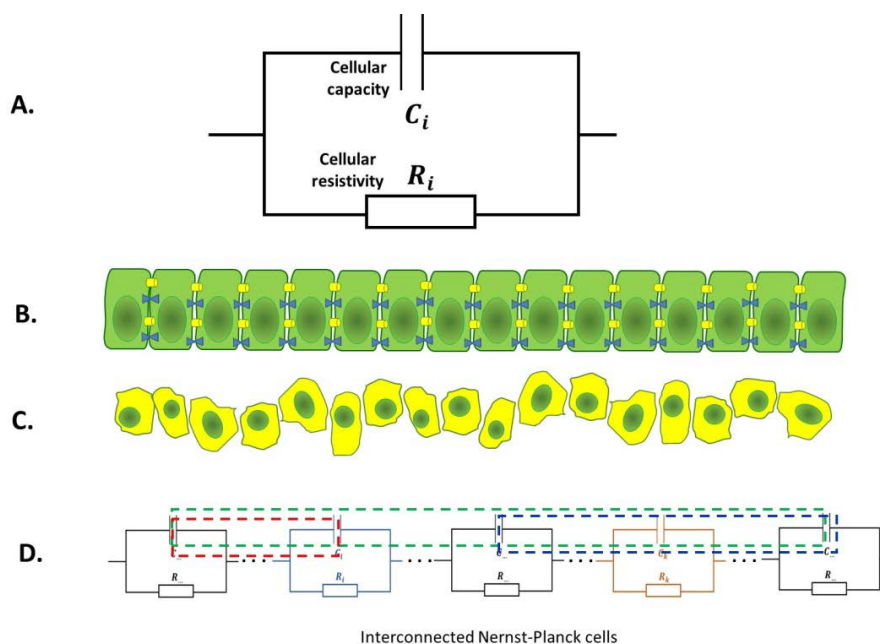

Figure 11. A schematic of space-charge model in serial connection shown in one dimension. (A) The cellular electric analogue of the i^{th} cell in the line. (B) A line of healthy cells, connected network. (C) Line of malignant cells. Broken connections, changed cellular morphology, seeking to more spherical shape. The space-charge between them essentially differs from the healthy situation. (D) The electric analogue of the cellular line. The transition layer for Nernst-Planck cell is shown between the two condenser components of the cells in the line. The dashed rectangles are examples of the formed Nernst-Planck cells. These are embedded, interacting with distant cells in long range, not only with the next neighbor.

3) If $U \ll 0$ is a large negative potential, then from (19):

$$j_e = \frac{Z^2 e^2 D C_1}{kT \delta} U \quad (26)$$

The results (24)-(26) apparently forms Ohm-law in extremes of the U potential having apparent conductivity $\sigma_a = \frac{Z^2 e^2 D}{kT} C_i$, where C_i is the concentration of given chemical component in the electrolyte. Due to the multi-ionic behavior (n components) of the TME the Ohm law has further generalization. When the k^{th} component has specific Z_k valence, D_k diffusion constant and C_k concentration, the generalized apparent conductivity would be.

$$\sigma_a^{(S)} = \sum_{k=0}^n \frac{Z_k^2 e^2 D_k}{kT} C_{i,k} \quad (27)$$

As a result, the Nernst-Planck cell is a potential dependent two-pole with non-linear characteristics, as its conductivity depends on the direction of the current. Hence, the cell rectifies and distorts (**Figure 12**), so, for example, the supplied sinusoidal potential will gain a non-sinusoidal current containing upper harmonics. It is vice versa valid: if we have over harmonics on a harmonic potential excitation. The harmonic alternating potential shows the rectification of the sig-

nal.

The frequency spectrum of the current density by Fourier transformation of the alternating potential is shown in **Figure 13**. The time-derivative of current density shows that the slope of the current development depends on the direction of the external field, making some-kind of hysteresis.

Practical clinical applications frequently use 13.56 MHz RF radiation, which frequency is reserved for medical and industrial applications. This RF shows a particularly good relative difference in the dielectric permittivity of normal and tumorous tissues. The imaginary part of the conductivity, which is proportional to the relative permittivity ($Im(\sigma^*) = \omega \cdot \epsilon$) is ~ 15 times higher in the tumor than in the connective and the adipose tissues in breast cancer (**Figure 14**). The same minimal complex resistance was obtained in two model calculations for ellipsoidal cells [107], so the selection at the 13.56 MHz frequency is optimal.

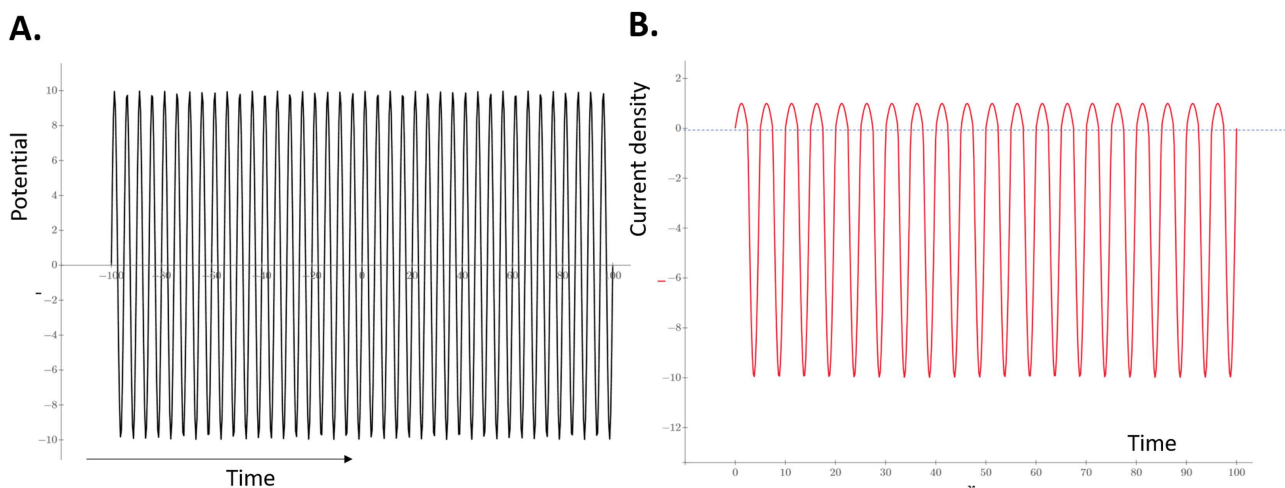

Figure 12. Nernst-Plank cell characteristics. (A) The harmonic external signal. (B) The current density having $C_1/C_2 = 10$. The rectification modifies the time-dependence.

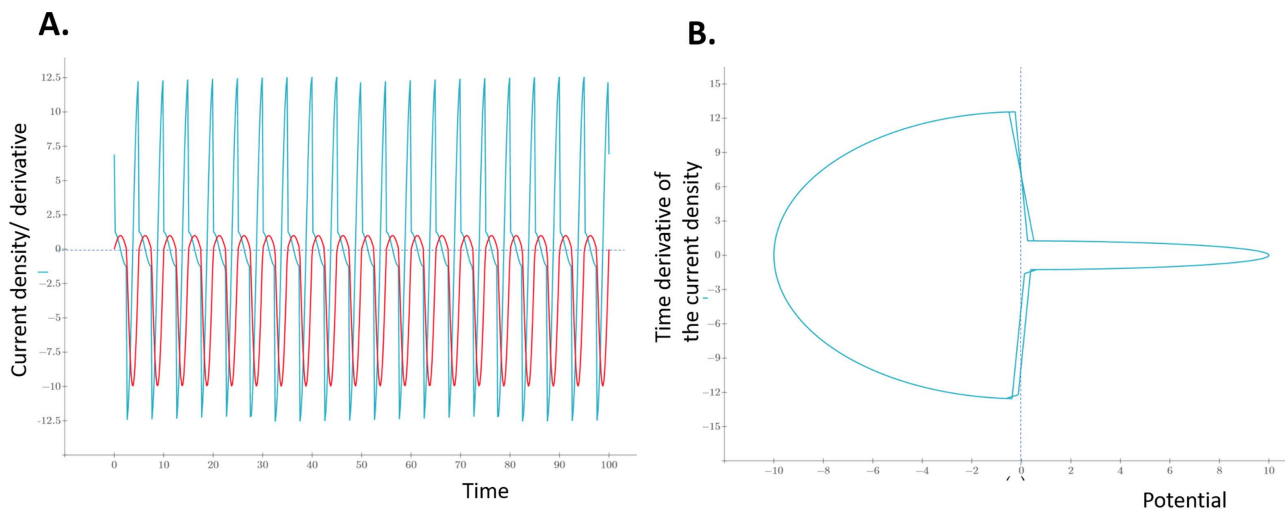

Figure 13. The time-derivative of the current density shows non-linear behavior. (A) The current density and its derivative. (B) The time derivative of current density has hysteresis by the changing potential.

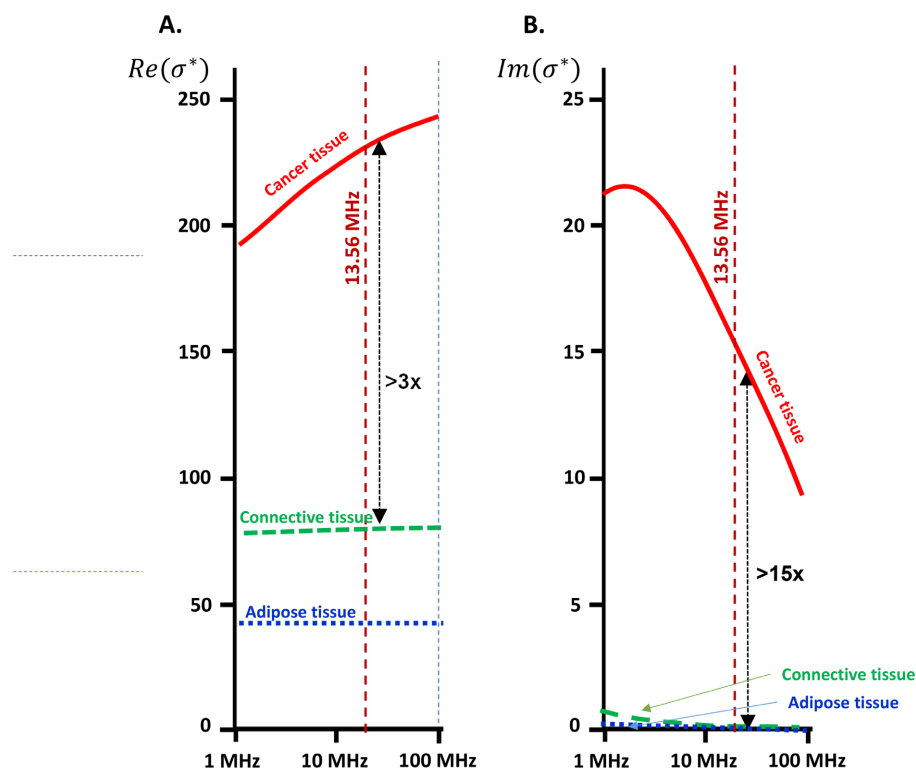

Figure 14. The electric parameters of breast tissues vs. frequency [55]. The 13.56 MHz shows high selectivity in both parts of the electric conductivity. (A) The real part; (B) The imaginary part ($\omega \cdot \varepsilon$) of the conductivity.

The selective energy-absorption is promoted by a characteristic frequency dispersion in the applied frequency range (β/δ dispersion [108]). The active nonthermal excitation effects also happen in this dispersion range [109], which targets the lipid-protein interactions and selects water-bound states [110] at the membrane, effectively focusing the energy on the target [111]. This high frequency promotes dipolar processes of proteins and other large molecules (like cellular organelles, biopolymers) [112], and is active on the suspended particles surrounded by cells [113], as well as may modify the protein-bound water, and cell organelles such as mitochondria [114] [115]. The excitation of the transmembrane proteins, charging intercellular structures and electrochemical changes mostly happen in lower frequencies (α -dispersion). To achieve the complete effect of selecting and modifying the TME the combination of the high and low frequencies offers the optimum. The high frequency component is used as a carrier frequency of the low one which modulates the signal [116] [117]. The current density of the modulated signal has special nonlinear properties, similar to the unmodulated applications (Figure 15).

The charge redistribution and its changing of the applied RF current allow a special memory. In the presence of an alternating current electric field, the behavior of the electrodiffusion becomes time dependent. The time dependent electric field exhibits a memory effect depending on the specific conditions and assumptions. In general, the memory effect refers to a system's response being

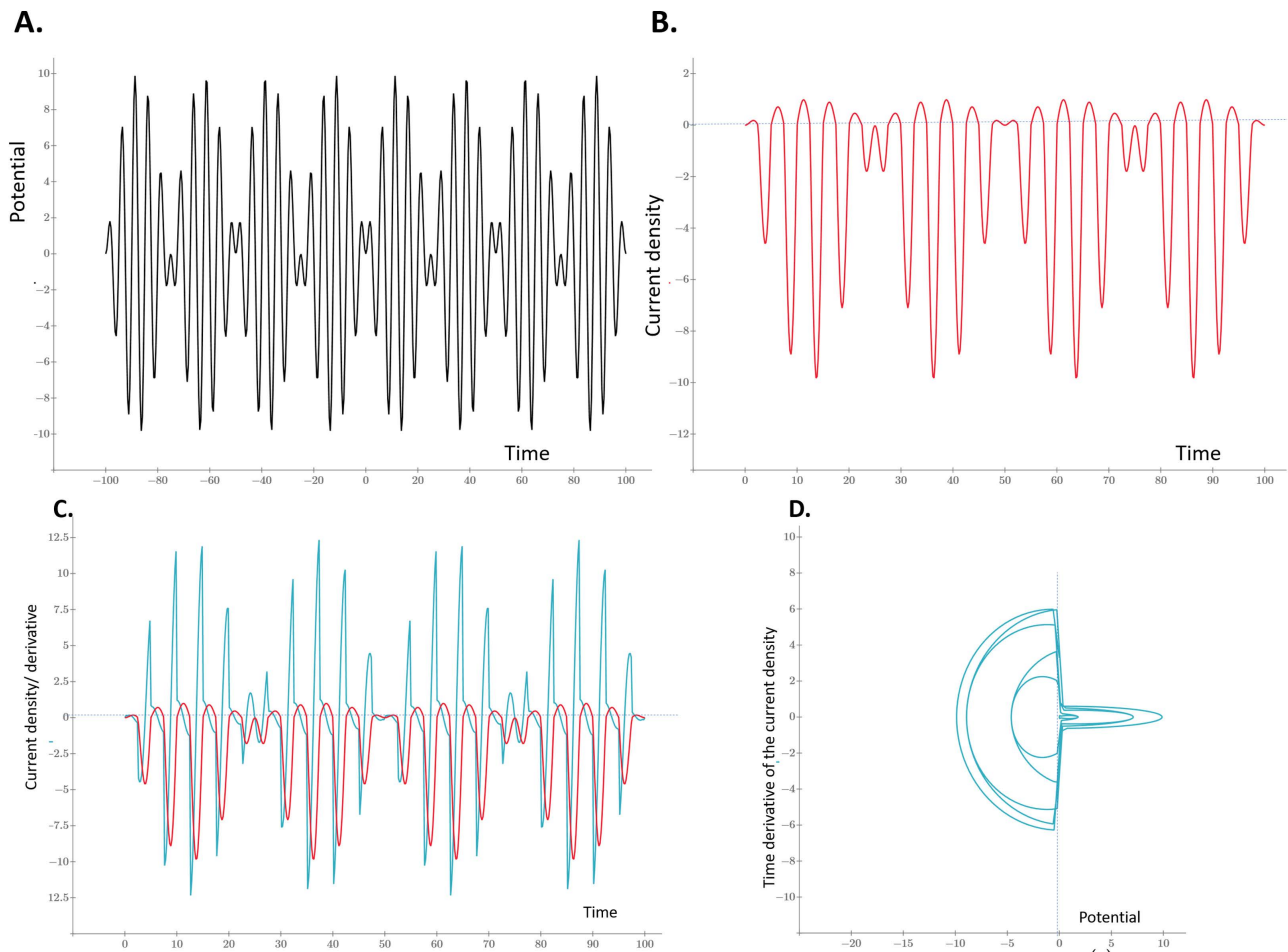

Figure 15. The modulated field makes similar but more complicated behavior than **Figure 12** and **Figure 13**. (A) The modulated external signal. (B) The current density having $C_1/C_2 = 10$. The rectification modifies the time-dependence. (C) The current density and its derivative. (D) The time derivative of current density has hysteresis by the changing potential.

dependent on its previous states or history. In the case of electrodiffusion, if the system exhibits memory, it means that the transport properties of the charged species at a given time depend not only on the current electric field but also on its previous history. The presence of memory can arise if there are mechanisms that introduce temporal dependencies in the transport coefficients, like relaxation processes. The memory element of the discrete electric circuit is the memristor [118] [119]. Memristors are devices that can exhibit electric charge redistribution, known as the memristor effect. As the potential difference changes, so does the resistance. The change in time is determined up to the time constant of the process: the diffusion and the dielectric polarization relaxation. Memristors exhibit a memory-like behaviour by changing their resistance based on the magnitude and direction of the applied electric current. The memristor's memory depends on the charge distribution $w \approx \text{grad}(\rho)$ in the resistive volume, and the resistivity R_m depends on the gradient (w), the current (I) and the time (t), and so the Ohm-law: $V = R_m(w, I, t)I$ in memresistive system [120]. Memristors can indeed exhibit the electric charge redistribution effect. Memristors

are a type of electronic device that can “remember” the amount of charge that has flowed through them in the past states through which the system has evolved.

The memristor is a two-terminal electronic component that can change its resistance in response to the magnitude and direction of the applied voltage or current. This change in resistance is a result of the redistribution of electric charge within the device. The resistivity of memristor depends on the charge (ρ) distribution. The Ohm-law in differential form with V potential, I current and R resistivity:

$$dV(\rho) = R(\rho)dI(\rho) \quad (28)$$

and the voltage depends on the magnetic flux (φ).

$$dV(\rho) = \frac{d\varphi(\rho)}{dt} \quad \text{and} \quad dI(\rho) = \frac{d\rho}{dt} \quad (29)$$

Consequently, the memristive effect, when the flux depends on the charge:

$$M[\rho(t)] = R(\rho) = \frac{d\varphi(\rho)}{d\rho} \quad (30)$$

which was the basic idea of the memristor as a missing circuit element [118 115]. On this way, the biological systems with memristive behaviour, when the relaxation time of space-charge comparable with the one quarter of the exciting electric field time constant, otherwise the quick relaxation does not interact with the field. Then opposite change of the current must happen during the space-charge relaxation processes for the memristive interaction. The charge dependence of the current-density causes an apparent inductive behaviour, the current left behind the voltage, due to the rearranging space charge. The time-lag changes by time, the system “learns”. According (9) the characteristic relaxation time of the space-charge (sc) is $\tau_{sc} \cong 2.5 \times 10^{-9}$ s, which is directly influenced by the quarter of the time-constant of 13.56 MHz carrier frequency ($\frac{\tau_{13.56}}{4} \cong 2.9 \times 10^{-9}$ s), causing the memristor behaviour. The induced space charge by polarization at the boundaries does not complete the rearrangement of the charges. The charge separation at the boundaries introduces non-linearity, having a rectification effect that makes the low-frequency modulation active on the carrier in deeper tissues as well.

The application of memristor principles in living objects is an emerging field of research known as “memristive biology” or “biomemristors.” The application of memristor principles in living objects is a complex and interdisciplinary field. The changing membrane conductance was observed as early as 1940, introducing a variable resistance of the membrane [121], and observing the emphasized rectification [122] an inductive element was introduced [123] [124] (Figure 16). The inductivity directly connects the process to the memristor behavior. The inductive behavior was used in neuronal models [125]. Memristive behaviour of neuronal system was measured with in impedance spectroscopy [126] [127].

Characteristic behaviour of the memristors their charge gradient, which varies by the current density flowing through of it. The heterogenic dropping of the solid materials were the first realizing of the memristive idea [128] (Figure 17).

The capacitance has similar arrangement where the charge and the potential are connected: $q = C_m(w, V, t)V$. In all cases the time derivative of the charge

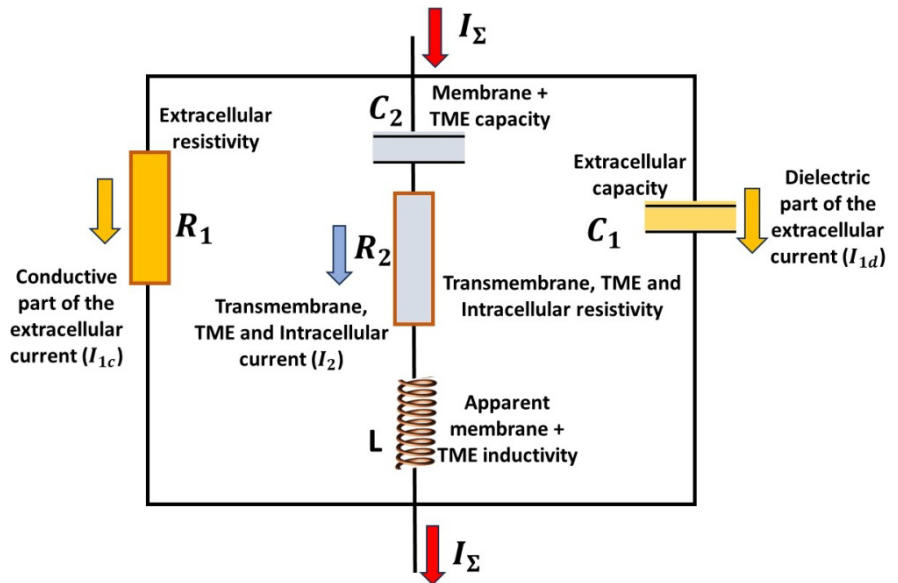

Figure 16. The electro-impedance spectroscopy observed an apparent inductivity in the system, which is shown in the discrete elements of the electric circuit model. The central part of the circuit contains the membrane and its nearest neighborhood as shown in Figure 8(A).

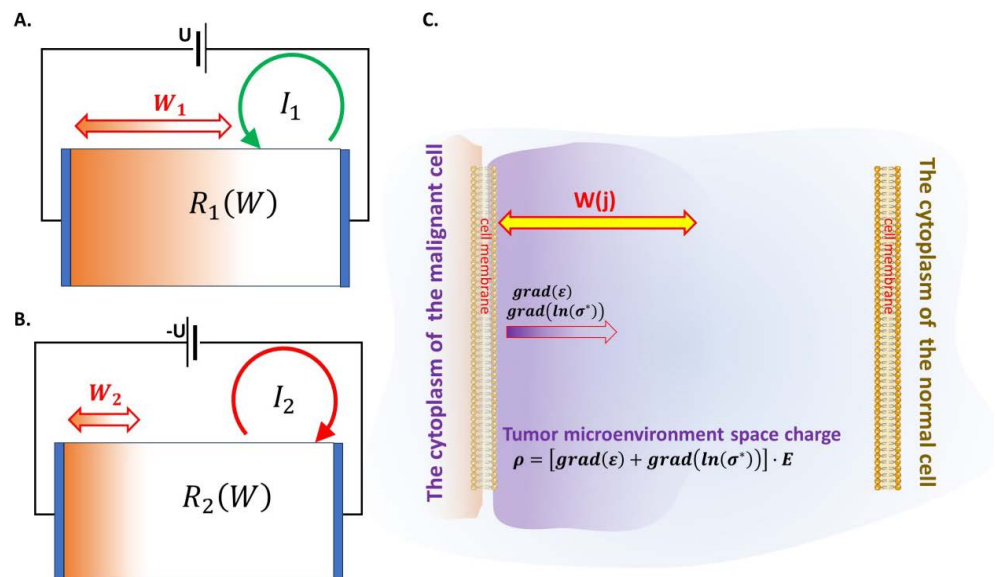

Figure 17. The memristor idea. The resistivity depends on the current direction and intensity, and due to the relaxation times it could be tuned as a memory element. (A) The R_1 resistivity of the memristor depends on the inhomogeneous charge distribution, which widens by a current flowing in the right direction. (B) The current suppress the charge distribution, and the resistivity increases. (C) The space-charge between two cells may behave as a memristor.

gradient is a function with the parameters of the memristor [120]. Memristors can be applied in the synaptic contacts [129] [130], and other memory applications like neuronal calculations [131], perspiration processes [132] and biosensors [133]. Microtubules composed of tubulin dimers are show also memristor effects [134]. Memristors can play a role in developing neuromorphic systems for cancer treatment. Neuromorphic systems mimic the structure and function of the human brain, allowing for intelligent and adaptive treatment strategies. By incorporating memristors into these systems, it is possible to create efficient and dynamic treatment protocols that can adapt to the evolving characteristics of tumors.

The metabolic differences fundamentally deviate the microenvironments of the malignant and healthy cells. The fundamental request to generate sufficient ATP and biosynthetic precursors to maintain the intensive cellular fission and proliferation. The ionic distribution at the tumor/normal cellular interface can vary depending on various factors, including the type and stage of the tumor, the specific location within the body, and individual variations among patients. The altered ionic distributions in TME compared to normal ECM can affect several ions, including potassium (K^+), sodium (Na^+), calcium (Ca^{2+}), and chloride (Cl^-). The changes in ion distribution are attributed to the dysregulation of ion channels and transporters in tumor cells. A concentration gradient of the ions and consequently their charge define the interface between the cancer and normal cells. The resistivity of this transition layer changes by charge redistribution which the current flow causes. The conductivity of the layer follows the changes of the electric field. On this way the charge gradient serves as a typical memristor layer (Figure 18). The memristive charge effect appears not only extracellularly,

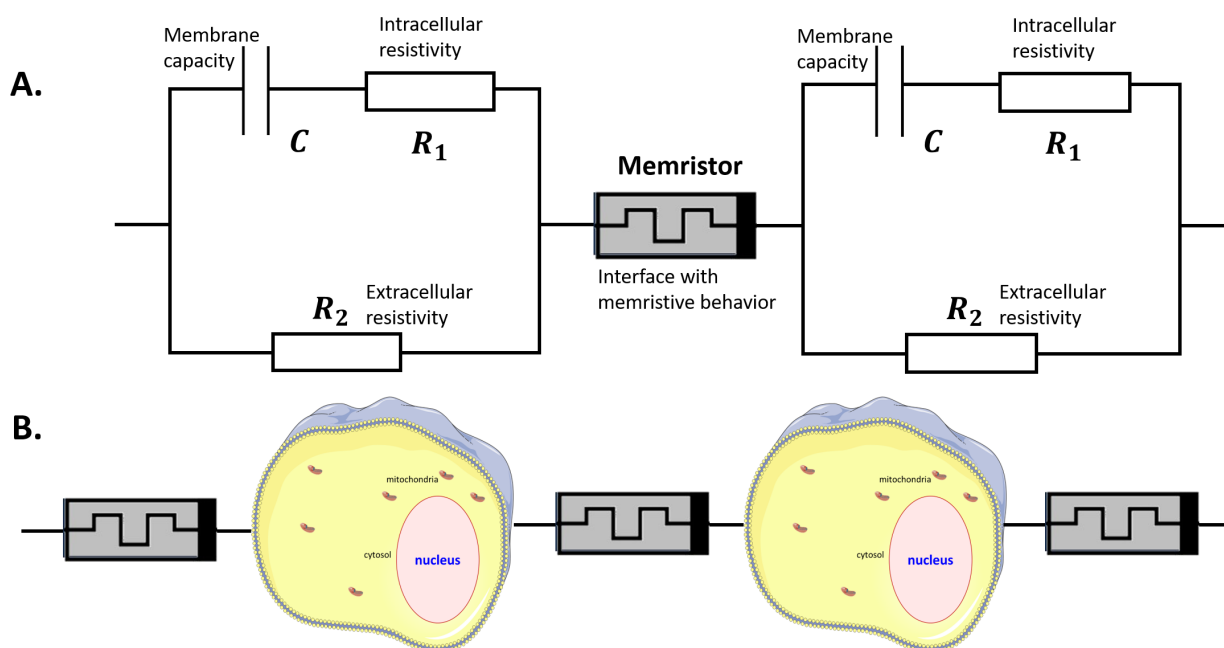

Figure 18. The memristive behaviour of the tissue. The resistivity of this connection depends on the transition charge distribution between the cells and the RF current changes it. (A) The memristive connection between the cells. (B) Memristive chain connection. Space charges form the memristors.

but appears in the ionic channels revising the Hodgkin-Huxley membrane model [135].

The entire body has space-charge connections, electrically networking the structures (Figure 19).

The body and all of its subunits have heterogenic space-charge distribution embedding each other in a complex network (Figure 20).

4. Discussion

The generalized Ohm's law (27) for inhomogeneous media approximates the current density versus field strength. In real cases, various chemical species are transported through tissue. The charge transport is connected to the mass transfer, which could be described by the generalized current densities. Principally, it has two current density components: the drift forced by field strength and the diffusion current driven by the concentration gradients. The uncharged particles

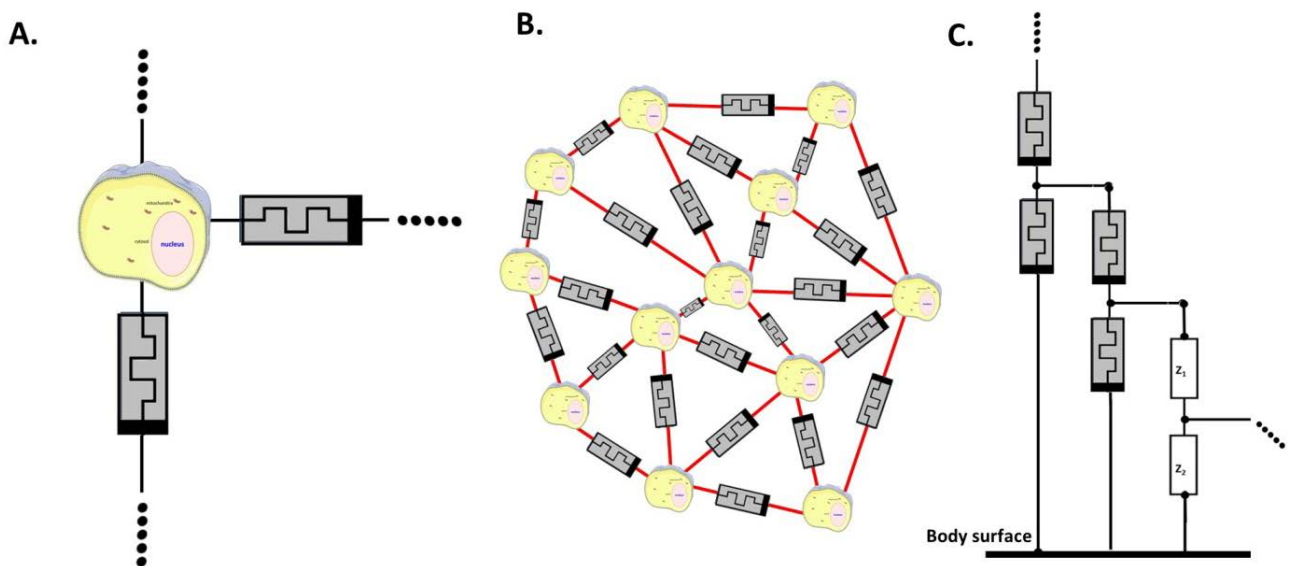

Figure 19. The network forming of the memristors caused by the space charges. (A) cellular space charge connection to the next neighbour cell. (B) Example of the memristor network in a tissue. (C) The subunits of the organism (like organs, tissues) are also connected with space-charge. The body surface is regarded as a common electric reference.

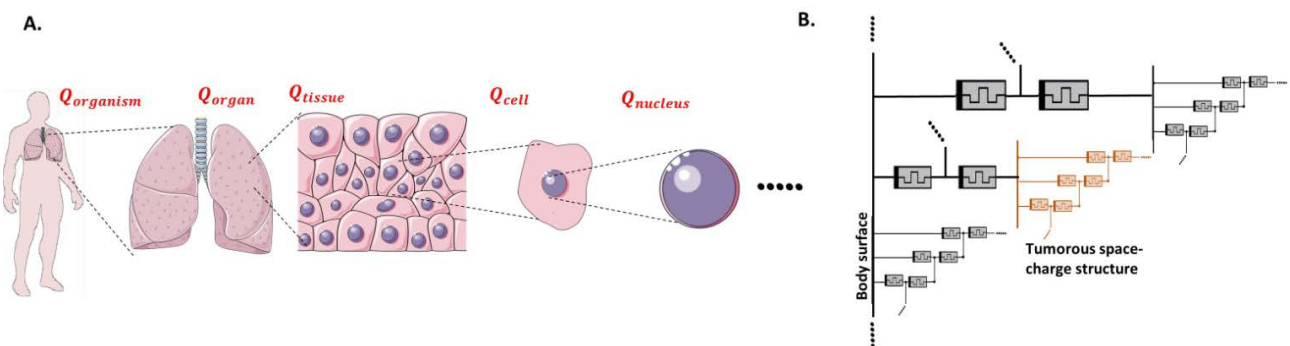

Figure 20. The charge (Q) distribution heterogeneity from organism to cells and beyond. (A) The charge distribution follows the structure of the human body. (B) The tumor represents a deformed charge distribution compared to the healthy structures.

(some molecules, cells and other TME compartments) have only diffusion driving force, but in many cases they're accompanied with charged particles to penetrate to the cell over the membrane barrier. Such happens with inert glucose molecule, which has a Na^+ cotransport allowing their membrane penetration [136]. On this way the inert molecules participate in the electrodiffusion processes.

Hysteresis in the context of electrodiffusion in the tumor microenvironment refers to a phenomenon where the transport of ions or charged particles within the tumor tissue exhibits a time-dependent and non-linear behavior. This behavior is characterized by a lag or delay in the response of ion transport to changes in the applied electrical field or concentration gradients.

In the tumor microenvironment, electrodiffusion involves the movement of charged particles, such as ions or drugs, in response to electric fields or concentration gradients. This process is influenced by various factors, including the tumor's unique physical and biochemical properties. Hysteresis arises due to the complex interplay of these factors and manifests as a disparity between the forward and reverse processes of ion transport.

The hysteresis effect can be explained by the presence of barriers or hindrances within the tumor microenvironment. These barriers may include cellular membranes, extracellular matrix components, or irregularities in tissue structure. As ions or charged particles encounter these barriers, their movement becomes restricted or delayed, leading to a time lag in their transport.

Additionally, the hysteresis effect can be influenced by dynamic changes in the tumor microenvironment, such as alterations in pH, oxygen levels, or the presence of specific molecules. These factors can modulate the properties of cellular membranes, affect the hydration state of the tumor tissue, or induce conformational changes in proteins, further contributing to the hysteresis observed in electrodiffusion.

Understanding and characterizing hysteresis in electrodiffusion within the tumor microenvironment is crucial for the development of effective strategies for targeted drug delivery and electrotherapy. By comprehending the complex dynamics of ion transport and hysteresis, researchers can optimize treatment approaches and enhance the efficiency of drug delivery systems in combating tumors.

The currents driven by the electric heterogeneity of the tissues affect the internal polarization structure. The membrane potential does not induce extra charge flow by its high electric field in normal functions of the body. The polarization forms an internal field opposing the external effect. An internal charge redistribution causes current density between the different imperfect dielectrics. When the integrity of living tissue is perturbed, injury or other disturbances rearranges the actual state, and current is generated due to the potential difference in the conductive media. In the case of an injury, the wound in the epithelium provides a shortcut: its potential tends to zero in this localization. The injury disorders the arrangement of the tissue, and critically changes its dielectric

properties, and the charge balances. The difference in electric field induces an electric current directed to the wound. The current, powered by this process of endogenous field strength, is called the injury current [137]. It is the consequence of the internal rebalancing of the charge distribution without being triggered by an external electric field. The injury current promotes cellular migration (centripetal migration [138]) and proliferation to heal the wound [139] [140]. The frequency of the cell division and space orientation of the cells is determined by the electric field [141].

The injury current certainly plays a central role in wound healing [142]. Injury currents are physiological [143], and their typical value is around $100 \mu\text{A}/\text{cm}^2$ on the physiological potential gradient drops $\sim 100 \text{ mV}/\text{cm}$ and may be extended to the 0.5 - 1 mm distance from the wound [144]. This very weak power ($\sim 0.01 \text{ mW}/\text{g}$) does not increase the local temperature [145]. It can be measured using high-tech methods during the wound-healing process [146] [147] [148]. The induced electric field in the tissue is oriented to the wounded area (Figure 21). The current has an electric circuit loop through the surface of the epithelium, where the electric current travels to the surface from the depth of the wound itself. This electrically controls the wound-healing process and persists as long as the wound exists.

Spontaneous biological charge transfers have a significant role, being one of the basic phenomena of tissue repair [149] [150], and especially control the cells and heal the wound by electrical manipulations [151]. The injury current concept is well proven [26] [139] [152] [153]. It needs sensitive experimental setups to measure, but many invasives [85] [145], and noninvasive [146] [148] [154] measurements have been performed to prove the current experiment.

The malignant cell membrane potential is markedly lower [70] [155] than for normal cells and so its outside surface is less positive (relative negative) than their healthy counterparts [156]. A certain potential gradient between malignant tissue and its healthy neighborhood exists [157]. The gradient acts to promote and direct the cancer-cell migration [158]. There is an argument on the cancerous process as wound repairs [159]. The bio-system falsely recognizes a tumor as a wound and stimulates its environment to heal the irregularity, cure the wound. The injury currents produced by the potential gradients actively support the wound-healing mechanism (Figure 22).

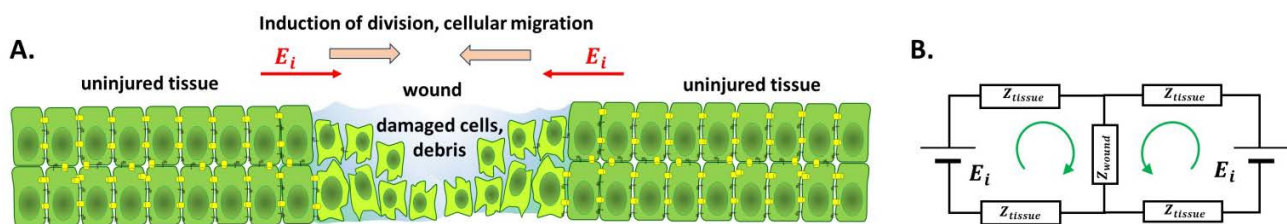

Figure 21. The injury current. (A) The dielectric permittivity and conductivity changes in the damaged tissue. The differences induce an electric field, which promotes the cell proliferation and migration. (B) The electric field drives a current (injury current) from all borders of the wound gaining each other in the damaged volume.

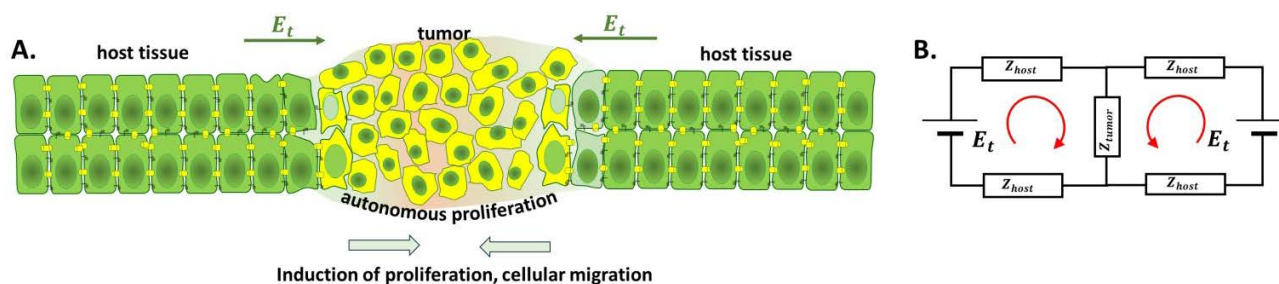

Figure 22. The tumor electronically represents similar conditions than the wound presents. The starting injury current intend to “heal the wound” which supports the tumor-growth.

The adaptation of cancer cells depends on many factors [95] including the special vehicles of information [160], and the main driving originated from the TME as the closest environmental condition [116]. The memristor processes arrange the new charge distribution fit to the actual conditions. The formed space-charge promotes the growing adaptation of cancer cells in a healthy environment. Due to the relative negative charge of cancer, the compensating space-charge constraints electric current to the cancer-disk is formed, starting an injury current between the cancerous and healthy parts. This current could differentiate between the healthy cells and the multipotent ones, which became autonomic and redifferentiated to cancerous. The challenge is the high metabolic rate of the cancerous cells which are in the permanent division and perpetually produce the negative space-charge. The mechanism creates the “precancerous cells” measured by Loewenstein [161]. The dynamic change of the space-charge keeps the injury current active. The process is a self-gaining positive feedback mechanism, while the injury current promotes the cancer proliferation, which promotes the injury current further. The memristor effects between the cells and rapidly “learns” their role, and dynamically adapt the space-charges in the individual TMEs. Therefore the natural mechanisms of the bio-system are not able to block the cancerous development after a definite size.

Artificial intervention to reprogramming the space-charge and block the proliferation mechanisms of the injury current we deliver external field. The near 10 MHz carrier frequency causes the higher electric impact on the malignant cell membrane [162]. However, the effect of body electrolytes on the electrode surface in the chemically reactive biomaterial develops Warburg impedance [163] in the low frequency region, which would be active to rearrange the developing charges. The low frequency modulated high carrier could help to overcome this challenge.

The measured impedance spectroscopy showed significantly higher relaxation time (lower relaxation frequency, where the imaginary part of the impedance is the highest) in malignant tissues than in normal [82] [164]. The higher relaxation time allows also further selection possibilities of malignant cells, to block their proliferative processes.

5. Conclusions

The internal polarization effects form space-charge, which characteristically dif-

fer in malignant and healthy environments. The electrical resistivity of the electrolytes depends on the distribution of the charges and concentrations of ions in the electrolytes, consequently the space-charge differences appear in the conductivity parameters too. The polarization heterogeneities caused by the irregularities of the healthy tissue induce a current (called injury current), which appears in the cancerous tumor as well. Due to the nonlinearity of the space-charge production and the differences of the relaxation time of the processes in various subunits. The tumor develops the space-charge which appears as an inductive component in the otherwise capacitive setting and forms a memristive behavior of the tumorous tissue. This continuously developing space-charge accommodates the tumor to the permanently changing conditions and helps the adopting the malignant cells in the new environment. Applying external radiofrequency electric field, the disturbance of the space-charge may change the conditions, and seek to reestablish the healthy homeostatic equilibrium, blocking the pathologic injury current components.

The hypothetical memristive behavior of the tumor microenvironment and the tumor mass may be a biophysical addition to the adaption mechanisms of tumor cells and could provide a way to block the pathogen biophysical processes.

Conflicts of Interest

The author declares no conflicts of interest regarding the publication of this paper.

References

- [1] Robinson, A.J., Jain, A., Sherman, H.G., Hague, R.J.M., Rahman, R., Sanjuan-Albere, P. and Rawson, F.J. (2020) Toward Hijacking Bioelectricity in Cancer to Develop New Bioelectronic Medicine. *Advanced Therapeutics*, **4**, Article 2000248. <https://doi.org/10.1002/adtp.202000248>
- [2] Zhong, S., Yao, S., Zhao, Q., Wang, Z., Liu, Z., Li, L. and Wang, L.Z. (2023) Electricity-Assisted Cancer Therapy from Traditional Clinic Applications to Emerging Methods Integrated with Nanotechnologies. *Advanced NanoBiomed Research*, **3**, Article 2200143. <https://doi.org/10.1002/anbr.202200143>
- [3] Szasz, A.M., Minnaar, C.A., Szentmartoni, G., *et al.* (2019) Review of the Clinical Evidences of Modulated Electro-Hyperthermia (mEHT) Method: An Update for the Practicing Oncologist. *Frontiers in Oncology*, **9**, Article 1012. <https://doi.org/10.3389/fonc.2019.01012>
- [4] Love, M.R., Palee, S., Chattipakorn, S.C. and Chattipakorn, N. (2018) Effects of Electrical Stimulation on Cell Proliferation and Apoptosis. *Journal of Cellular Physiology*, **233**, 1860-1876. <https://doi.org/10.1002/jcp.25975>
- [5] Krenacs, T., Meggyeshazi, N., Forika, G., *et al.* (2020) Modulated Electro-Hyperthermia-Induced Tumor Damage Mechanisms Revealed in Cancer Models. *International Journal of Molecular Sciences*, **21**, Article 6270. <https://doi.org/10.3390/ijms21176270>
- [6] Lee, S.Y. and Szasz, A. (2022) Immunogenic Effect of Modulated Electro-Hyperthermia (mEHT) in Solid Tumors. In: *Interdisciplinary Cancer Research*. Springer, Cham, 1-28. https://doi.org/10.1007/16833_2022_74

- [7] Qin, W., Akutsu, Y., Andocs, G., *et al.* (2014) Modulated Electro-Hyperthermia Enhances Dendritic Cell Therapy through an Abscopal Effect in Mice. *Oncology Reports*, **32**, 2373-2379. <https://doi.org/10.3892/or.2014.3500>
- [8] Bryant, D.M. and Mostov, K.E. (2008) From Cells to Organs: Building Polarized Tissue. *Nature Reviews Molecular Cell Biology*, **9**, 887-901. <https://doi.org/10.1038/nrm2523>
- [9] Foulds, I.S. and Barker, A.T. (1983) Human Skin Battery Potentials and Their Possible Role in Wound Healing. *British Journal of Dermatology*, **109**, 515-522. <https://doi.org/10.1111/j.1365-2133.1983.tb07673.x>
- [10] Cope, F.W. (1969) Nuclear Magnetic Resonance Evidence Using D2O for Structured Water in Muscle and Brain. *Biophysical Journal*, **9**, 303-319. [https://doi.org/10.1016/S0006-3495\(69\)86388-5](https://doi.org/10.1016/S0006-3495(69)86388-5)
- [11] Leveen, H.H., Wapnick, S., Piccone, V., Falk, G. and Ahmed, N. (1976) Tumor Eradication by Radiofrequency Therapy. *JAMA*, **235**, 2198-2200. <https://doi.org/10.1001/jama.235.20.2198>
- [12] Zhu, M.X. (2011) TRP Channels, Methods in Signal Transduction. CRC Press, Boca Raton, FL.
- [13] Catterall, W.A. (2010) Ion Channel Voltage Sensors: Structure, Function, and Pathophysiology. *Neuron*, **67**, 915-928. <https://doi.org/10.1016/j.neuron.2010.08.021>
- [14] Okamura, Y., Kawanabe, A. and Kawai, T. (2018) Voltage-Sensing Phosphatases: Biophysics, Physiology, and Molecular Engineering. *Physiological Reviews*, **87**, 2097-3231. <https://doi.org/10.1152/physrev.00056.2017>
- [15] Liboff, A.R. (2013) Ion Cyclotron Resonance Interactions in Living Systems. *Atti Iv Convegno Nazionale*, Pavia, Societa Italiana Biofisica Elettrodinamica, 19 October 2013.
- [16] Liboff, A.R. (1997) Electric-Field Ion Cyclotron Resonance (Brief Communication). *Bioelectromagnetics*, **18**, 85-87. [https://doi.org/10.1002/\(SICI\)1521-186X\(1997\)18:1<85::AID-BEM13>3.0.CO;2-P](https://doi.org/10.1002/(SICI)1521-186X(1997)18:1<85::AID-BEM13>3.0.CO;2-P)
- [17] Laity, R.W. (1962) Diffusion of Ions in an Electric Field. *The Journal of Chemical Physics*, **67**, 671-676. <https://doi.org/10.1021/j100797a032>
- [18] Challis, L. (2005) Mechanisms for Interaction between RF Fields and Biological Tissue. *Bioelectromagnetics*, **26**, S98-S106. <https://doi.org/10.1002/bem.20119>
- [19] Alberts, B., Johnson, A., Lewis, J., *et al.* (2002) *Molecular Biology of the Cell*. 4th Edition, Garland Science, New York.
- [20] Fried, S.D. and Boxer, S.G. (2017) Electric Fields and Enzyme Catalysis. *Annual Review of Biochemistry*, **86**, 387-415. <https://doi.org/10.1146/annurev-biochem-061516-044432>
- [21] Goldman, D.E. (1943) Potential, Impedance, and Rectification in Membranes. *Journal of General Physiology*, **27**, 37-60. <https://doi.org/10.1085/jgp.27.1.37>
- [22] Ramachandran, S., Blick, R.H. and van der Weide, D.W. (2010) Radio-Frequency Rectification on Membrane Bound Pores. *Nanotechnology*, **21**, Article 075201. <https://doi.org/10.1088/0957-4484/21/7/075201>
- [23] Tanaka, A. and Tokimasa, T. (1999) Theoretical Background for Inward Rectification. *Tokai Journal of Experimental and Clinical Medicine*, **24**, 147-153.
- [24] Astumian, R.D., Weaver, J.C. and Adair, R.K. (1995) Rectification and Signal Averaging of Weak Electric Fields by Biological Cells. *Proceedings of the National Academy of Sciences of the United States of America*, **92**, 3740-3743. <https://doi.org/10.1073/pnas.92.9.3740>

- [25] Gimsa, J., Marszalek, P., Loewe, U., *et al* (1991) Dielectrophoresis and Electrorotation of Neurospora Slime and Murine Myeloma Cells. *Biophysical Journal*, **60**, 749-760. [https://doi.org/10.1016/S0006-3495\(91\)82109-9](https://doi.org/10.1016/S0006-3495(91)82109-9)
- [26] Zhao, M., Forrester, J.V. and McCaig, A.D. (1999) A Small, Physiological Electric Field Orients Cell Division. *Proceedings of the National Academy of Sciences of the United States of America*, **96**, 4942-4946. <https://doi.org/10.1073/pnas.96.9.4942>
- [27] Kamp, F., Astumian, R.D. and Wesrethoff, H.V. (1988) Coupling of Vectorial Proton Flow to a Biochemical Reaction by Local Electric Interactions. *Proceedings of the National Academy of Sciences of the United States of America*, **85**, 3792-3796. <https://doi.org/10.1073/pnas.85.11.3792>
- [28] Tsong, T.Y. and Chang, C-H. (2003) Ion Pump as Brownian Motor: Theory of Electroconformational Coupling and Proof of Ratchet Mechanism for Na,K-ATPase Action. *Physica A*, **321**, 124-138. [https://doi.org/10.1016/S0378-4371\(02\)01793-4](https://doi.org/10.1016/S0378-4371(02)01793-4)
- [29] Clejan, S., Ide, C., Wlalker, C., *et al.* (1996) Electromagnetic Field Induced Changes in Lipid Second Messengers. *Journal of Lipid Mediators and Cell Signalling*, **13**, 301-324. [https://doi.org/10.1016/0929-7855\(95\)00062-3](https://doi.org/10.1016/0929-7855(95)00062-3)
- [30] Schwan, H.P. (1938) Biophysics of the Interaction of Electromagnetic Energy with Cells and Membranes. In: Grandolfo, M., Michaelson, S.M. and Rindi, A., Eds., *Biological Effects and Dosimetry of Nonionizing Radiation*, Plenum Press, New York, 213-231. https://doi.org/10.1007/978-1-4684-4253-3_9
- [31] Marszalek, P., Liu, D.-S. and Tsong, T.Y. (1990) Schwan Equation and Transmembrane Potential Induced by Alternating Electric Field. *Biophysical Journal*, **58**, 1053-1058. [https://doi.org/10.1016/S0006-3495\(90\)82447-4](https://doi.org/10.1016/S0006-3495(90)82447-4)
- [32] Broude, N., *et al.* (1994) Correlation between the Amplitude of Plasma Membrane Fluctuations and the Response of Cells to Electric and Magnetic Fields. *Bioelectrochemistry and Bioenergetics*, **33**, 19-23. [https://doi.org/10.1016/0302-4598\(94\)87028-4](https://doi.org/10.1016/0302-4598(94)87028-4)
- [33] Burgos-Panadero, R., Lucantoni, F., Gamero-Sandermetrio, E., de la Cruz-Merino, L., Alvaro, T. and Noguera, R. (2019) The Tumour Microenvironment as an Integrated Framework to Understand Cancer Biology. *Cancer Letters*, **461**, 112-122. <https://doi.org/10.1016/j.canlet.2019.07.010>
- [34] Hsu, P.P. and Sabatini, D.M. (2008) Cancer Metabolism: Warburg and Beyond. *Cell*, **134**, 703-707. <https://doi.org/10.1016/j.cell.2008.08.021>
- [35] Egebal, M., Nakasone, E.S. and Werb, Z. (2010) Tumors as Organs: Complex Tissues That Interface with the Entire Organism. *Developmental Cell*, **18**, 884-901. <https://doi.org/10.1016/j.devcel.2010.05.012>
- [36] Bloch, N. and Harel, D. (2016) The Tumor as an Organ: Comprehensive Spatial and Temporal Modeling of the Tumor and Its Microenvironment. *BMC Bioinformatics*, **17**, Article No. 317. <https://doi.org/10.1186/s12859-016-1168-5>
- [37] Warburg, O. (1956) On the Origin of Cancer Cells. *Science*, **123**, 309-314. <https://doi.org/10.1126/science.123.3191.309>
- [38] Warburg, O. (1996) Oxygen, the Creator of Differentiation, Biochemical Energetics. In: Warburg, O., Ed., *The Prime Cause and Prevention of Cancer*, Academic Press, New York, 37-54.
- [39] Garber, K. (2004) Energy Boost: The Warburg Effect Returns in a New Theory of Cancer. *Journal of the National Cancer Institute*, **96**, 1805-1806. <https://doi.org/10.1093/jnci/96.24.1805>
- [40] Oehr, P., Biersack, H.J. and Coleman, RE. (2004) PET and PET-CT in Oncology. Springer Verlag, Berlin-Heidelberg. <https://doi.org/10.1007/978-3-642-18803-9>

- [41] Vaupel, P. and Piazena, H. (2022) Strong Correlation between Specific Heat Capacity and Water Content in Human Tissues Suggests Preferred Heat Deposition in Malignant Tumors upon Electromagnetic Irradiation. *International Journal of Hyperthermia*, **39**, 987-997. <https://doi.org/10.1080/02656736.2022.2067596>
- [42] Silva, A.S., Yunes, J.A., Gillies, R.J. and Gatenby, R.A. (2009) The Potential Role of Systemic Buffers in Reducing Intratumoral Extracellular pH and Acid-Mediated Invasion. *Cancer Research*, **69**, 2677-2684. <https://doi.org/10.1158/0008-5472.CAN-08-2394>
- [43] Alfarouk, K.O., Ahmed, S.B.M., Ahmed, A., Elliott, R.L., Ibrahim, M.E., Ali, H.S., et al. (2020) The Interplay of Dysregulated pH and Electrolyte Imbalance in Cancer. *Cancers (Basel)*, **12**, Article 898. <https://doi.org/10.3390/cancers12040898>
- [44] Chaudhary, S.S., Mishra, R.K., Swarup, A. and Thomas, J.M. (1984) Dielectric Properties of Normal & Malignant Human Breast Tissues at Radiowave & Microwave Frequencies. *Indian Journal of Biochemistry and Biophysics*, **21**, 76-79.
- [45] Surowiec, A.J., Stuchly, S.S., Barr, J.R. and Swarup, A. (1988) Dielectric Properties of Breast Carcinoma and the Surrounding Tissues. *IEEE Transactions on Biomedical Engineering*, **35**, 257-263. <https://doi.org/10.1109/10.1374>
- [46] Joines, W.T., Zhang, Y., Li, C. and Jirtle, R.L. (1994) The Measured Electrical Properties of Normal and Malignant Human Tissues from 50 to 900 MHz. *Medical Physics*, **21**, 547-550. <https://doi.org/10.1118/1.597312>
- [47] Sha, L., et al. (2002) A Review of Dielectric Properties of Normal and Malignant Breast Tissue. *Proceedings IEEE SoutheastCon 2002*, Columbia, 5-7 April 2002, 457-462.
- [48] Gutierrez-Lopez, M., Prado-Olivarez, J., Diaz-Carmona, J., Herrera-Ramirez, C.A., Gutierrez-Gnecchi, J.A. and Medina-Sánchez, C.G. (2019) Electrical Impedance-Based Methodology for Locating Carcinoma Emulators on Breast Models. *Journal of Sensors*, **2019**, Article ID: 8587191. <https://doi.org/10.1155/2019/8587191>
- [49] Smith, S.R., Foster, K.R. and Wolf, G.L. (1986) Dielectric Properties of VX-2 Carcinoma versus Normal Liver Tissue. *IEEE Transactions on Biomedical Engineering*, **BME-33**, Article 522525. <https://doi.org/10.1109/TBME.1986.325740>
- [50] Haemmerich, D., et al. (2003) *In Vivo* Electrical Conductivity of Hepatic Tumors. *Physiological Measurement*, **24**, 251-260. <https://doi.org/10.1088/0967-3334/24/2/302>
- [51] Joines, W.T., Jirtle, R.L., Rafal, M.D. and Schaefer, D.J. (1980) Microwave Power Absorption Differences between Normal and Malignant Tissue. *International Journal of Radiation Oncology · Biology · Physics*, **6**, 681-687. [https://doi.org/10.1016/0360-3016\(80\)90223-0](https://doi.org/10.1016/0360-3016(80)90223-0)
- [52] Babaeizadeh, S. (2007) 3-D Electrical Impedance Tomography of Piecewise Constant Domains with Known Internal Boundaries. *IEEE Transactions on Biomedical Engineering*, **54**, 2-10. <https://doi.org/10.1109/TBME.2006.886839>
- [53] Abdulla, U.G., Buxhtynov, V. and Seif, S. (2020) Cancer Detection through Electrical Impedance Tomography and Optimal Control Theory: Theoretical and Computational Analysis. *Mathematical Biosciences and Engineering*, **18**, 4834-4859. <https://doi.org/10.3934/mbe.2021246>
- [54] Zou, Y. and Guo, Z. (2003) A Review of Electrical Impedance Techniques for Breast Cancer Detection, *Medical Engineering and Physics*, **25**, 79-90. [https://doi.org/10.1016/S1350-4533\(02\)00194-7](https://doi.org/10.1016/S1350-4533(02)00194-7)
- [55] Scholz, B. and Anderson, R. (2000) On Electrical Impedance Scanning—Principles and Simulations. *Electromedica*, **68**, 35-44.
- [56] Muftuler, T.L., Hamamura, M.J., Birgul, O. and Nalcioğlu, O. (2006) *In Vivo* MRI

- Electrical Impedance Tomography (MREIT) of Tumors. *Technology in Cancer Research & Treatment*, **5**, 381-387.
- [57] Mikac, U., Demsar, F., Beravs, K. and Sersa, I. (2001) Magnetic Resonance Imaging of Alternating Electric Currents. *Magnetic Resonance Imaging*, **19**, 845-856. [https://doi.org/10.1016/S0730-725X\(01\)00393-9](https://doi.org/10.1016/S0730-725X(01)00393-9)
- [58] Joy, M., Scott, G. and Henkelman, M. (1989) *In Vivo* Detection of Applied Electric Currents by Magnetic Resonance Imaging. *Magnetic Resonance Imaging*, **7**, 49-54. [https://doi.org/10.1016/0730-725X\(89\)90328-7](https://doi.org/10.1016/0730-725X(89)90328-7)
- [59] Seersa, I., Beravs, K., Dodd, N.J.F., *et al.* (1997) Electric Current Imaging of Mice Tumors. *MRM*, **37**, 404-409. <https://doi.org/10.1002/mrm.1910370318>
- [60] Scott, G.C., Joy, M.L.G., Armstrong, R.L. and Henkelman, R.M. (1995) Electromagnetic Considerations for RF Current Density Imaging. *IEEE Transactions on Medical Imaging*, **14**, 515-524. <https://doi.org/10.1109/42.414617>
- [61] Hossain, S. (2020) Biodielectric Phenomenon for Actively Differentiating Malignant and Normal Cells: An Overview. *Electromagnetic Biology and Medicine*, **39**, 89-96. <https://doi.org/10.1080/15368378.2020.1737804>
- [62] Trainito, C.I., Sweeney, D.C., Cemazar, J., Schmelz, E.M., Francais, O., Le Pioufle, B. and Davalos, R.V. (2019) Characterization of Sequentially-Staged Cancer Cells Using Electrorotation. *PLOS ONE*, **14**, e0222289. <https://doi.org/10.1371/journal.pone.0222289>
- [63] Mavromatos, N.E. (2017) Non-Linear Dynamics in Biological Microtubules: Solitons and Dissipation-Free Energy Transfer. *Journal of Physics: Conference Series*, **880**, Article 012010. <https://doi.org/10.1088/1742-6596/880/1/012010>
- [64] Damadian, R. (1971) Tumor Detection by Nuclear Magnetic Resonance. *Science*, **171**, 1151-1153. <https://doi.org/10.1126/science.171.3976.1151>
- [65] Cope, F.W. (1975) A Review of the Applications of Solid State Physics Concepts to Biological Systems. *Journal of Biological Physics*, **3**, 1-41. <https://doi.org/10.1007/BF02308900>
- [66] Hazlewood, C.F., Nichols, B.L. and Chamberlain, N.F. (1969) Evidence for the Existence of a Minimum of Two Phases of Ordered Water in Skeletal Muscle. *Nature*, **222**, 747-750. <https://doi.org/10.1038/222747a0>
- [67] Hazlewood, C.F., Chang, D.C., Medina, D., *et al.* (1972) Distinction between the Preneoplastic and Neoplastic State of Murine Mammary Glands. *Proceedings of the National Academy of Sciences of the United States of America*, **69**, 1478-1480. <https://doi.org/10.1073/pnas.69.6.1478>
- [68] Chidanbaram, R. and Ramanadham, M. (1991) Hydrogen Bonding in Biological Molecules—An Update. *Physica B*, **174**, 300-305. [https://doi.org/10.1016/0921-4526\(91\)90621-K](https://doi.org/10.1016/0921-4526(91)90621-K)
- [69] Stern, R.G., Milestone, B.N. and Gatenby, R.A. (1999) Carcinogenesis and the Plasma Membrane. *Medical Hypotheses*, **52**, 367-372. <https://doi.org/10.1054/mehy.1997.0657>
- [70] Levin, M. (2007) Large-Scale Biophysics: Ion Flows and Regeneration. *Trends in Cell Biology*, **17**, 261-269. <https://doi.org/10.1016/j.tcb.2007.04.007>
- [71] Alves, A.C., *et al.* (2016) Biophysics in Cancer: The Relevance of Drug-Membrane Interaction Studies. *Biochimica et Biophysica Acta*, **1858**, 2231-2244. <https://doi.org/10.1016/j.bbamem.2016.06.025>
- [72] Gniadecka, M., Nielsen, O.F. and Wulf, H.C. (2003) Water Content and Structure in Malignant and Benign Skin Tumors. *Journal of Molecular Structure*, **661-662**, 405-410.

- <https://doi.org/10.1016/j.molstruc.2003.08.030>
- [73] Beall, P.T., *et al.* (1979) Water-Relaxation Times of Normal, Preneoplastic, and Malignant Primary Cell Cultures of Mouse Mammary Gland. *23rd Annual Meeting of the Biophysical Society*, Atlanta, 26-28 February 1979, A238-A238.
- [74] Chung, S.H., Cerussi, A.E., Klifa, C., *et al.* (2008) *In Vivo* Water State Measurements in Breast Cancer Using Broadband Diffuse Optical Spectroscopy. *Physics in Medicine & Biology*, **53**, 6713-6727. <https://doi.org/10.1088/0031-9155/53/23/005>
- [75] Foster, K.R. and Schepps, J.L. (1981) Dielectric Properties of Tumor and Normal Tissues at Radio through Microwave Frequencies. *Journal of Microwave Power*, **16**, 107-119. <https://doi.org/10.1080/16070658.1981.11689230>
- [76] Szentgyorgyi, A. (1980) The Living State and Cancer. *Physiological Chemistry and Physics*, **12**, 99-110.
- [77] Szentgyorgyi, A. (1998) *Electronic Biology and Cancer*. Marcel Dekker, New York.
- [78] Blad, B. and Baldetorp, B. (1996) Impedance Spectra of Tumour Tissue in Comparison with Normal Tissue; a Possible Clinical Application for Electric Impedance Tomography. *Physiological Measurement*, **17**, A105-A115. <https://doi.org/10.1088/0967-3334/17/4A/015>
- [79] Dubois, J.-M. and Rouzair-Dubois, B. (2004) The Influence of Cell-Volume Changes on Tumor Cell Proliferation. *European Biophysics Journal*, **33**, 227-232. <https://doi.org/10.1007/s00249-003-0364-1>
- [80] McRae, D.A. and Esrick, M.A. (1993) Changes in Electrical Impedance of Skeletal Muscle Measured during Hyperthermia. *International Journal of Hyperthermia*, **9**, 247-261. <https://doi.org/10.3109/02656739309022538>
- [81] Szasz, O. and Szasz, A. (2016) Considering Skin Physiology in Capacitive-Coupled Hyperthermia. *Journal of Advances in Physics*, **11**, 3966-3972. <https://cirworld.com/index.php/jap/article/view/206>
<https://doi.org/10.24297/jap.v11i8.206>
- [82] Blad, B., Wendel, P., Jönsson, M., *et al.* (1999) An Electrical Impedance Index to Distinguish between Normal and Cancerous Tissues. *Journal of Medical Engineering & Technology*, **23**, 57-62. <https://doi.org/10.1080/030919099294294>
- [83] Szentgyorgyi, A. (1968) *Bioelectronics: A Study on Cellular Regulations, Defense, and Cancer*. Academic Press, New York, London.
- [84] Blicher, A., Wodzinska, K., Fidorra, M., Winterhalter, M. and Heimburg, T. (2009) The Temperature Dependence of Lipid Membrane Permeability, Its Quantized Nature, and the Influence of Anesthetics. *Biophysical Journal*, **96**, 4581-4591. <https://doi.org/10.1016/j.bpj.2009.01.062>
- [85] McCaig, C.D., Rajniecek, A.M., Song, B. and Zhao, M. (2005) Controlling Cell Behavior Electrically: Current Views and Future Potential. *Physiological Reviews*, **85**, 943-978. <https://doi.org/10.1152/physrev.00020.2004>
- [86] Enderle, J. (2005), Bioelectric Phenomena. In: Enderle, J.D., Blanchard, S.M. and Bronzino, J.D., Eds., *Introduction to Biomedical Engineering (Second Edition)*, *Biomedical Engineering*, Academic Press, Boston, 627-691. <https://doi.org/10.1016/B978-0-12-238662-6.50013-6>
- [87] Gross, L. (2006) Membrane Oscillations Keep Neurons on the Right Track. *PLOS Biology*, **4**, e191. <https://doi.org/10.1371/journal.pbio.0040191>
- [88] Faisal, A.A., Selen, L.P.J. and Wolpert, D.M. (2008) Noise in the Nervous System. *Nature Reviews Neuroscience*, **9**, 292-303. <https://doi.org/10.1038/nrn2258>
- [89] Schaeffer, A.T., Angelo, K., Spors, H. and Margrie, T.W. (2006) Neuronal Oscilla-

- tions Enhance Stimulus Discrimination by Ensuring Action Potential Precision. *PLOS Biology*, **4**, e163. <https://doi.org/10.1371/journal.pbio.0040163>
- [90] Wang, Y., *et al.* (2021) Correlation between Electrical Characteristics and Biomarkers in Breast Cancer Cells. *Scientific Reports*, **11**, Article No. 14294. <https://doi.org/10.1038/s41598-021-93793-6>
- [91] Szasz, A. (2022) Heterogeneous Heat Absorption Is Complementary to Radiotherapy. *Cancers*, **14**, Article 901. <https://doi.org/10.3390/cancers14040901>
- [92] Debye, P. (1913) Zur Theorie der anomalen dispersion im Gebiete der langwelligen Elektrischen Strahlung. Druck von Friedr. Vieweg & Sohn.
- [93] Schwan, H.P. (1963) Determination of Biological Impedances. In: Nastuk, W.L., Ed., *Electrophysiological Methods. Physical Techniques in Biological Research*, Academic Press, New York, 323-406. <https://doi.org/10.1016/B978-1-4831-6743-5.50013-7>
- [94] Schwan, H.P., Takashima, S., Miyamoto, V.K. and Stoeckenius, W. (1970) Electrical Properties of Phospholipid Vesicles. *Biophysical Journal*, **10**, 1102-1119. [https://doi.org/10.1016/S0006-3495\(70\)86356-1](https://doi.org/10.1016/S0006-3495(70)86356-1)
- [95] Ivey, J.W., Bonakdar, M., Kanitkar, A., Davalos, R.V. and Verbridge, S.S. (2016) Improving Cancer Therapies by Targeting the Physical and Chemical Hallmarks of the Tumor Microenvironment. *Cancer Letters*, **380**, 330-339. <https://doi.org/10.1016/j.canlet.2015.12.019>
- [96] Mafe, S., Pellicer, J. and Aguilera, V.M. (1986) Ionic Transport and Space Charge Density in Electrolytic Solutions as Described by Nernst-Planck and Poisson Equations. *The Journal of Physical Chemistry*, **90**, 6045-6050. <https://doi.org/10.1021/j100280a117>
- [97] Szigeti, G., Szasz, A.M. and Szasz, A. (2020) The Growth of Healthy and Cancerous Tissues. *Open Journal of Biophysics*, **10**, 113-128. <https://doi.org/10.4236/ojbiphy.2020.103010>
- [98] Szasz, A. (2019) Thermal and Nonthermal Effects of Radiofrequency on Living State and Applications as an Adjuvant with Radiation Therapy. *Journal of Radiation and Cancer Research*, **10**, 1-17. https://doi.org/10.4103/jrcr.jrcr_25_18
- [99] Szasz, O. (2019) Bioelectromagnetic Paradigm of Cancer Treatment—Modulated Electro-Hyperthermia (mEHT). *Open Journal of Biophysics*, **9**, 98-109. <https://doi.org/10.4236/ojbiphy.2019.92008>
- [100] Ferenczy, G.L. and Szasz, A. (2020) Chap. 3. Technical Challenges and Proposals in Oncological Hyperthermia. In: Szasz, A., Ed., *Challenges and Solutions of Oncological Hyperthermia*, Cambridge Scholars Publishing, Newcastle upon Tyne, 72-90. <https://www.cambridgescholars.com/challenges-and-solutions-of-oncological-hyperthermia>
- [101] Szasz, A. (2021) The Capacitive Coupling Modalities for Oncological Hyperthermia, *Open Journal of Biophysics*, **11**, 252-313. <https://doi.org/10.4236/ojbiphy.2021.113010>
- [102] Szasz, A., Szasz, N. and Szasz, O. (2010) *Oncothermia—Principles and Practices*. Springer Science, Heidelberg. <https://doi.org/10.1007/978-90-481-9498-8>
- [103] Andocs, G., Renner, H., Balogh, L., Fonyad, L., Jakab, C. and Szasz, A. (2009) Strong Synergy of Heat and Modulated Electro-Magnetic Field in Tumor Cell Killing, Study of HT29 Xenograft Tumors in a Nude Mice Model. *Strahlentherapie und Onkologie*, **185**, 120-126. <https://doi.org/10.1007/s00066-009-1903-1>
- [104] Bielfeldt, M., Rebl, H., Peters, K., Sridharan, K., Staehlke, S. and Nebe, J.B. (2022)

- Sensing of Physical Factors by Cells: Electric Field, Mechanical Forces, Physical Plasma and Light—Importance for Tissue Regeneration. *Biomedical Materials and Devices*. <https://doi.org/10.1007/s44174-022-00028-x>
- [105] Brumleve, T.R. and Buck, R.P. (1978) Numerical Solution of the Nernst-Planck and Poisson Equation System with Applications to Membrane Electrochemistry and Solid State Physics. *Journal of Electroanalytical Chemistry and Interfacial Electrochemistry*, **90**, 1-31. [https://doi.org/10.1016/S0022-0728\(78\)80137-5](https://doi.org/10.1016/S0022-0728(78)80137-5)
- [106] Schauble, M.K. and Habal, M.B. (1969) Electropotentials of Tumor Tissue. *Journal of Surgical Research*, **9**, S17-S20. [https://doi.org/10.1016/0022-4804\(69\)90127-9](https://doi.org/10.1016/0022-4804(69)90127-9)
- [107] Stubbe, M. and Gimsa, J. (2015) Maxwell's Mixing Equation Revisited: Characteristic Impedance Equations for Ellipsoidal Cells. *Biophysical Journal*, **109**, 194-208. <https://doi.org/10.1016/j.bpj.2015.06.021>
- [108] Caduff, A., Talary, M.S. and Zakharov, P. (2010) Cutaneous Blood Perfusion as a Perturbing Factor for Noninvasive Glucose Monitoring. *Diabetes Technology & Therapeutics*, **12**, 1-9. <https://doi.org/10.1089/dia.2009.0095>
- [109] Schwan, H.P. (1982) Nonthermal Cellular Effects of Electromagnetic Fields: AC-Field Induced Ponderomotoric Forces. *British Journal of Cancer*, **45**, 220-224.
- [110] Pething, R. (1979) Dielectric, and Electronic Properties of Biological Materials. John Wiley and Sons, New York.
- [111] Szasz, O., Andocs, G., Kondo, T., Rehman, M.U., Papp, E. and Vancsik, T. (2015) Heating of Membrane Raft of Cancer-Cells. ASCO Annual Meeting. *Journal of Clinical Oncology*, **33**, e22176. https://doi.org/10.1200/jco.2015.33.15_suppl.e22176
- [112] Asami, K. (2002) Characterization of Biological Cells by Dielectric Spectroscopy. *Journal of Non-Crystalline Solids*, **305**, 268-277. [https://doi.org/10.1016/S0022-3093\(02\)01110-9](https://doi.org/10.1016/S0022-3093(02)01110-9)
- [113] Pauly, H. and Schwan, H.P. (1959) Über die Impedanz einer Suspension von Kugelförmigen Teilchen mit einer Schale. *Zeitschrift für Naturforschung B*, **14**, 125-131. <https://doi.org/10.1515/znb-1959-0213>
- [114] Stoy, R.D., Foster, K.R. and Schwan, H.P. (1982) Dielectric Properties of Mammalian Tissues from 0.1 to 100 MHz: A Summary of Recent Data. *Physics in Medicine and Biology*, **27**, 501-513. <https://doi.org/10.1088/0031-9155/27/4/002>
- [115] Gotz, M., Karsch, L. and Pawelke, J. (2017) A New Model for Volume Recombination in Plane-Parallel Chambers in Pulsed Fields of High Dose-per-Pulse. *Physics in Medicine & Biology*, **62**, 8634-8654. <https://doi.org/10.1088/1361-6560/aa8985>
- [116] Minnaar, C.A. and Szasz, A. (2022) Forcing the Antitumor Effects of HSPs Using a Modulated Electric Field. *Cells*, **11**, Article 1838. <https://doi.org/10.3390/cells11111838>
- [117] Szasz, A. (2022) Stimulation and Control of Homeostasis. *Open Journal of Biophysics*, **12**, 89-131. <https://doi.org/10.4236/ojbiphy.2022.122004>
- [118] Chua, L. (1971) Memristor—The Missing Circuit Element. *IEEE Transactions on Circuit Theory*, **18**, 507-519. <https://doi.org/10.1109/TCT.1971.1083337>
- [119] Chua, L. and Kang, S.M. (1976) Memristive Devices and Systems. *Proceedings of the IEEE*, **64**, 209-223. <https://doi.org/10.1109/PROC.1976.10092>
- [120] DiVentra, M., Pershin, Y.V. and Chua, L.O. (2009) Putting Memory into Circuit Elements: Memristors, Memcapacitors and Meminductors. *Proceedings of the IEEE*, **97**, 1371-1372. <https://doi.org/10.1109/JPROC.2009.2022882>
- [121] Cole, K.S. and Baker, R.F. (1940) Transverse Impedance of the Squid Giant Axon during Current Flow. *Journal of General Physiology*, **24**, 535-549.

- <https://doi.org/10.1085/jgp.24.4.535>
- [122] Cole, K.S. and Baker, R.F. (1941) Membrane Potential of the Squid Giant Axon during Current Flow. *Journal of General Physiology*, **24**, 551-563. <https://doi.org/10.1085/jgp.24.4.551>
- [123] Cole, K.S. and Baker, R.F. (1941) Longitudinal Impedance of the Squid Giant Axon. *Journal of General Physiology*, **24**, 771-788. <https://doi.org/10.1085/jgp.24.6.771>
- [124] Cole, K.S. (1941) Rectification and Inductance in the Squid Giant Axon. *Journal of General Physiology*, **25**, 29-51. <https://doi.org/10.1085/jgp.25.1.29>
- [125] Hodgkin, A.L. and Huxley, A.F. (1952) A Quantitative Description of Membrane Current and Its Application to Conduction and Excitation in Nerve. *The Journal of Physiology*, **117**, 500-544. <https://doi.org/10.1113/jphysiol.1952.sp004764>
- [126] Bou, A. and Bisquert, J. (2021) Impedance Spectroscopy Dynamics of Biological Neural Elements: From Memristors to Neurons and Synapses. *The Journal of Physical Chemistry B*, **125**, 9934-9949. <https://doi.org/10.1021/acs.jpcc.1c03905>
- [127] Bisquert, J. (2022) Hopf Bifurcations in Electrochemical, Neuronal, and Semiconductor Systems Analysis by Impedance Spectroscopy. *Applied Physics Reviews*, **9**, Article 011318. <https://doi.org/10.1063/5.0085920>
- [128] Strukov, D.B., Snider, G.S., Stewart, D.R. and Williams, R.S. (2008) The Missing Memristor Found. *Nature*, **453**, 80-83. <https://doi.org/10.1038/nature06932>
- [129] Erokhin, V., Berzina, T., Camorani, P., Smerieri, A., Vavoulis, D., Feng, J. and Fontana, M.P. (2011) Material Memristive Device Circuits with Synaptic Plasticity: Learning and Memory. *BioNanoSci*, **1**, 24-30. <https://doi.org/10.1007/s12668-011-0004-7>
- [130] Sung, H.J., Chang, T., Ebong, I., Bhadviya, B.B., Mazumder, P. and Lu, W. (2010) Nanoscale Memristor Device as Synapse in Neuromorphic Systems. *Nano Letters*, **10**, 1297-1301. <https://doi.org/10.1021/nl904092h>
- [131] Wang, S., Song, L., Chen, W., Wang, G., Hao, E., Li, C., Hu, Y., *et al.* (2022) Memristor-Based Intelligent Human-Like Neural Computing. *Advanced Electronic Materials*, **9**, Article 2200877. <https://doi.org/10.1002/aelm.202200877>
- [132] Johnsen, G.K. (2012) An Introduction to the Memristor: A Valuable Circuit Element in Bioelectricity and Bioimpedance. *Journal of Electrical Bioimpedance*, **3**, 20-28. <https://doi.org/10.5617/jeb.305>
- [133] Homsy, R., Al-Azzam, N., Mohammad, B. and Alazzam, A. (2023) Memristive Biosensors for Cancer Biomarkers Detection: A Review. *IEEE Access*, **11**, 19347-19361. <https://doi.org/10.1109/ACCESS.2023.3248683>
- [134] Tuszynski, J.A., Friesen, D., Freedman, H., Sbitnev, V.I., Kim, H., Santelices, I., *et al.* (2020) Microtubules as Sub-Cellular Memristors. *Scientific Reports*, **10**, Article No. 2108. <https://doi.org/10.1038/s41598-020-58820-y>
- [135] Chua, L., Sbitnev, V. and Kim, H. (2012) Hodgkin-Huxley Axon Is Made of Memristors. *International Journal of Bifurcation and Chaos*, **22**, Article 1230011. <https://doi.org/10.1142/S021812741230011X>
- [136] Poulsen, S.B., Fenton, R.A. and Rieg, T. (2015) Sodium-Glucose Cotransport. *Current Opinion in Nephrology and Hypertension*, **24**, 463-469. <https://doi.org/10.1097/MNH.0000000000000152>
- [137] Rosch, P.J. and Markov, M.S. (2004) Bioelectromagnetic Medicine. Marcel Dekker Inc., New York. <https://doi.org/10.3109/9780203021651>
- [138] Buck, R.C. (1985) Measurement of Centripetal Migration of Normal Corneal Epithelial Cells in the Mouse. *Investigative Ophthalmology & Visual Science*, **26**, 1296-1299.
- [139] Zhao, M. (2009) Electrical Fields in Wound Healing—An Overriding Signal That

- Directs Cell Migration. *Seminars in Cell & Developmental Biology*, **20**, 674-682. <https://doi.org/10.1016/j.semcdb.2008.12.009>
- [140] Huttenlocher, A. (2007) Wound Healing with Electric Potential. *The New England Journal of Medicine*, **356**, 304-305. <https://doi.org/10.1056/NEJMcibr066496>
- [141] Song, B., Zhao, M., Forrester, J.V., *et al.* (2002) Electrical Cues Regulate the Orientation and Frequency of Cell Division and the Rate of Wound Healing *in Vivo*. *Proceedings of the National Academy of Sciences of the United States of America*, **99**, 13577-13582. <https://doi.org/10.1073/pnas.202235299>
- [142] Reid, B., McCaig, C.D., Zhao, M., *et al.* (2005) Wound Healing in Rat Cornea: The Role of Electric Currents. *The FASEB Journal*, **19**, 379-386. <https://doi.org/10.1096/fj.04-2325com>
- [143] Barker, A.T., Jaffe, L.F. and Vanable Jr., J.W. (1982) The Glabrous Epidermis of Cavies Contains a Powerful Battery. *American Journal of Physiology-Regulatory, Integrative and Comparative Physiology*, **242**, R358-R366. <https://doi.org/10.1152/ajpregu.1982.242.3.R358>
- [144] Samuelsson, L., Jonsson, L. and Stahl, E. (1983) Percutaneous Treatment of Pulmonary Tumors by Electrolysis. *Radiologie*, **23**, 284-287. [https://doi.org/10.1016/0011-2275\(83\)90154-6](https://doi.org/10.1016/0011-2275(83)90154-6)
- [145] Song, B., Zhao, M., Forrester, J., *et al.* (2004) Nerve Regeneration and Wound Healing Are Stimulated and Directed by an Endogenous Electrical Field *in Vivo*. *Journal of Cell Science*, **117**, 4681-4690. <https://doi.org/10.1242/jcs.01341>
- [146] Carbon, M., Wübbeler, G., Mackert, B.-M., *et al.* (2004) Non-Invasive Magnetic Detection of Human Injury Currents. *Clinical Neurophysiology*, **115**, 1027-1032. <https://doi.org/10.1016/j.clinph.2003.12.035>
- [147] Reid, B., Nuccitelli, R. and Zhao, M. (2007) Non-Invasive Measurement of Bioelectric Currents with a Vibrating Probe. *Nature Protocols*, **2**, 661-669. <https://doi.org/10.1038/nprot.2007.91>
- [148] Mackert, B.-M., Mackert, J., Wübbeler, G., Armbrust, F., Wolff, K.-D., Burghoff, M., Trahms, L. and Curio, G. (1999), Magnetometry of Injury Currents from Human Nerve and Muscle Specimens Using Superconducting Quantum Interferences Devices. *Neuroscience Letters*, **262**, 163-166. [https://doi.org/10.1016/S0304-3940\(99\)00067-1](https://doi.org/10.1016/S0304-3940(99)00067-1)
- [149] Becker, R.O. and Selden, G. (1985) *The Body Electric*. Morrow, New York.
- [150] Becker, R.O. (1990) *Cross Currents*. Jeremy P Tarcher Inc., Los Angeles.
- [151] Kloth, L.C. (2005), Electrical Stimulation for Wound Healing: A Review of Evidence from *in Vitro* Studies, Animal Experiments, and Clinical Trials. *The International Journal of Lower Extremity Wounds*, **4**, 23-44. <https://doi.org/10.1177/1534734605275733>
- [152] Cheng, K., Tarjan, P., Oliveira-Gandia, M., *et al.* (1995) An Occlusive Dressing Can Sustain Natural Electrical Potential of Wounds. *Journal of Investigative Dermatology*, **104**, 662-665.
- [153] Zhao, M., Song, B., Pu, J., *et al.* (2006) Electrical Signals Control Wound Healing through Phosphatidylinositol-3-OH Kinase- γ and PTEN. *Nature*, **442**, 457-460. <https://doi.org/10.1038/nature04925>
- [154] Reid, B., Nuccitelli, R. and Zhao, M. (2007) Non-Invasive Measurement of Bioelectric Currents with a Vibrating Probe. *Nature Protocols*, **3**, 661-670. <https://doi.org/10.1038/nprot.2007.91>
- [155] Binggeli, R. and Weinstein, R.C. (1986) Membrane Potentials and Sodium Chan-

- nels: Hypotheses for Growth Regulation and Cancer Formation Based on Changes in Sodium Channels and Gap Junctions. *Journal of Theoretical Biology*, **123**, 377-401. [https://doi.org/10.1016/S0022-5193\(86\)80209-0](https://doi.org/10.1016/S0022-5193(86)80209-0)
- [156] James, A.M., Ambrose, E.J. and Lowick, J.H.B. (1956) Differences between the Electrical Charge Carried by Normal and Homologous Tumor Cells. *Nature*, **177**, 576-577. <https://doi.org/10.1038/177576a0>
- [157] Mycielska, M.E. and Djamgoz, M.B.A. (2004) Cellular Mechanisms of Direct-Current Electric Field Effects: Galvanotaxis and Metastatic Disease. *Journal of Cell Science*, **117**, 1631-1639. <https://doi.org/10.1242/jcs.01125>
- [158] Pu, J., McCaig, C.D., Cao, L., *et al.* (2007) EGF Receptor Signalling Is Essential For Electric-Field-Directed Migration of Breast Cancer Cells. *Journal of Cell Science*, **120**, 3395-3403. <https://doi.org/10.1242/jcs.002774>
- [159] Meng, X. and Riordan, N.H. (2006) Cancer Is a Functional Repair Tissue. *Medical Hypotheses*, **66**, 486-490. <https://doi.org/10.1016/j.mehy.2005.09.041>
- [160] Fan, S.-J., Kroeger, B., Marie, P.P., Bridges, E.M., Mason, J.D., McCormick, K., *et al.* (2020) Glutamine Deprivation Alters the Origin and Function of Cancer Cell Exosomes. *The EMBO Journal*, **39**, e103009. <https://doi.org/10.15252/emj.2019103009>
- [161] Loewenstein, W.R. (1999) *The Touchstone of Life, Molecular Information, Cell Communication and the Foundations of the Life*. Oxford University Press, Oxford, New York, 298-304.
- [162] Taghian, T., Narmoneva, D.A. and Kogan, A.B. (2005) Modulation of Cell Function by Electric Field: A High-Resolution Analysis. *Journal of the Royal Society Interface*, **12**, Article 20150153. <https://doi.org/10.1098/rsif.2015.0153>
- [163] Bard, A.J. and Faulkner, L.R. (2000) *Electrochemical Methods, Fundamentals and Applications*. John Wiley & Sons Inc., New York.
- [164] Moqadam, S.M., Grewal, P.K., Haeri, Z., Ingledew, P.A., Kohli, K. and Golnaraghi, F. (2018) Cancer Detection Based on Electrical Impedance Spectroscopy: A Clinical Study. *Journal of Electrical Bioimpedance*, **9**, 17-23. <https://doi.org/10.2478/joeb-2018-0004>