

Investigation the Correlation between Thermal Bridging and Geometries in Concrete Buildings

Ali Vaseghi* , Craig Capano

Department of Construction Science, Capitol Technology University, Maryland, USA

Email: *avaseghi@captechu.edu

How to cite this paper: Vaseghi, A. and Capano, C. (2023) Investigation the Correlation between Thermal Bridging and Geometries in Concrete Buildings. *Journal of Building Construction and Planning Research*, 11, 87-100.

<https://doi.org/10.4236/jbcpr.2023.114006>

Received: November 11, 2023

Accepted: December 22, 2023

Published: December 25, 2023

Copyright © 2023 by author(s) and Scientific Research Publishing Inc. This work is licensed under the Creative Commons Attribution International License (CC BY 4.0).

<http://creativecommons.org/licenses/by/4.0/>



Open Access

Abstract

This article focuses on the investigation of the correlation between thermal bridging and various geometric configurations. The article employs Quick-Field software for conducting three-dimensional steady-state heat transfer simulations to investigate the thermal behaviors of diverse geometric shapes. Significantly, this study involves the simulation of four distinct geometries including concrete circular, square, rectangular, and triangular column through an insulated concrete layer while all geometries maintain the consistent surface areas. The simulations yield findings indicating that circular thermal bridging has the best thermal performance, while rectangular thermal bridging displays comparatively the lowest thermal efficiency. Furthermore, the results indicate that alterations in the perimeter of thermal bridge interfaces, while maintaining a constant area, exert a more pronounced influence on the thermal performance of the geometries compared to proportional changes in area while preserving the perimeter. The study's findings aid building designers and architects in creating more energy-efficient structural and architectural elements by incorporating thermally efficient geometries and forms.

Keywords

Thermal Bridging, Heat Flux, Building Energy, Building Envelope, Concrete Building

1. Introduction

Buildings consume a significant amount of energy, contributing to approximately 28% of global greenhouse gas emissions [1]. The use of space heating and cooling systems substantially adds to overall energy consumption [2]. The primary cause of space thermal load in buildings is heat loss through the components of the building envelope [3]. The efficiency of building envelope system and the

overall thermal performance of the building are influenced by factors such as construction materials, insulation, and architectural details [4]. When highly conductive materials penetrate thermal insulation, thermal bridging occurs, leading to additional heat loss [5]. For instance, a concrete column connected to an insulated parkade ceiling forms a thermal bridge, interrupting insulation continuity and causing energy loss. Thermal bridging negatively affects occupants' comfort and energy consumption [6], causing problems such as surface condensation, mold growth, and structural damage [7].

Various studies underline the impact of thermal bridging on overall building thermal performance and moisture condensation. In some buildings up to 50% of their envelope area comprised of structural assemblies that create thermal bridges [8]. Heat loss through concrete slabs can reduce wall thermal performance by up to 62% [9]. The presence of thermal bridges can decrease the thermal performance of entire walls by up to 28% [10]. Hemmati *et al.* demonstrated that specific configurations of building envelope elements, such as cantilevered balconies and balconies featuring full-depth overhangs, exhibit a higher susceptibility to condensation compared to other slab designs [11]. This vulnerability is attributed to thermal bridging effects. Depending on building construction, thermal bridges' negative effects can be as high as 34% [12]. Highly insulated buildings can lose up to 30% of heating energy due to thermal bridging, while a typical low-rise cold-climate building's annual heating load can rise by 18% [13] [14]. Therefore, designing energy-efficient building envelope details to minimize heat loss and thermal bridging is a key goal for building designers and consultants, especially with the stricter energy standards of modern building codes like ASHRAE, Net Zero Buildings, Passive House Buildings, and LEED Green Building [15] [16] [17] [18].

To enhance thermal performance of buildings, there are strategies that include increasing insulation, using high-performance products, and implementing efficient building envelope designs [19]. An example of high-performance products is Structural Insulated Panels (SIPs), consisting of rigid insulation between structural panels, reduce framing area and thermal bridging [20]. Another example is the thermal break for concrete suspended slabs and columns, with low thermal conductivity to minimize heat transfer [21]. This product has been engineered to exhibit low thermal conductivity, thereby minimizing the transfer of heat through the suspended slab, where interruptions in insulation continuity occur. Goulouti *et al.* investigated the impact of high-performance fiber-reinforced polymer (FRP) thermal breaks on balconies [22]. Through modeling analysis, they established that employing suspended slab FRP thermal breaks substantially reduces heat loss through the slab. Effective designs also incorporate strategies to curtail penetration through insulation and ensure appropriate insulation placement to diminish thermal bridging areas. Ge *et al.* conducted a study suggesting that high performance balconies and slab edges could result in an 11% decrease in the annual heating energy consumption of multi-unit concrete buildings [23]. Vaseghi demonstrated that extending insulation on the top and underside of the

balcony slab can yield an improvement of up to 32% in the component's thermal performance [24].

Nevertheless, the installation of insulation may not always align with structural and architectural constraints. Another pivotal aspect when examining the mitigation of thermal bridging involves the careful consideration of the thermal bridge's geometry and form. In cases where the utilization of high thermal performance materials proves unfeasible or insulation installation is impractical, designers ought to analyze the geometric shape and formulate a design strategy aimed at minimizing heat loss. The objective of this paper is to investigate and compare the thermal performance of various geometries, aiming to comprehend how different shapes and forms impact heat transfer efficiency and overall thermal effectiveness of building envelope components. The results aid architects and building designers in selecting geometries that offer higher thermal performance for building structures, leading to improved energy efficiency and more sustainable building designs.

2. Building Thermal Bridging

2.1. Thermal Bridging Geometries

Thermal bridges in building design exhibit diverse shapes that emerge from a blend of architectural aesthetics and structural considerations. For example, balconies are architectural extensions that project out from the building's façade. While they add an appealing dimension to the design, they can also interrupt the continuous insulation. Balconies are often rectangular in shape. Thermal bridges exhibit in various other shapes as well, including circular or square configurations such as parking garage columns that penetrate through insulated ceilings. This interface of thermal bridging geometry has significant thermal implications. It's not just about visual appeal; it also influences how heat transfers within the building envelope. Thus, design choices resonate beyond the visual spectrum, carrying the potential to impact the building's overall energy efficiency and thermal performance.

Within the domain of thermal bridging, the uniqueness of each shape is defined by two fundamental aspects: its area and perimeter. The area signifies the surface that breaches the insulation, allowing for heat transfer, while the perimeter serves as the boundary that separates the geometric configuration from the encompassing insulation layer. Previously various types of thermal bridging and their respective solutions were discussed [25]. However, the relationship between the area and perimeter of thermal bridging and its impact on thermal performance has not been previously studied. The interplay between the area and perimeter of thermal bridging and its consequential effects on thermal performance is explored in this study. This paper aims to address this gap by modeling and analyzing various thermal bridging geometries that share identical perimeters and areas. The objective is to systematically investigate the influence of the shapes and forms of thermal bridges on overall thermal performance. Through this exploration, an understanding of how geometric variations within thermal

bridging elements can influence heat transfer behavior is attained. This can help building architects and designers to provide more efficient building envelope details and components. The building detail examples are parakde concrete columns penetrating through insulated ceilings or concrete beams that penetrating through insulated walls and roof.

2.2. Thermal Performance Calculations

There are two main approaches for determining the thermal efficiency of a building envelope configuration. The initial technique involves transient heat transfer, encompassing processes of heat transfer in which the temperature within a system evolves over time [26]. This approach accounts for temporal aspects, including the speed at which temperature alterations transpire. It entails the solution of time-dependent heat conduction equations and the incorporation of factors such as time-varying boundary conditions, initial conditions, material characteristics, heat retention, and thermal inertia [27].

The second approach entails steady-state heat transfer, addressing heat transfer processes in which the temperature within a system remains consistent over time [28]. This technique presupposes a state of equilibrium, wherein the pace of heat transfer into the system matches the pace of heat transfer out of the system. It involves solving equations for steady-state heat conduction, wherein temperature gradients and heat flow rates are regarded as unchanging [29]. By assuming an unvarying temperature distribution, this approach streamlines the analysis. Consequently, transient heat transfer analysis accommodates time-evolving temperature and heat transfer variations, whereas steady-state heat transfer analysis adopts a uniform temperature profile for simplified computations.

Transient heat transfer analysis finds application when investigating heat transfer phenomena or scenarios involving substantial temperature variations across time [30]. Conversely, steady-state heat transfer analysis proves advantageous in evaluating systems that have attained a consistent operational state, like the steady-state heat conduction within building envelopes [31]. Although transient heat transfer computations yield more precise outcomes, they demand considerable time and necessitate robust computational resources and specialized software [32]. Given that the objective of this study is to compare and assess thermal efficiency, we employ steady-state heat transfer calculations.

Within steady-state heat transfer computations, the heat transfer rate across a solid entity manifests a direct proportionality to the temperature gradient and the cross-sectional area, while exhibiting an inverse proportionality to the object's thickness [33]. This relationship can be mathematically expressed as Equation (1):

$$Q = U \cdot A \cdot (\Delta T) \quad (1)$$

$$U = k/L$$

$$U = 1/R$$

where;

Q = Heat flow in watt (W)

T = Temperature difference in kelvin (K)

A = Exposed surface area in square meter (m^2)

L = Length in meter (m)

U = Thermal conductance ($W/m^2 \cdot K$)

R = Thermal Resistance ($m^2 \cdot K/W$)

k = Thermal conductivity ($W/m \cdot K$)

In scenarios involving heat transfer across multiple layers or diverse materials, it becomes crucial to consider the comprehensive thermal resistance or U-value of the system. This entails aggregating the individual thermal resistances of each layer to evaluate the holistic heat transfer attributes [34]. A frequently employed technique is the parallel path method, which posits that heat transfers autonomously and concurrently through each distinct material within a plate or system [35].

Furthermore, ASHRAE 90.1 has developed a range of formulas and provided tables specifically tailored for calculating the thermal performance of building envelope components with multiple layers. These resources serve as valuable guidance and assistance in accurately determining heat flow through complex, non-uniform systems. In addition, various software options are available that utilize two-dimensional and three-dimensional finite element models to compute the thermal performance of building envelopes [36]. These software solutions offer advanced capabilities for accurately analyzing and simulating heat transfer within intricate building systems. The following section will introduce the thermal bridging geometries and the computer software employed in this study.

3. Methodology

3.1. Thermal Performance Calculations

This paper embarks on exploration of the thermal efficiency characteristic in the most common thermal bridging geometry in concrete buildings. Each specific detail under analysis entails the composition of an Extruded Polystyrene Rigid Insulation (XPS) layer installed to the exterior surface of a concrete layer. Within the confines of each detail, a solid concrete column is considered, that penetrates the insulation layer and establishes a connection with the concrete layer underneath and represents structural thermal bridges. Both the XPS layer and the concrete layer maintain a uniform thickness of 0.10 m. Notably, the column thermal bridge's geometry extends to a depth of 1 m. The array of thermal bridging geometries under investigation includes circular, square, rectangular, and triangular configurations. For context, the plane outlined by the concrete and XPS layers spans dimensions of 2.4 m by 2.4 m. This specific dimension is chosen to ensure a minimum clearance of 1 m from the thermal bridge's edge to the edge of the concrete layer for each assembly.

This calculated arrangement accommodates a range of thermal bridging geometries while maintaining the desired spacing between the thermal bridge's

boundary and that of the concrete layer. This precision adheres to the recommendations outlined in the ISO 10211:2017 Standard, aligning with adiabatic cut-off plane protocols. **Figure 1** illustrates the geometry of a circular thermal bridge [37].

Figure 2 illustrates the geometric configurations of circular, square, rectangular, and triangular thermal bridges. These four geometries have been selected since they are the most commonly used types in structural elements and penetrations of buildings, such as columns. Notably, despite variations in their shapes, all thermal bridges share a consistent area of 0.16 m^2 . This standardization facilitates an analysis of the impact of thermal bridge based on their shapes solely.

Table 1 provides a breakdown of the specific dimensions associated with each geometry. The corresponding perimeters are distinct for each geometry, highlighting their unique shapes and proportions. This table shows a snapshot of the geometric attributes and forms the foundation for subsequent analysis of the thermal performance of these configurations. Triangular thermal bridge has the highest perimeter while circular thermal bridge has the lowest perimeter.

Table 1. Dimension of thermal bridging geometries.

Type	Area m^2	Perimeter m
Circle	0.16	1.41
Square	0.16	1.60
Rectangular	0.16	1.83
Triangle	0.16	2.00

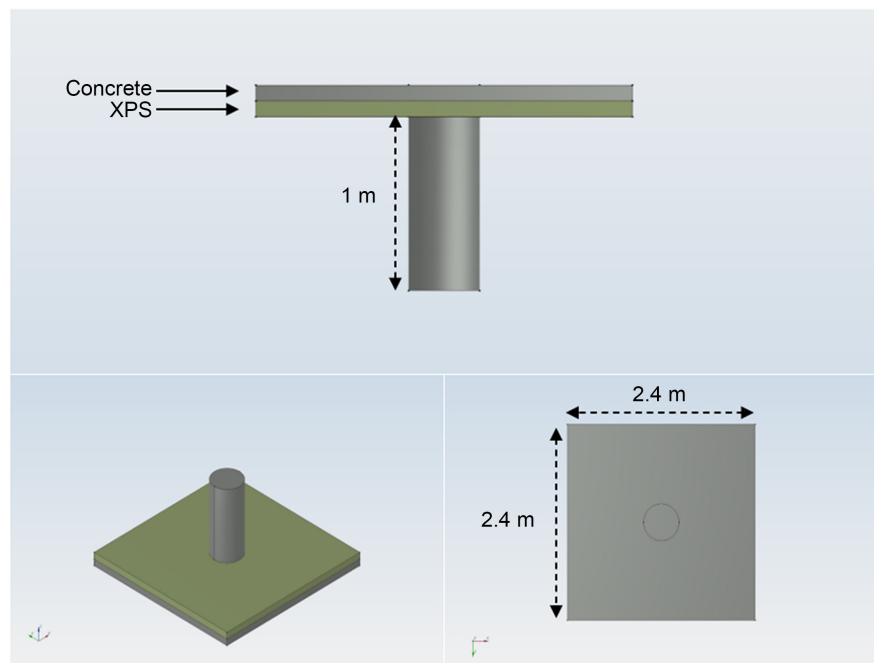

Figure 1. Geometry of circular concrete column and insulated concrete layer.

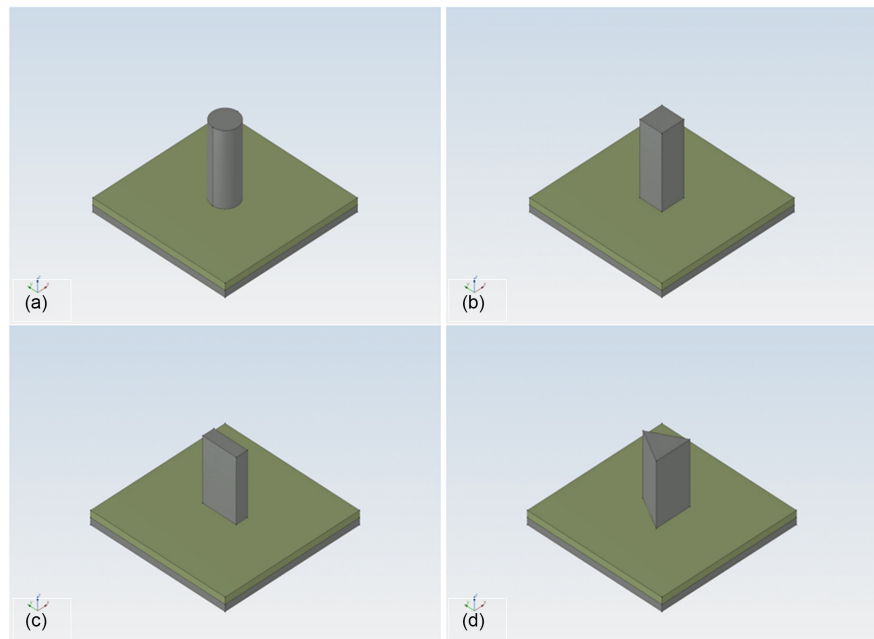

Figure 2. Geometries of (a) circular, (b) square, (c) rectangular, and (d) triangular thermal bridges.

3.2. Simulation Procedure

QuickField software is used in this study to determine the thermal performance of thermal bridging geometries. The Quickfield heat transfer module serves as a tool for examining temperature distributions in static heat transfer scenarios. Within this module, heat sources can be explicitly defined. The versatility of the heat transfer module extends to its applicability in the design and analysis of diverse building systems. Notably, the Heat Transfer module facilitates steady-state heat transfer analysis across various formulations, encompassing three-dimensional extrusion. This flexibility empowers users to explore thermal phenomena across different dimensions and configurations, enhancing the depth and scope of their analyses [38].

The model has been successfully validated following the guidelines outlined in ISO 10211:2017 standard. The validation process involved utilizing four reference cases, calculating both linear and point thermal bridging. The models were tested in accordance with the prescribed procedure of the ISO standard. The simulation results fully comply with all the criteria specified in the ISO Standard, confirming the accuracy and precision of the calculation method used. The heat transfer coefficients for the interior and exterior boundary conditions have been determined using values provided in the 2013 ASHRAE Handbook—Fundamentals [39]. Specifically, a heat transfer coefficient of $34 \text{ W/m}^2\text{K}$ has been selected for exterior surfaces, while an interior wall surface value of $8.3 \text{ W/m}^2\text{K}$ has been chosen. The inside temperature is maintained at 20°C with 65% relative humidity (RH), while outside temperatures have been set to 0°C . The dewpoint temperature for the interior condition is 13.2°C . The simulation

output is heat flux for each geometry as well as interior surface temperature in the center of each detail. The thermal properties are provided as per **Table 1**, Chapter 26 of the 2013 ASHRAE Handbook—Fundamentals. **Table 2** summarizes the thermal property and thickness of each material. The output of the simulations is heat flux (W/m^2) for each model. Heat flux refers to the heat flow (Q) per unit of area.

4. Results

A total of four thermal simulations were conducted. The outcomes of these simulations, illustrating heat flux and interior surface temperature for each geometric shape, are presented in **Figure 3**. For the circular geometry, the heat flux measures $9.7 \text{ W}/\text{m}^2$, while the square geometry exhibits a heat flux of $10.6 \text{ W}/\text{m}^2$. Notably, this marks an approximate 10% increase in heat flux, even as the area remains constant; this increase can be attributed to a rise in perimeter from 1.41 m to 1.60 m. Comparatively, the triangle geometry shows a heat flux of $12 \text{ W}/\text{m}^2$, signifying a considerable 23% heat flux escalation compared to the circular geometry. This enhancement can be attributed to the triangle's perimeter increasing from 1.41 m, as observed in the circular geometry, to 1.83 m. Lastly, the rectangular geometry showcases a heat flux of $13.3 \text{ W}/\text{m}^2$, translating to a substantial 37% surge in heat flux. This augmentation is particularly noteworthy given the rectangular geometry's perimeter of 2.00 m, which surpasses the circular counterpart by 0.59 m.

Table 2. Building material properties.

Material	Thickness m	Thermal Conductivity $\text{W}/\text{m}\cdot\text{k}$
XPS	0.10	0.029
Concrete	0.10	1.80

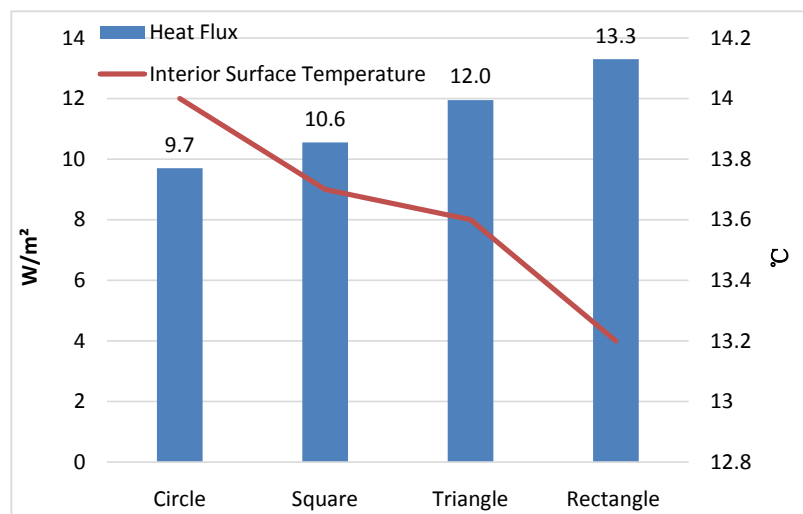

Figure 3. Heat flux and interior surface temperature of geometries based on constant area.

Temperature difference and heat flux share a fundamental and direct relationship, where alterations in temperature difference lead to corresponding changes in heat flux. This interdependence is grounded in the principle that higher temperature disparities across a material or interface result in elevated rates of heat transfer, resulting in greater heat flux. This phenomenon can be comprehended through the lens of the temperature gradient. When the temperature difference between two points is more pronounced, the gradient becomes steeper. Consequently, the driving force for heat transfer intensifies, prompting a more rapid movement of thermal energy from the region of higher temperature to that of lower temperature. In the context of varied geometries, the correlation between heat flux and surface temperature becomes especially intriguing. Geometries that exhibit lower heat flux values are poised to possess higher interior surface temperatures. This connection can be attributed to the fact that reduced heat flux often signifies a lesser rate of heat dissipation, allowing the interior surface to attain higher temperatures. Consider the juxtaposition of circular and rectangular configurations. Circular geometries, due to their inherent symmetry, tend to experience less heat loss and subsequently maintain higher surface temperatures. This can be witnessed in their propensity to surpass the dewpoint temperature, resulting in a reduced likelihood of moisture condensation on their surfaces.

In contrast, rectangular thermal bridges, characterized by their less symmetrical nature, encounter greater heat dissipation, leading to lower surface temperatures. In some instances, these surface temperatures align closely with the dewpoint temperature. Consequently, the risk of moisture condensation becomes more pronounced for rectangular geometries, as the conditions for condensation are more readily met.

Table 3 presents an overview of the variations in heat flux and perimeter increases for different geometries when compared to the reference circular shape. As shifted from the circular configuration to other geometrical forms, such as the square, triangle, and rectangle, distinct patterns of heat flux augmentation and perimeter expansion emerge. Notably, the square geometry demonstrates an 8.8% increase in heat flux and a 13.4% increase in perimeter compared to the circular geometry. This trend accentuates in the case of the triangle, which exhibits a more substantial 23.2% rise in heat flux and a 29.7% expansion in perimeter relative to the circular baseline. The rectangular geometry showcases the most pronounced changes, featuring a significant 37.11% increase in heat flux and a 41.8% surge in perimeter when compared to the circular reference.

Among the four geometries studied, the circular performs best in both heat flux and surface temperature performance, all while maintaining an equal area. This advantageous position can be primarily attributed to the circular geometry's unique characteristic of possessing the smallest perimeter among the options investigated. This streamlined perimeter contributes significantly to a more effective distribution of heat, resulting in improved thermal performance.

Table 3. Correlation between heat flux and geometry.

Geometry	Heat Flux Increase Compared to Circle %	Perimeter Increase Compared to Circle %
Circle	0	0
Square	8.8	13.4
Triangle	23.2	29.7
Rectangle	37.11	41.8

In the next analysis, the interplay between shape, area and their impact on thermal performance, and interior surface temperature is conducted while the perimeter is constant for all four geometries. The perimeter is considered 1.20 m for all four geometries. **Table 4** shows the dimensions of the geometry.

Figure 4 depicts the correlation between thermal performance and geometrical perimeters, while keeping perimeter constant. Among the geometries examined, the triangular shape exhibits the lowest heat flux with 9.0 W/m^2 , followed by the rectangular geometry with 9.3 W/m^2 . It's noteworthy that the triangular and rectangular geometries share identical area and perimeter values. However, this dissimilarity in heat transfer can be attributed to the presence of geometrical thermal bridges. These thermal bridges arise due to alterations in element geometry, causing shifts in heat transfer direction. For instance, the triangle possesses three corners, while the rectangle features four corners. This discrepancy accounts for the slightly enhanced thermal performance of the triangle in comparison to the rectangle. The square geometry records a heat flux of 10.6 W/m^2 . The larger area of the square, in contrast to the triangle and rectangle with identical perimeters, leads to a higher heat flux. Interestingly, the circular geometry demonstrates the least efficient thermal performance among the four shapes. This can be attributed to the circular shape having the greatest perimeter compared to the other configurations. The interior surface temperature is above dew point temperature for all geometries.

Table 5 illustrates the correlation existing between heat flux and geometry, showcasing the extent of heat flux reduction and area reduction percentages in comparison to a circle. The circle itself serves as the reference point. The square geometry exhibits a heat flux reduction of 2.4%, coupled with a 20% area reduction compared to the circle. In contrast, the triangle geometry displays a more substantial heat flux reduction of 16.7% alongside a significant area reduction of 40% relative to the circle. Similarly, the rectangle geometry demonstrates a noteworthy heat flux reduction of 13.9%, aligned with a 40% area reduction when compared to the circle. It is worth highlighting that the influence of perimeter variation, while maintaining a constant area, significantly outweighs the impact of area alteration when perimeter remains constant. This observation holds critical implications for the thermal behavior of components. For instance, the alteration of the square's perimeter by 13.4% corresponds to a heat flux modification of roughly 9%, showcasing a substantial relationship. Conversely, when the geometry's area undergoes a 20% change, the resultant heat flux varia-

tion is a mere 2.4%. This discrepancy emphasizes the heightened sensitivity of thermal performance to changes in perimeter as opposed to changes in area. This phenomenon underscores the intricate relationship between geometry and heat transfer, accentuating the importance of perimeter adjustments in effectively managing heat flux within various applications.

While our study utilized simulations to explore heat transfer phenomena, it's important to acknowledge that these simulations inherently involve simplifications of real-world complexities. Notably, our approach did not consider solar heat capacity of the material. Additionally, due to the intricacies of the modeling process, factors such as the inclusion of steel bars within the concrete were omitted, and we assumed perfect contact between layers without any resistance.

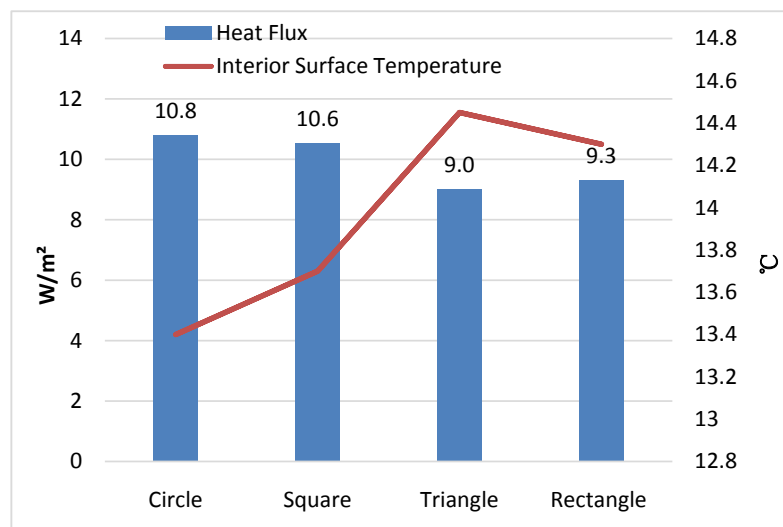

Figure 4. Heat flux and interior surface temperature of geometries based on constant perimeter.

Table 4. Dimension of thermal bridging geometries.

Type	Area m ²	Perimeter m
Circle	0.20	1.60
Square	0.16	1.60
Rectangular	0.12	1.60
Triangle	0.12	1.60

Table 5. Correlation between heat flux and geometry.

Geometry	Heat Flux Increase Compared to Circle %	Area Increase Compared to Circle %
Circle	0	0
Square	2.4	20
Triangle	16.7	40
Rectangle	13.9	40

These limitations provide opportunities for future research to delve into more comprehensive models that can incorporate these factors, thereby advancing our understanding of heat transfer in practical applications.

5. Conclusions

This study has explored the multifaceted interplay between geometric configurations and their influence on thermal performance, yielding valuable insights applicable across diverse geometric domains.

Four distinct concrete geometries, including circular, square, rectangular, and triangular columns penetrating through an insulated concrete layer, have been modeled under three-dimensional steady-state conditions. The geometries have been characterized as thermal bridges. By analyzing the simulation results, correlations between heat flux and geometry have been identified. With a constant area for all four geometries, circular thermal bridges exhibit the highest performance, followed by square and triangular geometries. Rectangular geometry demonstrates the lowest thermal performance. In the second series of simulations, the correlation between thermal performance and geometry area has been investigated, while maintaining a constant interface perimeter. The results show the capacity to temper heat flux, evident through the heat flux reduction percentages relative to the circle. The square geometry, for instance, exhibited the least heat flux reduction while the triangle geometry showed the highest heat flux reduction followed by the rectangular geometry.

Furthermore, a pivotal revelation emerged concerning the varying impact of perimeter and area alterations on thermal performance. This observation underscores that, when maintaining a constant area, perimeter adjustments possess a far more pronounced influence on heat flux dynamics than changes in area with constant perimeter. These findings carry significant implications for the fields of engineering and architecture. They offer opportunities to design more thermally efficient buildings by incorporating more effective geometries and shapes.

Conflicts of Interest

The authors declare no conflicts of interest regarding the publication of this paper.

References

- [1] Masson-Delmotte, V., Zhai, P., Pörtner, H.O., Roberts, D., Skea, J., Shukla, P.R., *et al.* (2018) Global Warming of 1.5°C. An IPCC Special Report on the Impacts of Global Warming of 1.5°C above Pre-Industrial Levels and Related Global Greenhouse Gas Emission Pathways, in the Context of Strengthening the Global Response to the Threat of Climate Change, Sustainable Development, and Efforts to Eradicate Poverty. IPCC. Geneva.
- [2] U.S. Department of Energy (2019) Building Energy Data Book: 2019. <https://buildings.lbl.gov/cbs/bpd/>

- [3] Rosenfeld, A.H., Romm, J.J. and Akbari, H. (1997) Building Energy Efficiency: Best Practice Policies and Future Directions. *Energy Policy*, **25**, 741-753.
- [4] Walker, I.S. and Schweiker, M. (2016) Thermal Performance of the Building Envelope. In: Asdrubali, F. and Desideri, U., Eds., *Handbook of Energy Efficiency in Buildings*, Elsevier, Amsterdam, 143-167.
- [5] Morrison Hershfield (2021) Building Envelope Thermal Bridging Guide (BETB) (Version 1.6).
https://morrisonhershfield.com/bpa_library/building-envelope-thermal-bridging-guide-betb-v1-4/
- [6] Poirier, M., *et al.* (2017) Assessment of Thermal Bridging and Its Impact on Energy Efficiency and Thermal Comfort in Building Envelopes. *Energy and Buildings*, **144**, 37-46.
- [7] Tariku, F. (2008) Whole Building Heat and Moisture Analysis. Ph.D. Thesis, Concordia University, Montreal.
- [8] Çengel, Y.A. and Ghajar, A.J. (2014) Heat and Mass Transfer: Fundamentals and Applications. McGraw-Hill Education, New York.
- [9] Finch, G., *et al.* (2014) The Importance of Balcony and Slab Edge Thermal Bridges in Concrete Construction. *14th Canadian Conference on Building Science and Technology*, Toronto, 28-30 October 2014, 133-145.
- [10] Sadauskiene, J., Ramanauskas, J. and Vasylius, A. (2020) Impact of Point Thermal Bridges on Thermal Properties of Building Envelope. *Thermal Science*, **24**, 2181-2188.
<https://doi.org/10.2298/TSCI180719299S>
- [11] Hemmati, F., Vaseghi, A. and Tariku, F. (2017) Risk of Condensation Analysis of Common Concrete Balcony Configurations (LV-17-C063). *2017 ASHRAE Winter Conference*, Las Vegas, 28 January 2017, 8-16.
- [12] Ilomets, S., Kuusk, K., Paap, L., Arumägi, E. and Kalamees, T. (2016) Impact of Linear Thermal Bridges on Thermal Transmittance of Renovated Apartment Buildings. *Journal of Civil Engineering and Management*, **23**, 96-104.
<https://doi.org/10.3846/13923730.2014.976259>
- [13] Theodosiou, T.G. and Papadopoulous, A.M. (2008) The Impact of Thermal Bridges on the Energy Demand of Buildings with Double Brick Wall Constructions. *Energy and Buildings*, **40**, 2083-2089. <https://doi.org/10.1016/j.enbuild.2008.06.006>
- [14] Ge, H. and Baba, F. (2015) Dynamic Effect of Thermal Bridges on the Energy Performance of a Low-Rise Residential Building. *Energy and Buildings*, **105**, 106-118.
<https://doi.org/10.1016/j.enbuild.2015.07.023>
- [15] ASHRAE (American Society of Heating, Refrigeration and Air-Conditioning Engineers, Inc.) (2019) Energy Efficiency Standard for Buildings Except Low-Rise Residential Buildings. Standard 90.1-2019, Atlanta.
- [16] U.S. Department of Energy (2015) Net Zero Energy Buildings.
<https://www.energy.gov/sites/prod/files/2015/09/f26/A%20Common%20Definition%20for%20Zero%20Energy%20Buildings.pdf>
- [17] Passive House International (2023) What Is Passive House?
https://passivehouse-international.org/index.php?page_id=150
- [18] LEED (Leadership in Energy and Environmental Design) (2019) LEED V4 for Building Design and Construction. LEED V4-2019, Atlanta.
- [19] ASHRAE (American Society of Heating, Refrigerating and Air-Conditioning Engineers, Inc.) (2015) Advanced Energy Design Guide for Small to Medium Office Buildings: Achieving 50% Energy Savings toward a Net Zero Energy Building. At-

- lanta.
- [20] (2023) SIPA—Structural Insulated Panel Association. <https://www.sips.org/>
 - [21] Havret, T., Atanasiu, B. and Ganachaud, M. (2016) Innovative Thermal Breaks for Sustainable Buildings: State-of-the-Art and Future Challenges. *Sustainability*, **8**, Article 660.
 - [22] Goulouti, K., *et al.* (2014) Thermal Performance Evaluation of Fiber-Reinforced Polymer Thermal Breaks for Balcony Connections. *Energy and Buildings*, **70**, 365-371. <https://doi.org/10.1016/j.enbuild.2013.11.070>
 - [23] Ge, H., McClung, R. and Zhang, S. (2013) Impact of Balcony Thermal Bridges on Overall Thermal Performance of Residential Buildings. *Energy and Buildings*, **67**, 307-315.
 - [24] Vaseghi, A. (2020) Building Envelope Designs to Improve Thermal Performance of Concrete Buildings. Master's Thesis, British Columbia Institute of Technology, Vancouver.
 - [25] Alhawari, A. and Mukhopadhyaya, P. (2018) Thermal Bridges in Building Envelopes—An Overview of Impacts and Solutions. *International Review of Applied Sciences and Engineering*, **9**, 31-40. <https://doi.org/10.1556/1848.2018.9.1.5>
 - [26] Straube, J. and Burnett, E. (2016) Building Science for Building Enclosures. Building Science Press, Westford.
 - [27] Mills, A.F. (2010) Heat Transfer. 2nd Edition, Prentice Hall, Upper Saddle River.
 - [28] Çengel, Y.A. and Ghajar, A.J. (2014) Heat and Mass Transfer: Fundamentals and Applications. McGraw-Hill Education, New York.
 - [29] Özisik, M.N. (1985) Heat Conduction. 2nd Edition, John Wiley & Sons, New York.
 - [30] Hollands, K.G.T., Zeng, R. and Simpkin, A. (2017) Transient Heat Transfer Analysis in Building Envelope Design. *Energy Procedia*, **132**, 1009-1014.
 - [31] Chang, Y., Wang, F. and Wu, X. (2018) Analysis of Steady-State Heat Transfer in Building Envelopes. *Energy and Buildings*, **160**, 264-275.
 - [32] Incropera, F.P., DeWitt, D.P., Bergman, T.L. and Lavine, A.S. (2019) Introduction to Heat Transfer. Wiley, New York.
 - [33] Omer, S.A. and Zubair, S.M. (2019) Steady-State Heat Transfer Analysis of Building Envelopes: A Review. *Energy Procedia*, **160**, 175-182.
 - [34] Holman, J.P. (2010) Heat Transfer. 10th edition, McGraw-Hill Education, New York.
 - [35] Incropera, F.P., DeWitt, D.P., Bergman, T.L. and Lavine, A.S. (2017) Fundamentals of Heat and Mass Transfer. John Wiley & Sons, New York.
 - [36] Chen, Z., He, T. and Zhu, Y. (2020) Comparative Analysis of Software Tools for the Thermal Performance of Building Envelopes. *Applied Thermal Engineering*, **176**, Article ID: 115381.
 - [37] International Organization for Standardization (2017). ISO 10211:2017 Thermal Bridges in Building Construction—Heat Flows and Surface Temperatures—Detailed Calculations. Geneva.
 - [38] Tera Analysis Ltd (2023) Quick Field [Version 7.0]. Svendborg.
 - [39] ASHRAE (American Society of Heating, Refrigerating and Air-Conditioning Engineers, Inc) (2013) ASHRAE Handbook—Fundamentals.