

# Clarifying the Language of Chance Using Basic Conditional Probability Reasoning: The Monty Hall Problem

Pejmon Sadri

Department of Liberal Arts, Menlo College, Atherton, USA

Email: [psadri@menlo.edu](mailto:psadri@menlo.edu)

Received July 21, 2012; revised August 2, 2012; accepted August 14, 2012

## ABSTRACT

Clarity and preciseness in the use of language is crucial when communicating mathematical and probabilistic ideas. Lack of these can make even the simplest problem difficult to understand and solve. One such problem is the Monty Hall problem. In the past, a controversy was stirred among professional mathematicians when trying to reach a consensus on a solution to the problem. The problem still creates confusion among some of those who are asked to solve it for the first time. We purport to demonstrate the use of more precise language of basic conditional probability could have prevented the controversy.

**Keywords:** Conditional Probability; The Monty Hall Problem

## 1. Introduction

Some loss in the meaning of expressions is expected when information is translated from one language to another. But, *a loss in meaning* isn't the worst byproduct of translating information. Rather, *it's the misconceptions* that are created during the process of conveying a message from one abstract form to another that is the bigger issue [1].

The implication of this for teaching and learning mathematics is significant because a fruitful discussion of mathematical concepts requires facility in simultaneous comprehension of various symbolic representations; Greek letterings, matrices, and asymptotic charts—and above all—one's native tongue that has to connect to all that. Abouhedid and Nasser [2], for example, discuss how communicating information via a web of symbolic, graphical, numeric, and verbose representations can create faulty conceptions in mathematics. They reason that the “structural differences” among these various modes of communication require translation through “connective cognitive paths” which can ultimately bring about an erroneous conception of the original idea.

It can get complicated. Language of any type may have more limitations for a flawless delivery of meaning among interlocutors than we may be aware of. The philosopher Wittgenstein [3] said “If there did not exist an agreement in what we call ‘red’, etc., language would stop”. At the same time, he raises a more important point

by asking “But what about the agreement in what we call ‘agreement’?”

## 2. Precise and Imprecise Use of Language

Indeed, sometimes, a simple lack of attention to what we have agreed on about the meaning of words and phrases can create controversy, or a fair amount of confusion, within the same—not different—form of linguistic representation. One notable example of this is known as the Monty Hall Problem, also known as “The Monty Hall Dilemma”. The problem was originally conceived in the 1970s. A description of it is provided below [4]:

*A contestant in a game show is given a choice of three doors. Behind one is a car; behind each of the other two, a goat. She selects Door A. However, before the door is opened, the host opens Door C and reveals a goat. He then asks the contestant: “Do you want to switch your choice to Door B?” Is it to the advantage of the contestant (who wants the car) to switch?*

A controversy broke out among career mathematicians and statisticians over whether or not it would be advantageous for the contestant to switch his or her original choice of door. One side in the controversy argued that once the game show host opens one of the doors behind which there is a goat, there will be two closed doors left behind one of which there could be the car, and therefore, there is only a 50/50 “chance” that the contestant will win the car, irrespective of which door he or she stays with.

The other side in the controversy, of course, disagreed with this view. They argued that the contestant's best chance for winning the car was only 1/3 if he/she stayed with the original choice, whereas if the contestant switched from the original choice to the door that the host did not open, the "odds" of winning the car would always increase to 2/3. This latter answer is, of course, the correct answer. One good and clear justification in support of this answer can be given using basic conditional probability. The tree diagrams in **Figures 1** and **2** depict this approach. **Figure 1** shows all possible outcomes for any choice that the contestant and host might make.

Note that Grinstead and Snell [5] use numbers for labeling doors in the tree diagram, whereas Barbean [4] uses English alphabet in his description of the problem.

Now suppose as an example that the contestant chooses door 1 and Monty opens door 2. Given this scenario, only

two path outcomes from **Figure 1** are possible which lead to two *conditionally probable* outcomes. These are shown in the **Figure 2** diagram.

At the beginning of the contest, and before any choice is made by the contestant, the following individual probabilities apply to the car being behind any of the doors, which we will refer to as  $P(D_1)$ ,  $P(D_2)$ , and  $P(D_3)$ .

$$P(D_1)=1/3, \quad P(D_2)=1/3, \quad P(D_3)=1/3 \quad (1)$$

Once the contestant picks door 1 to win, the probability of door  $D_1$  having the car behind it still stands at 1/3, but given this choice by the contestant, the group of two doors  $D_2$  and  $D_3$  now has conditional probability 2/3 of containing the car.

$$P(D_1)=1/3, \quad P(D_2 \cap D_3)=1/3+1/3=2/3 \quad (2)$$

Note that using the language of conditional probability we can easily show that it is always better for the con-

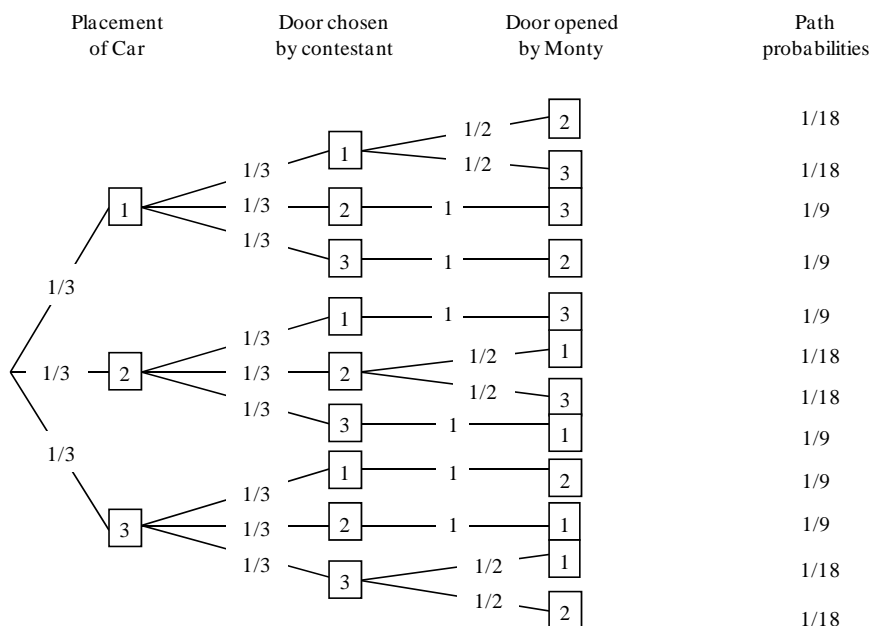

**Figure 1. Tree diagram for the Monty Hall Problem [5].**

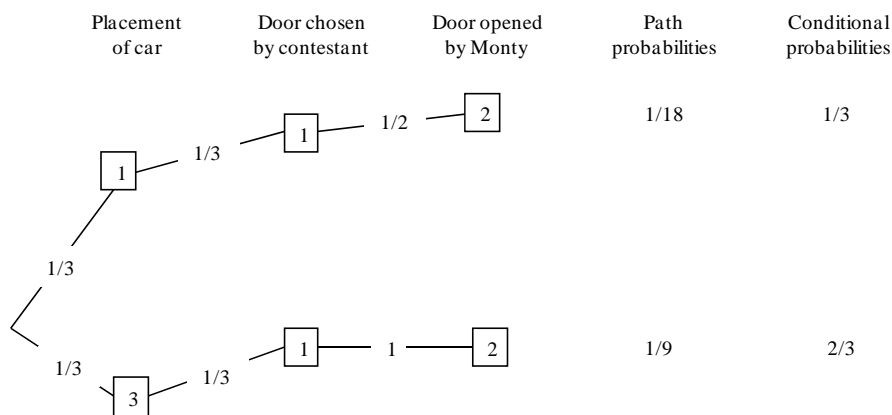

**Figure 2. Tree diagram of conditional probabilities when the contestant chooses door 1 and Monty opens door 2.**

testant to switch from the original selection because by switching, he/she will increase the probability of winning the car by entering the group that has the higher likelihood of containing it. And when the host opens door  $D_2$ , the probability for the entire group will now belong to, and falls under, door  $D_3$ . That is:

$$P(D_3) = P(D_2 \cap D_3) = 2/3 \quad (3)$$

Although the answer to the Monty Hall problem becomes rather obvious using basic conditional probability, this was not the approach by those arguing their case in the controversy over the Monty Hall problem. Both sides in the controversy used much less precise, and sometimes casual language, to state their thinking. Some used the word “probability”, some used the word “odds”, some used the word “chance”, and yet others used a mix of these simultaneously as if all these terms refer to the same thing. But did such an agreement, as Wittgenstein would have probably wondered, exist between the parties to the controversy that all these terms mean the same thing? The possibility of that being the case seems not only remote but also highly unlikely. Hence, faulty reasoning goes undiscovered and communication itself begins to become ineffective—as Wittgenstein had suggested. Consider the following examples of what was said:

Marilyn vos Savant [6], whose answer to the problem agrees with Grinstead and Snell [5], says “Yes; you should switch. The first door has a one-third chance of winning, but the second door has a two-thirds chance.” vos Savant’s use of the casual word “chance” bypasses the clarity of the conditional probabilistic nature of the solution.

vos Savant received many rebuttals with regard to her answer to the Monty Hall Problem. The following two quotations are examples of the responses she received, which were included in her column published in the December 2 issue of *Parade Magazine* [7] that same year:

*You answered, “Yes. The first door has a 1/3 chance of winning, but the second has a 2/3 chance.” Let me explain: if one door is shown to be a loser, that information changes the probability of either remaining choice to 1/2. As a professional mathematician, I’m very concerned with the general public’s lack of mathematical skills. Please help by confessing your error and, in the future, being more careful—Robert Sachs, Ph.D., George Mason University, Fairfax, Va.*

Again, in this rebuttal to vos Savant’s response, the conditional probabilistic nature of the problem has been overlooked. Let’s look at another reply to vos Savant from the same issue of the *Parade Magazine* [7].

*You blew it, and you blew it big! Since you seem to have difficulty grasping the basic principle at work here, I’ll explain: After the host reveals a goat, you now have a*

*one-in-two chance of being correct. There is enough mathematical illiteracy in this country, and we don’t need the world’s highest IQ propagating more. Shame!—Scott Smith, Ph.D., University of Florida.*

In this response, the commentator prefers to use the word “chance” casually as vos Savant herself did, with yet again, the language of conditional probability having been overlooked in the explanation.

Moreover, what is even more interesting is that in her own rebuttal to the rebuttals, vos Savant [7] uses the language of “odds” rather than the language of “chance” which she had initially used:

*Let me explain why your answer is wrong. The winning odds of 1/3 on the first choice can’t go up to 1/2 just because the host opens a losing door. To illustrate this, let’s say we play a shell game. You look away, and I put a pea under one of the three shells. Then I ask you to put your finger on a shell. The odds that your choice contains a pea are 1/3, agreed? Then I simply lift up an empty shell from the remaining two. As I can (and will) do this regardless of what you’ve chosen, we’ve learned nothing to allow us to revise the odds on the shell under your finger.*

This is remarkable! Even though, vos Savant has the right ideas and the answer to the problem, she is not aware of her own inconsistent use of the terms when explaining her own thinking. She uses the word “odds” in the December issue of the magazine, whereas in her response given in the September issue, she uses the word “chance”. Clearly, there does not seem to be an explicit or underlying agreement between the debaters about a single probabilistic concept that could be used as representation of probabilities before and after the host opens a door. No wonder there was confusion and controversy over the correct answer to a simple problem of probabilistic nature. In fact, a cursory look through introductory texts in probability tells us that although “odds” and “probability” are closely related, they are not one and the same concept. Conceptually, they are described as:

$$\begin{aligned} \text{Probability} &= \frac{\text{No. of desired outcomes}}{\text{No. of possible outcomes}}, \\ \text{Odds} &= \frac{\text{No. of desired outcomes}}{\text{No. of undesired outcomes}} \end{aligned} \quad (4)$$

And each can be written in terms of the other as follows [8]:

$$\begin{aligned} \text{Probability} &= \frac{\text{Odds}}{1 + \text{Odds}}, \\ \text{Odds} &= \frac{\text{Probability}}{1 - \text{Probability}} \end{aligned} \quad (5)$$

More formally, if a statement postulates that the odds are  $r$  to  $s$  in favor of an outcome  $E$  occurring, then the probability of the outcome in terms of the given odds

can be given as [5]:

$$P(E) = \frac{r}{r+s} \quad (6)$$

From the different answers provided to the Monty Hall problem by the mathematicians, it is clear that they conceptualized the problem differently. At the same time, a lack of consistent, precise, accurate, and clear use of language of probability seems to have complicated reaching a consensus regarding the solution.

Thankfully, the casual and inconsistent use of probabilistic terms is not unanimous among professionals as there are those who make every effort to avoid vagueness. For example, Matthew Hilger [9], an expert of rules and strategies used in gambling, makes a point of being clear by saying that “Probabilities tell you how frequently an event will happen, odds tell you how many times an event will not happen”. His advice to poker players builds on that distinction. “To determine the odds against improving your hand on the next card,” he writes, “compare the total number of cards that will not help you to the number of cards or ‘outs’ that will.”

To use another example, Charles Darwin [10] was careful when discussing uncertainty in his seminal work, *On the Origin of Species*. He used the word “probability” almost exclusively when discussing adaptation of species over very long periods of time and many hundreds of generations. On the other hand, he used the word “chance” almost exclusively when speaking about survival of species, “profitable variations” within a species, and also when referring to propagation of attributes from parents to their off-spring. Darwin never used the word “odds” in the context of survival or adaptation of species. This demonstrates how careful and conscious he was about applying probabilistic terms to distinguish between short-term and long-term trends in biological evolution.

Similarly, we see the same level of care and deliberate attention in the use of probabilistic language among physicists who dedicate themselves to the study of subatomic particles. The Nobel Prize winner Max Born [11] observed that it was “the concept of *probability* that was applied systematically and built into the system of physics”. Note that he didn’t use the word *odds* or *chance* to make his point. And it was once again another quantum physicist and renowned String Theorist, Brian Greene [12], who wrote “We are accustomed to *probability* showing up in horse races, in coin tosses, and at the roulette table,” he said, “But in those cases it merely reflects our incomplete knowledge.” Once again, note how conscious Greene is about the specific meaning that the term *probability* might take on within various contexts.

The Monty Hall problem presents a far less complicated situation than trying to discern between biological

features that are the result of genetic transmission rather than adaptation of a species over thousands of years, or the situation of trying to predict the most likely location of an electron on the electron wave in quantum mechanics. Do we know for sure that it is only carelessness on the part of professional interlocutors with respect to the use of the probabilistic terms *odds*, *probability*, or *chance* that fueled the controversy over the Monty Hall problem? No. However, it is clear from looking at published arguments from both sides that neither side arguing the case seemed to be aware of the sensitivity of the issue of using the right probabilistic language to make their case.

### 3. Conclusions

As Wittgenstein pointed out, it is the fundamental agreement about the definition of words, which we internalize growing up as a child and into adulthood, that makes language work the way it does. Teachers of mathematics and statistics often use notation to establish a consensus about similarity or difference among concepts when discussing them in writing. For example,  $\mu$  and  $\bar{x}$  are used to distinguish between population and sample means, respectively. Because dissemination of information or exchanging of ideas through spoken and written words is a major part of any form of education, care must be taken to avoid posing dissimilar concepts as similar or vice versa.

The ability to have clarity and deliberate precision in the use of language is a valuable asset and can help alleviate misunderstanding when communicating with others; an asset that great ones like Darwin, Born, and Greene, for example, apparently possessed and made use of in their literary work. But a more significant corollary of this conclusion is that it is even more valid in the classroom environment. More important than what mathematical content we teach is the effort we must put to making concepts clear for our students. This means that as professional teachers, we must keep ourselves humble and flexible, never assuming an infallibility in our own teaching and communication skills.

### REFERENCES

- [1] J. Mestre, “Hispanic and Anglo Students’ Misconceptions in Mathematics,” *ERIC Digest*, 1989.
- [2] K. Abouchedid and R. Nasser, “The Role of Presentation and Response Format in Understanding, Preconceptions and Alternative Concepts in Algebra Problems,” Notre Dame University, Lebanon, 2000.
- [3] L. Wittgenstein, “Remarks on the Foundations of Mathematics,” Revised Edition, MIT Press, Cambridge, 1983.
- [4] E. Barbean, “Fallacies, Flaws, and Flimflam,” *The College Mathematics Journal*, Vol. 24, No. 2, 1993, pp. 149-154.

- [5] C. M. Grinstead and J. L. Snell, "Introduction to Probability," 2nd Edition, American Mathematical Society, Providence, 1998.
- [6] M. vos Savant, "Ask Marilyn Column," *Parade Magazine*, September 2, 1990, p. 14.
- [7] M. vos Savant, "Ask Marilyn Column," *Parade Magazine*, December 2, 1990, p. 28.
- [8] American College of Physicians—American Society of Internal Medicine, "Compendium of Primers," *Effective Clinical Practice*, Vol. 3, No. 3, 2000, p. 2.
- [9] M. Hilger, "Texas Hold'em Odds and Probabilities: Limit, No Limit, and Tournament Strategies," 1st Edition, Dimat Enterprises, Inc., Duluth, 2006.
- [10] C. Darwin, "On the Origin of Species, the Illustrated Edition," Sterling Publishing, New York, 2008.
- [11] M. Born, "Physics in My Generation," Springer-Verlag, New York, 1969.
- [12] B. Greene, "The Elegant Universe: Superstrings, Hidden Dimensions, and the Quest for the Ultimate Theory," W. W. Norton & Company, New York, 2003.