

Energy Harvesting Based on Magnetic Dispersion for Three-Phase Power System

Tarcisio Oliveira de Moraes Júnior, Yuri Percy Molina Rodriguez, Ewerton Cleudson de Sousa Melo, Maraiza Prescila dos Santos, Cleonilson Protásio de Souza

Federal Institute of Paraíba - IFPB, Cajazeiras, Brazil

Department of Electrical Engineering, Federal University of Paraíba - UFPB, João Pessoa, Brazil

Email: tarcisioez@gmail.com, [{molina.rodriguez}](mailto:{molina.rodriguez}@ufpb.br) [{protasio}](mailto:{protasio}@ufpb.br) [{maraiza.santos}](mailto:{maraiza.santos}@ufpb.br) [{ewerton}](mailto:{ewerton}@ufpb.br)

Received 2013

ABSTRACT

This paper presents a comparative study on Magnetic-Dispersion based Energy Harvesting Systems (MD-EHS) on electrical conductors that supply power for a three-phase AC motor. It introduces two MD-EHS which are based on magnetic cores of different material, named, nanocrystalline, ferrite and iron powder. The first one consists of harvesting energy from magnetic flux through three symmetrical magnetic cores installed on each power conductors of a three-phase AC motor. The second one consists of a single magnetic core for harvesting energy from magnetic flux of only one of these conductors. Both ones have an AC/DC converter and a variable resistor based load. Experimental results have agreed with the theoretical analysis and show that the first proposed MD-EHS is capable of supplying 14 times more energy than the second MD-EHS, considering nanocrystalline cores and phase current of 3 A, and 7.5 times more energy, considering ferrite cores and phase current of 9 A. Such energy can be applied to various low-power devices, especially in wireless sensor network.

Keywords: Energy Harvesting; Magnetic Dispersion; Magnetic Cores

1. Introduction

Energy Harvesting is the process of capturing small amounts of energy from energy sources available in environment, for instance: thermal, solar, mechanical, magnetic induction, and others, and it is specially applied in supplying energy to low-power devices particularly those from wireless sensor networks. Energy harvesting system based on magnetic induction is receiving considerable attention since it is also applicable in measuring variable in power lines.

An example of application of energy harvesting by magnetic induction can be seen in [1] in which a system composed basically of a magnetic flux device is capable of transmitting to a base station the values of temperature variations of the power line where itself is installed. In [2] is proposed a system to harvest energy from electrostatic field created between a power line and the ground. Experimental results have shown that the system can harvest 16 mW. In [3] was studied an energy harvester based on magnetic induction on power line using a simple circuit model to validate the obtained theoretical results. As a result, 1mW of power was achieved considering air-core and 6.32 mW considering an iron core from a magnetic field of 21.2 uT. Recently, in [4] it was stud-

ied a tube shaped energy harvester from power lines where the power conditioning circuit is constraint for constant voltage. As a result, the circuit efficiency does influence the level of its output voltage. For constant output power, the voltage level of the power conditioning circuit decreases while the voltage of the transmission line increases.

In this work, it is presented a comparative study on Magnetic-Dispersion based Energy Harvesting Systems (MD-EHS) on electrical conductors that supply power for a three-phase AC motor. It was developed two MD-EHS's which are based on magnetic cores of different material, named, nanocrystalline, ferrite and iron powder. The first one, called 3F-MD-EHS, consists of harvesting energy from magnetic flux through three symmetrical magnetic cores installed on each power conductors of a three-phase AC motor. The second one, called 1F-MD-EHS, consists of a single magnetic core for harvesting energy from magnetic flux of only one of these conductors.

This work is organized as follows: Section II describes the essential theory of magnetic field regarding the cores specifications, Section III shows the experimental analysis, Section IV, the experimental results, and Section V, the main conclusions.

2. Magnetic Field Theory

According to Ampere's law, the magnetic flux density at a given distance r from a infinitely long conductor carrying an alternating current with a peak amplitude I and frequency ω is given by:

$$B = \frac{\mu_m I \sin(\omega t)}{2\pi r} \quad (1)$$

where B is the magnetic flux density in a distance r of the conductor and μ_m is the magnetic permeability of the material between the conductor and the point r .

Figure 1 shows a laminated core on the power conductor in a transversal way which the proposed MD-EHS's are based on. This core provides the magnetic path for the magnetic flux and consists of about 50 thin strips that are electrically separated by a thin layer of insulating material. A coin, not shown in the figure, is on the laminated core and is where the induced voltage takes place.

Based on **Figure 1**, the concatenated magnetic flux, ϕ , across the laminated core, with sectional area A , is given by:

$$\phi = \int BdA \quad (2)$$

where

$$dA = wdr \quad (3)$$

Substituting (1) and (3) in (2), it is obtained:

$$\phi_L = \frac{\mu_m I \sin(\omega t)}{2\pi} w \int_{r_L}^{r_f} \frac{dr}{r} \quad (4)$$

which can be reduced as follows:

$$\phi_L = \frac{\mu_m I \sin(\omega t) w}{2\pi} \ln \left(\frac{r_L + h}{r_L} \right) \quad (5)$$

where ϕ_L : magnetic flux of the magnetic L -th strip of the core (where $0 < L < N_L$, N_L = number of core strips)

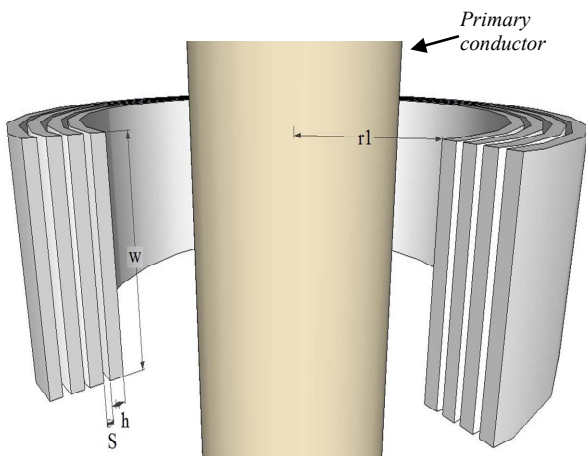

Figure 1. Laminated core on a power conductor.

and r_L is the radius of the L -th strip.

Concern the magnetic flux into the insulating material between the laminated core strips, it is obtained from a similar way and it is obtained:

$$\phi_P = \frac{\mu_0 I \sin(\omega t) w}{2\pi} \ln \left(\frac{r_P + S}{r_P} \right) \quad (6)$$

where ϕ_P : magnetic flux of the magnetic P -th strip of the core (where $0 < P < N_{L-1}$) and r_P is the radius of the P -th strip.

Considering now that is a coin wounds around the core with N_2 turns. In this way, the output voltage of coin terminals, according to Faraday's Law, is expressed as:

$$V_S = -N_2 \frac{d\phi_T}{dt} \quad (7)$$

where ϕ_T is the total magnetic flux. ϕ_T can be obtained by the summation of the magnetic flux through the magnetic and insulating blades:

$$\frac{d\phi_T}{dt} = \sum_{L=1}^{L=n} \frac{d\phi_L}{dt} + \sum_{P=1}^{P=n-1} \frac{d\phi_P}{dt} \quad (8)$$

where:

$$\frac{d\phi_L}{dt} = \frac{\mu_m I \omega \cos(\omega t) w}{2\pi} \ln \left(\frac{r_L + h}{r_L} \right) \quad (9)$$

$$\frac{d\phi_P}{dt} = \frac{\mu_0 I \omega \cos(\omega t) w}{2\pi} \ln \left(\frac{r_P + S}{r_P} \right) \quad (10)$$

To obtain theoretical results, it was considered as parameters the core dimensions: w , h , S , and r_1 (internal radius), as shown in **Figure 1**.

3. Experimental Study

In order to design the proposed MD-EHS, it was used magnetic cores of three different materials: iron powder, ferrite and nanocrystalline. The first proposed MD-EHS, called 3F-MD-EHS, consists of harvesting energy from magnetic flux through three symmetrical magnetic cores installed on each power conductors of a direct start three-phase AC motor, as can be seen in **Figure 2**.

In **Figure 3**, it is shown the power conditioning circuits (PCC) for the 3F-MD-EHS and in **Figure 4** it is shown for the 1F-MD-EHS.

The second proposed MD-EHS, called 1F-MD-EHS, consists of a single magnetic core for harvesting energy from magnetic flux of only one of these conductors.

It was carried out several experiments considering cores of iron powder, ferrite and nanocrystalline and load values, R_v , ranging from 10 Ω up to 10 k Ω . In all experiments, the phase current of each conductor is 3 A for the nanocrystalline cores, 9 A for ferrite and 12 A for iron powder. The main parameters of the used cores are described in **Table 1**.

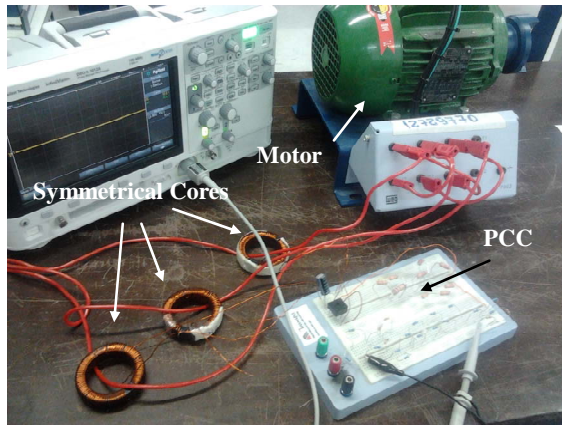

Figure 2. 3F-MD-EHS.

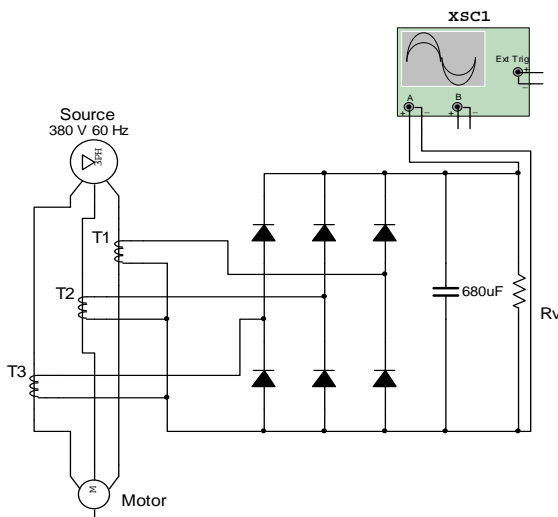

Figure 3. Power conditioning circuit of the 3F-MD-EHS.

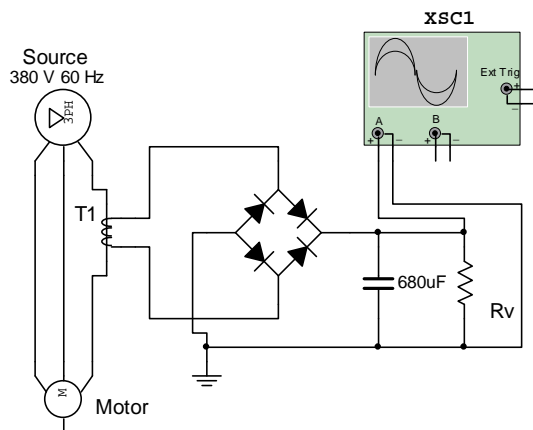

Figure 4. Power conditioning circuit of the 1F-MD-EHS.

4. Experimental Results

After performing experiments considering the different cores and the set of values of R_v , it was possible to obtain the maximum obtained power and the voltages values.

The best results are described in **Tables 2** and **3** and the results considering the variations of R_v can be seen in **Figure 5** for the 3F-MD-EHS and **Figure 6** for the 1F-MD-EHS showing the power obtained for each value of the load, R_v .

Table 1. Parameters of the used cores.

Material	Core's Parameters				
	w [mm]	h [mm]	r [mm]	S	μ_r
Ferrite	8	4.2	6.85	0.0006	2300
Nanocrystalline	10.35	4.4	22.5	0.0006	1000000
Iron Powder	18	11.3	12.05	0.0006	75

Table 2. Experimental results from 3F-MD-EHS.

Material	3F-MD-EHS				
	V [mV]	I [mA]	P [mW]	R_v [Ω]	I_p [Arms]
Ferrite	560	11.3	6.3	50	3.0
Nanocrystalline	374	37.4	14	10	9.0
Iron Powder	5.7	0.57	0.0032	10	12.0

Table 3. Experimental results from 1F-MD-EHS.

Material	1F-MD-EHS				
	V [mV]	I [mA]	P [mW]	R_v [Ω]	I_p [Arms]
Ferrite	310	4.6	1.5	70	3.0
Nanocrystalline	602	1.5	0.9	400	9.0
Iron Powder	18.5	1.85	0.034	10	12.0

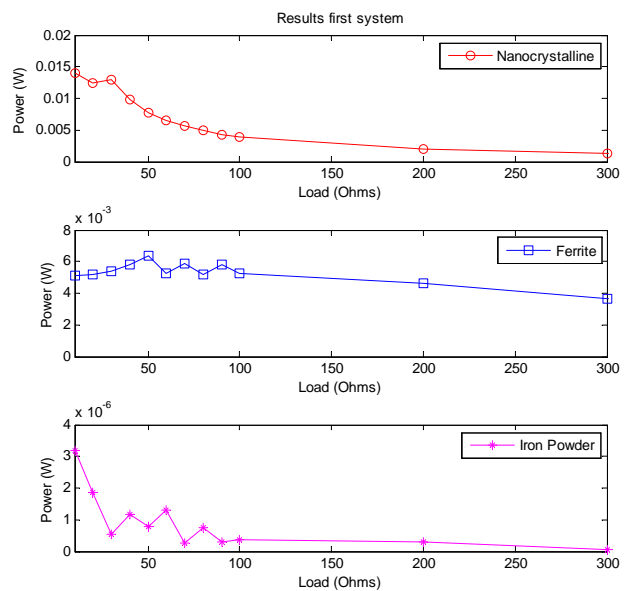

Figure 5. Power levels – first system.

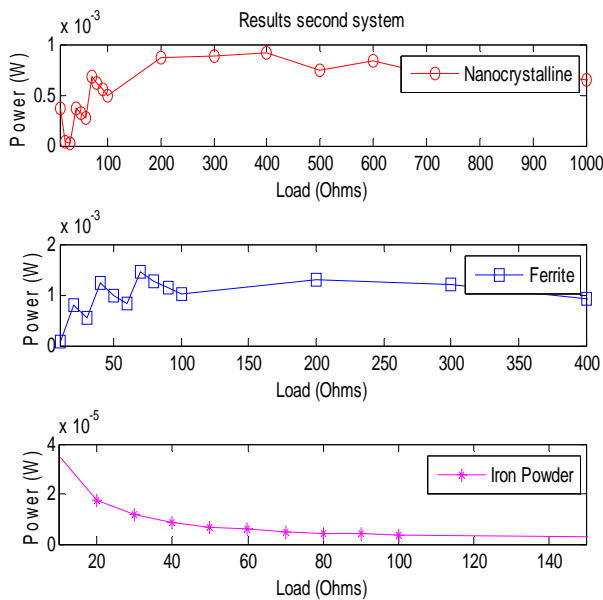

Figure 6. Power levels – second system.

5. Conclusions

In this work, it was presented two proposed Magnetic-Dispersion based Energy Harvesting Systems, called 3F-MD-EHS and 1F-MD-EHS, where the former works on three phase conductors and the latter on one phase conductor. Both are based on magnetic cores of different material, named, nanocrystalline, ferrite and iron powder. The obtained experimental results have shown that, considering the 3F-MD-EHS, it was capable of harvesting up to 14 mW at a load of 10 Ω for a nanocrystalline core with 3 A RMS current on the power line; up to 6.3 mW at a load of 50 Ω for a ferrite cores with 9 A RMS current on the power line; and up to 3.2 μ W at a load of 10 Ω for

a core of iron powder with 12 A RMS current. Considering the 1F-MD-EHS, it was capable of harvesting up to 0.9 mW at a load of 400 Ω for the nanocrystalline core with 3 A RMS current on the power line; up to 1.5 mW at a load of 70 Ω for ferrite cores with 9 A RMS current on the power line, and up to 34 μ W for a load of 10 Ω for an iron powder core with 12 A current on the power line. In this way, it can be observed that the power harvested from the nanocrystalline core 3F-MD-EHS is 14 times higher than the nanocrystalline core 1F-MD-EHS and 7.5 times higher considering ferrite core. However, considering iron powder cores, the obtained power of the 3F-MD-EHS was 10 times less than in the 1F-MD-EHS.

REFERENCES

- [1] D. M. Toma, J. Del Rio and A. M. Lázaro, "Self-Powered High-Rate Wireless Sensor Network for Underground High Voltage Power Lines," *Instrumentation and Measurement Technology Conference*, p. c1, 2012.
- [2] X. Zhao, M. Ketuel, M. Baldauf and O. Kanaoun, "Energy harvesting for overhead power line monitoring," *Systems, Signals and Devices (SSD), International Multi-Conference on*, 2012, pp. 1-5.
- [3] K. Tashiro, H. Wakiwaka, S. Inoue and Y. Uchiyama, "Energy Harvesting of Magnetic Power-Line Noise," *IEEE Transactions on Magnetics*, Vol. 47, No.10, 2011, pp. 4441-4444.
doi.org/10.1109/TMAG.2011.2158190
- [4] F. Guo, H. Hayat and J. Wang, "Energy Harvesting Devices for High Voltage Transmission Line Monitoring," *Power and Energy Society General Meeting, IEEE*, 2011, pp. 1-8.