

Realizations of Voltage Transfer Functions Using DVCCs

Tejmal S. Rathore

School of Electrical Sciences, IIT Goa, Ponda, India

Email: tsrathor@ee.iitb.ac.in, tsrathore@iitgoa.ac.in

How to cite this paper: Rathore, T.S. (2018) Realizations of Voltage Transfer Functions Using DVCCs. *Circuits and Systems*, 9, 141-147.

<https://doi.org/10.4236/cs.2018.910015>

Received: July 30, 2018

Accepted: October 27, 2018

Published: October 31, 2018

Copyright © 2018 by author and Scientific Research Publishing Inc.

This work is licensed under the Creative Commons Attribution International License (CC BY 4.0).

<http://creativecommons.org/licenses/by/4.0/>



Open Access

Abstract

Maheshwari has proposed three differential-voltage current-conveyor configurations for realizing *first order all-pass filters* only. This paper has exploited these configurations for realizing *more complex transfer function* $T(s)$ which yield poles and zeros of $1 - T(s)$ in one of the four admissible patterns. Bilinear and biquadratic functions are dealt in detail. It is shown that only bilinear functions can be realized with all the four passive elements grounded. First order all-pass function is a special case which needs only three elements ($2R, 1C$) or ($1R, 2C$). A biquadratic function requires ($2R, 2C$) elements and has all the capacitor grounded. Design of second order all-pass function is given.

Keywords

Differential-Voltage Current-Conveyor, All-Pass Filters, Bilinear Functions, Biquadratic Functions

1. Introduction

The symbol of a difference voltage current conveyor (DVCC) is shown in **Figure 1** and its characteristics are summarized by the following port relationships [1]

$$V_X = V_{Y1} - V_{Y2}, I_{Y1} = I_{Y2} = 0, I_{Z+} = I_X, I_{Z-} = -I_X \quad (1)$$

Maheshwari [2] has proposed three configurations, shown in **Figure 2**, using DVCC for realizing only *first order voltage-mode all-pass filter*. The filter has the advantages of high input resistance and minimum number of RC elements and all of them grounded.

The intent of this paper is to exploit the circuit topologies of **Figure 2** to realize *more general class of functions*. Conditions of realization are derived. Then we consider realizations of *bilinear* and *biquadratic* functions in detail. In the

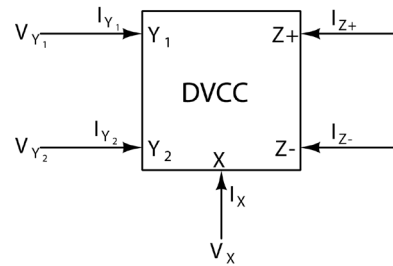

Figure 1. Block representation of a differential voltage current conveyor.

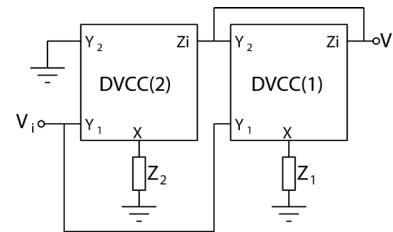

Figure 2. Proposed topologies where z_i 's in DVCC (1) and (2) are (a) z_+ , z_- ; (b) z_- , z_+ , (c) z_+ , z_+ , respectively.

former case, it is shown that only first order functions can have all passive components grounded, and that there are only two possible cases with minimum number of passive elements ($1C\ 2R$ and $2C\ 1R$) logically, rather than intuitionally in [2]. In case of biquadratic function only 4 passive elements ($2C, 2R$) are required with both the capacitors grounded. Design of a second order all-pass function is given.

2. Realization of a General Voltage Transfer Function

Each of the circuit topologies of **Figures 2(a)-(c)** has the voltage transfer function

$$T(s) = K \frac{N(s)}{D(s)} = 1 - Z_1 Y_2 \tag{2}$$

From (2),

$$Z_1 Y_2 = \frac{D(s) - KN(s)}{D(s)}. \tag{3}$$

Note that the poles of $Z_1 Y_2$ are the same as those of T ; but zeros are given by $D - KN = 0$. Impedances Z_1 and Z_2 can be identified as RC driving point functions (DPIs) from (3), if the poles and zeros of $Z_1 Y_2$, arranged in pairs starting from the rightmost pair, each pair consists of a pole and a zero in either order [3]. The four admissible pole-zero patterns are shown in **Figure 3**. $T(s)$, so also $Z_1 Y_2$, must have poles distinct negative real. Zero lociof $Z_1 Y_2$ start from the poles when $K = 0$ and terminate on the zeros of $T(s)$ when $K = \infty$. Hence it is possible to choose K sufficiently small so that the zeros are negative real. Thus, if the poles and zeros of $Z_1 Y_2$ fit into one of the patterns shown in **Figure 3**, T is realizable otherwise not.

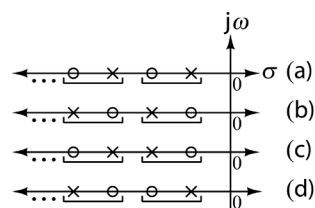

Figure 3. Admissible pole zero patterns.

2.1. Realization of Bilinear Voltage Transfer Functions

Let the bilinear voltage transfer function be

$$T(s) = \frac{K(s+z)}{s+p} = 1 - Z_1 Y_2 \quad (4)$$

If z is positive, i.e., it lies on the negative real axis, then $T(s)$ can be realized by RC passive elements. Therefore, we shall consider the case when z is negative i.e., $0 \leq z \leq \infty$.

Then

$$Z_1 Y_2 = \frac{(1-K)s + (p + Kz)}{s+p}. \quad (5)$$

The zero-locus with K as variable is shown in **Figure 4**. It starts from pole at $-p$ when $K = 0$ and reaches $-\infty$ when $K = 1$ and again from $+\infty$ to zero at z from $K = 1$ to $K = \infty$. Thus choosing $0 < K \leq 1$, the zero of $Z_1 Y_2$ can be made negative real. Thus it will follow the pattern shown in **Figure 3(a)** and **Figure 3(d)**. Now

$$Z_1 Y_2 = \mu \frac{s + \alpha}{s + p}, \quad p < \alpha \leq \infty. \quad (6)$$

Only possible identifications are

$$Z_1 = \frac{\mu_1}{s+p}, \quad Y_2 = \mu_2 (s + \alpha) \quad (7)$$

$$Z_1 = \mu_1 \frac{s + \alpha}{s}, \quad Y_2 = \mu_2 \frac{s}{s+p} \quad (8)$$

$$Z_1 = \mu_1 \frac{s + \alpha}{s+p}, \quad Y_2 = \mu_2 \quad (9)$$

where $\mu = \mu_1 \mu_2$. The possible canonic realizations of Z_1 and Z_2 in Foster and Cauer forms from (7) is given in **Figure 5(a)**, from (8) in **Figure 5(b)**, and from (9) in **Figure 5(c)** and **Figure 5(d)**, respectively.

Minimum 4 elements (2C, 2R) or (1C, 3R) are required for realizing $Z_{1,2}$ as shown in **Figure 5**. However, one element can be reduced by choosing $K = 1$ which forces the zero of $Z_1 Y_2$ at ∞ (see (5)). The reduced realizations of $Z_{1,2}$ are shown in **Figure 6**. The complete realizations of $T(s)$ given by (4) is obtained by inserting $Z_{1,2}$ of **Figure 6** in **Figure 2**. They reduce to all-pass functions when $p = z$. Thus we get (2R, 1C) and (1R, 2C) realizations for first order all-pass function. The realization corresponding to (2R, 1C) has all the passive elements grounded. We have thus shown that there are four possible realizations and only one of

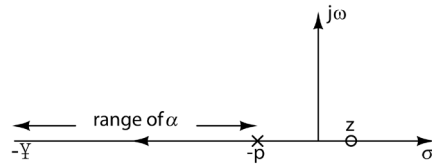

Figure 4. Root locus with K as variable.

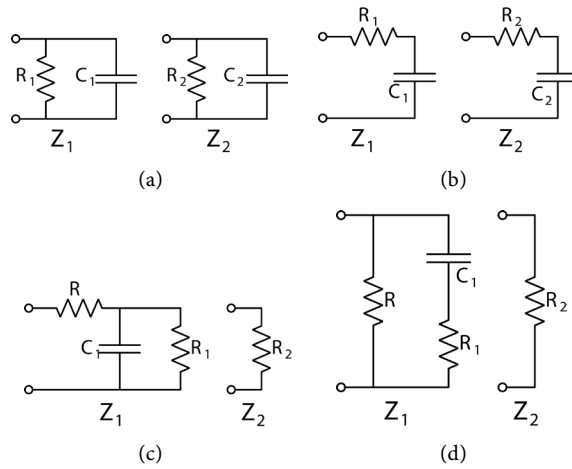

Figure 5. Realizations of Z_1 and Z_2 given by (a) (7); (b) (8) and (c) and (d) by (9).

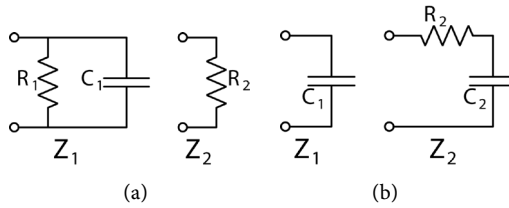

Figure 6. Two realizations of $Z_{1,2}$.

which have all three elements ($2R, 1C$) grounded systematically, and not intuitively as in [2].

Alternative proof

In Figure 2, Z_1 and Z_2 can have only one R and one C element at the most in parallel for them to be grounded. Any additional resistance (capacitance) in parallel will be absorbed in R (C) already present. Let Z_i ($i = 1, 2$) be parallel combinations of one R_i and one C_i as shown in the Figure 5(d). Then

$$Z_i = \left(\frac{1}{C_i} \right) \frac{1}{\left(s + \frac{1}{C_i R_i} \right)}, \quad i = 1, 2 \tag{10}$$

Now

$$T(s) = 1 - \frac{Z_1}{Z_2} = \left(1 - \frac{C_2}{C_1} \right) \frac{s - \frac{1}{\left(1 - \frac{C_2}{C_1} \right)} \left(\frac{R_1}{R_2} - 1 \right) \frac{1}{C_1 R_1}}{\left\{ s + \frac{1}{C_1 R_1} \right\}} = \mu \frac{\{s - \alpha\}}{\{s + p\}} \tag{11}$$

Since the denominator is of first order, the circuit can realize only bilinear transfer functions with four components ($2C$ and $2R$); all grounded. The number of elements can be reduced by 1 under specific conditions. Let us consider the special case of all pass function. From (11), the condition is

$$Z_i = \left(\frac{1}{C_i} \right) \left(\frac{1}{s + \frac{1}{C_i R_i}} \right), \quad i = 1, 2 \quad (12)$$

There are infinite number of solutions to satisfy (11). From (11), it is obvious that R_1 cannot be equal to R_2 and C_1 cannot be equal to C_2 . To have minimum number of passive components, the choices are $C_2 = 0$, $R_1 = 2R_2$ and $R_2 = \infty$, $C_2 = 2C_1$. In the latter choice, it can be seen from (11) that $T(s)$ will be negative. These choices were directly chosen in [2] without any logic.

2.2. Realization of Biquadratic Transfer Functions

Let the function be expressed as

$$T(s) = K \frac{(s + z_1)(s + z_2)}{(s + p_1)(s + p_2)} \quad (13)$$

where poles $p_{1,2}$, as discussed above, have to be negative real and $z_{1,2}$ may lie anywhere in the s -plane. Then from (2)

$$Z_1 Y_2 = \frac{(1-K)s^2 + [(p_1 + p_2) - K(z_1 + z_2)]s + (p_1 p_2 - K z_1 z_2)}{(s + p_1)(s + p_2)} \quad (14)$$

To realize with minimum number of elements, we choose $K = 1$. Then

$$Z_1 Y_2 = \frac{[(p_1 + p_2) - (z_1 + z_2)]s + (p_1 p_2 - z_1 z_2)}{(s + p_1)(s + p_2)} = \mu \frac{(s + \alpha)}{(s + p_1)(s + p_2)} \quad (15)$$

where $\mu = (p_1 + p_2) - (z_1 + z_2)$ and $\alpha = \frac{p_1 p_2 - z_1 z_2}{(p_1 + p_2) - (z_1 + z_2)}$. If α and $p_{1,2}$

satisfy any of the pole-zero patterns shown in **Figure 3** then $Z_{1,2}$ can be identified as driving point impedances. Since there are many possible locations of $z_{1,2}$, we explain the procedure by taking the all-pass function for which $z_{1,2} = -p_{1,2}$. Then (15) reduces to

$$Z_1 Y_2 = \mu \frac{s}{(s + p_1)(s + p_2)} \quad (16)$$

where $\mu = 2(p_1 + p_2)$.

Now $Z_{1,2}$ can be identified, in two possible ways as

$$Z_1 = \frac{\mu_1}{s + p_{1,2}}, \quad Z_2 = \frac{s + p_{2,1}}{\mu_2 s} \quad (17)$$

where $\mu = \mu_1 \mu_2$.

Choosing $\mu_1 = \mu_2 = 1$, Two realizations of $Z_{1,2}$ given by (17) are shown in **Figure 7**. As expected, all elements are not grounded. It is interesting to realize an all-pass filter with double poles, *i.e.*, $p_1 = p_2 = p$. In this case (17) reduces to

$$Z_1 = \frac{\mu_1}{s+p}, \quad Z_2 = \frac{s+p}{\mu_2 s} \tag{18}$$

Example: Realize a second order all-pass function

$$T(s) = \frac{s^2 - 4s + 3}{s^2 + 4s + 3} \tag{19}$$

Here

$$Z_1 Y_2 = 1 - T(s) = \frac{8s}{(s+1)(s+3)} \tag{20}$$

Identifying

$$Z_1 = \frac{1}{s+1}, \quad Z_2 = \frac{s+3}{8s} \tag{21}$$

the complete realization of $T(s)$ of (19) is given in **Figure 8**.

3. Conclusion

Maheshwari [1] proposed three DVCC configurations and used them for realizing only *first order all-pass filters*. This paper has exploited these configurations for realizing transfer function $T(s)$ such that the location of poles and zeros of $1 - T(s)$ matches with any one shown in **Figure 3**. It has been proved that only bilinear functions can be realized with all the four passive elements grounded. First order all-pass function is a special case which needs only three elements (2R, 1C) or (1R, 2C). Biquadratic functions have also been considered. They require (2C, 2R) passive elements with both the capacitors grounded. We have not attempted here the non-ideal analysis, simulation and applications as they are very well documented in [1].

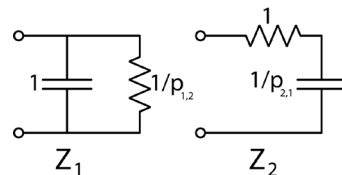

Figure 7. Two realizations of $Z_{1,2}$ given by (17).

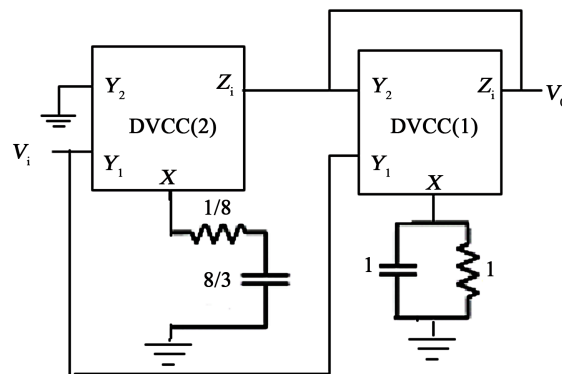

Figure 8. Realization of all pass function given by (19).

Conflicts of Interest

The author declares no conflicts of interest regarding the publication of this paper.

References

- [1] Ibrahim, M.A., Minaei, S. and Kuntman, H. (2005) A 22.5 MHz Biquad Using Differential Voltage Current Conveyor and Grounded Passive Elements. *International Journal of Electronics and Communications*, **59**, 311-318.
- [2] Maheshwari, S. (2007) High Input Impedance VM-APs with Grounded Passive Elements. *IET Circuits, Devices and Systems*, **1**, 72-78.
<https://doi.org/10.1049/iet-cds:20060196>
- [3] Rathore, T.S. and Khot, U.P. (2005) Single FTFN Realization of Current Transfer Functions. *IETE Journal of Research*, **51**, 193-199.
<https://doi.org/10.1080/03772063.2005.11416395>