

Thermodynamical Phase Noise in Oscillators Based on L - C Resonators*

Javier Malo, Jose-Ignacio Izpura

Group of Microsystems and Electronic Materials (GMME-CEMDATIC), Universidad Politécnica de Madrid (UPM), Madrid, Spain
Email: jmalo@sec.upm.es

Received September 19, 2011; revised October 19, 2011; accepted October 27, 2011

ABSTRACT

Using a new Admittance-based model for electrical noise able to handle Fluctuations and Dissipations of electrical energy, we explain the phase noise of oscillators that use feedback around L - C resonators. We show that Fluctuations produce the Line Broadening of their output spectrum around its mean frequency f_0 and that the Pedestal of phase noise far from f_0 comes from Dissipations modified by the feedback electronics. The charge noise power $4FkT/R$ C^2/s that disturbs the otherwise periodic fluctuation of charge these oscillators aim to sustain in their L - C - R resonator, is what creates their phase noise proportional to Leeson's noise figure F and to the charge noise power $4kT/R$ C^2/s of their capacitance C that today's modelling would consider as the current noise density in A^2/Hz of their resistance R . Linked with this ($A^2/Hz \leftrightarrow C^2/s$) equivalence, R becomes a random series in time of discrete chances to Dissipate energy in Thermal Equilibrium (TE) giving a similar series of discrete Conversions of electrical energy into heat when the resonator is out of TE due to the Signal power it handles. Therefore, phase noise reflects the way oscillators sense thermal exchanges of energy with their environment.

Keywords: Phase Noise; Admittance-Based Noise Model; Fluctuation; Dissipation; Conversion into Heat

1. Introduction

In a previous paper under this title [1] we have shown that when a Positive Feedback (PF) building a voltage in a capacitor is counterbalanced by a Negative Feedback (NF) we called Clamping Feedback (CF), to keep such voltage close to a reference V_{Ref} , a Pedestal of electrical noise was generated. This Pedestal of 50% the amplitude of the native noise but wider bandwidth was due to the confusing action of the 50% noise the CF samples in quadrature with the carrier whose amplitude it aims to sustain in time. This is so because the CF implicit in the Automatic Level Control (ALC) systems or limiters of actual oscillators is phase-locked to the carrier whose amplitude it has to keep in time. This subtle effect was shown in a convenient resonator of $f_0 \rightarrow 0$, which was a capacitor of capacitance C shunted by a resistance R to account for its losses. Accordingly to [2], losses due to a conductance $G = 1/R$ are a random series of discrete opportunities in time to Dissipate electrical energy in Thermal Equilibrium (TE) and to Convert it into heat out of TE [1]. This resonator was used to build an "oscillator of $f_0 \rightarrow 0$ " where it was easy to show that the ampli-

tude the CF keeps at each instant is the sum of V_{Ref} plus a small amplitude offset $v_\varepsilon \ll V_{Ref}$ that is the error signal driving the CF towards its goal: to counterbalance the excess of PF used during the start of the oscillator. When this counterbalance was achieved, this oscillator of $f_0 \rightarrow 0$ sustained a voltage $V_0 = V_{Ref} + v_\varepsilon(t) \approx V_{Ref}$ where $v_\varepsilon(t)$ was a constant average value $\langle v_\varepsilon(t) \rangle$ plus electrical noise superposed to it. The reference $V_{Ref}(t_n)$ that the CF needs at instant n to clamp the output amplitude was available from the reference $V_{Ref}(t_{n-1})$ at instant $n-1$ because $V_{Ref}(t_n) = V_{Ref}(t_{n-1})$ in this "convenient oscillator". This availability of $V_{Ref}(t_n)$, which is not possible when $f_0 \neq 0$ because it would require having in advance an electrical reference of the signal the oscillator is going to create, allowed us to show the origin of the aforesaid Pedestal of electrical noise of amplitude $2FkTR$ V^2/Hz . Whereas the 50% of noise power sampled in phase by the CF was heavily damped as expected, the 50% noise power sampled in quadrature (e.g. "midway" 0° for NF and 180° for PF) was enhanced by the CF and gave the aforesaid Pedestal. As we advanced in [1], a similar reasoning for $f_0 \neq 0$ would require a sinusoidal reference $V_{Ref}(t)$ whose generation in advance (e.g. just before to be used) didn't help to explain the noise Pedestal, whence it can be seen the usefulness of the "resonator

*Work supported by the Spanish CICYT under the MAT2010-18933 project, by the Comunidad Autónoma de Madrid through its IV-PRICIT Program, and by the European Regional Development Fund (FEDER).

of $f_0 \rightarrow 0$ ” we handled in [1] for this purpose.

Shunting the R - C parallel circuit of a capacitor with a finite inductance $L \neq 0$ one gets an L - C - R parallel resonator whose resonance frequency $f_0 \neq 0$ allows oscillators repeating phase each $T_0 = 1/f_0$ seconds. Actually, this repetition exactly each T_0 seconds is impossible, thus meaning that the spectrum of their output signal won't give a “line” or $\delta(f - f_0)$ function. Instead, it will have a non null width due to the charge noise existing in the resonator at temperature T , as we will show. This noise coming from the charge noise of the lossy resonator and from the noise added by the electronics, both collected by Leeson through an effective noise figure F [3], has a power $4FkT/R$ C^2/s [2]. This charge noise disturbing the otherwise periodic charge fluctuation of the lossless L - C resonator, not only justifies Leeson's empirical formula, but also explains the non null width (Line Broadening) of the output spectrum of this type of oscillators [4]. This is possible because the new model [2] not only considers *Dissipations* of electrical energy, but also *Fluctuations* of electrical energy in C that precede the former ones in an electrical Admittance.

Before handling resonators with $f_0 \neq 0$, let's recall that to sustain the amplitude of their output signal $v(t)$ in time endures to sample $v(t)$ each T_0 seconds and the ALC system or limiter will react from this set of sampled data. Due to the phase noise (jitter in time domain) of the own amplitude thus generated, this sampling won't be done *exactly* each T_0 (or each $T_0/2$ seconds by sampling positive and negative peaks), although we will consider it as fast and accurate enough to allow the ALC system to handle properly amplitude changes with spectral content up to $f_0/2$ or up to f_0 by sampling each $T_0/2$, accordingly to Nyquist sampling theorem. The high speed this sampling rate could provide to the ALC system is not used in general because amplitude changes endure energy ones in the resonator. Since the quality factor Q_0 of an L - C - R resonator at its resonance frequency is: “ π times the lifetime of its output voltage $v(t)$ measured in periods T_0 ”, amplitude changes during one period in high- Q resonators will be small. Thus, the aforesaid sampling rate will work well for quartz resonators like that of [3], where Q_0 factors over 10^4 are often found. This allows considering that the CF associated to the ALC system or limiter works as expected and since these electromechanical resonators use to be studied by highly selective L - C - R circuits, our results can be applied to them easily.

2. Dissipation and Feedback-Induced Noise in an L - C - R Resonator

It's well known that the sinusoidal voltage and current existing at any frequency f in an electrical Susceptance are *in-quadrature*. To work in parallel mode let's use the

Admittance function of frequency $f = \omega/2\pi$ whose real part is Conductance $G(j\omega)$ and whose imaginary part is Susceptance $B(j\omega)$: $Y(j\omega) = G(j\omega) + jB(j\omega)$, where the imaginary unit j means that currents through $G(j\omega)$ and those through $B(j\omega)$ are in-quadrature. Considering a sinusoidal voltage existing between the two terminals of $Y(j\omega)$, currents through $B(j\omega)$ allow Fluctuations of electrical energy in $Y(j\omega)$ whereas those through $G(j\omega)$ lead to Dissipations of electrical energy [2]. This is the basis of the new model for electrical noise we will use for L - C - R resonators that agreeing with [5], is thus a Quantum-compliant model leading us to consider *Fluctuations* of electrical energy in the Susceptance of these resonators together with *Dissipations* of electrical energy associated to their Conductance $G = 1/R$.

Figure 1(a) shows an L - C - R parallel resonator with losses proportional to the energy stored in C at each instant $U_E(t) = Cv^2(t)/2$ because $p_i(t) = v^2(t)/R$ is the instantaneous power lost in R . Thus, the energy stored in magnetic form does not produce losses in this resonator. Although these losses represented by R may be due to a resistance R_S in series with the inductance L_S of an inductor shunting C , the circuit transform leading to the circuit of **Figure 1(a)** makes them equivalent to those of a lossy capacitor shunted by the lossless inductance L .

A native L_S - C - R_S series resonator is thus replaced by its parallel equivalent circuit of **Figure 1(a)** to use directly the new model of [2] for the electrical noise of the Ad-

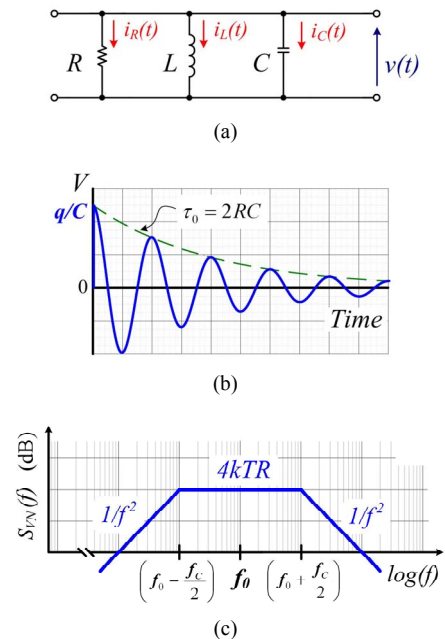

Figure 1. (a) L - C resonator with losses proportional to the energy stored in C at each instant; (b) Impulse response of this L - C resonator to a charge Fluctuation of one electron; (c) Unilateral spectrum of $v(t)$ (see text).

mittance formed by C and R in parallel. This noise comes from a random series of Thermal Actions (TA) that occur in C at an average rate λ_T (TAs per second), given by [2]:

$$\lambda_T = \frac{2kT}{Rq^2} \Rightarrow G = \frac{1}{R} = \lambda_T \frac{q}{2V_T} \quad (1)$$

where q is the electronic charge and $V_T = kT/q$ is the thermal voltage at Temperature T .

Each TA triggers a Device Reaction (DR) aiming to remove the previous Fluctuation of energy in C due to the TA. The use of the parallel circuit of **Figure 1(a)**, whose noise will come from *Fluctuations of electrical energy*, has to do with the Cause-Effect or TA-DR pairs producing electrical noise in resistors and capacitors [2], where each TA is a charge noise of one electron. This TA or impulsive displacement current of weight q in C creates a voltage step $\Delta v = q/C$ V in C and thus in $v(t)$. **Figure 1(b)** shows the time evolution of $\Delta v(t)$ after a TA on C discharged previously, thus showing the DR of this lossy $L-C$ resonator. This DR is a damped oscillation of angular frequency $\omega_0 = (LC)^{-1/2}$ rad/s and initial amplitude q/C V that can be built from the product of the exponential decay of **Figure 1(b)** of [1] with amplitude $V_0 = q/C$, by a cosine carrier of frequency f_0 . Since these random DRs occur in time at the average rate λ_T of (1), the spectral content of the noise they will give will be like that of Figure 8(a) of [1], but around f_0 and with half its bandwidth due to the two times larger time constant ($2RC$) of **Figure 1(b)**. This is the noise spectrum of the $L-C-R$ resonator without feedback shown in **Figure 1(c)**, that will differ from the noise spectrum under the action of the Positive (PF) and Negative (NF) Feedbacks we need to start these oscillators from noise and to keep them oscillating with constant amplitude in time, two tasks that we did in [1] by the counterbalance of an excess of PF by a CF in a convenient oscillator of $f_0 \rightarrow 0$.

With an output carrier of non null frequency $f_0 \neq 0$ (not the “dc carrier” used to show basic ideas on a CF in [1]) we can speak properly about noise that the CF finds in-phase with the carrier whose amplitude it keeps in time and about noise it finds in-quadrature with it. Added to this, a baseband noise of some kHz bandwidth only occupies a relative narrow band around a carrier with f_0 in the tens of MHz for example. This allows using a narrow-band approach around f_0 to speed calculations (e.g. the factor Q_0 of the $L-C-R$ of **Figure 1(a)** is defined at f_0 , but for $Q(f_0) = Q_0 = 100$, its value and meaning remains for a sideband frequency $1.001f_0$). From the above it isn't difficult to realize that a narrow-band CF *working synchronously with the carrier* at frequency $f_0 \neq 0$ will damp well the noise $2FkTR$ V²/Hz it sees in phase, whereas the noise $2FkTR$ V²/Hz it sees with phase error of -90° will mislead it so as to create the Pedestal of $2FkTR$ V²/Hz

around f_0 shown in [1]. We have to say that this Pedestal of noise that will lead to a *feedback-induced Pedestal of phase noise* was not considered in [6] because it is not the random modulation of f_0 that we called *Technical phase noise* in [1].

It is worth noting that the oscillating voltage of **Figure 1(b)** decays with $\tau_0 = 2RC$, not with $\tau_E = RC$ as one might expect from the $R-C$ circuit used in [1]. The reason is that the energy stored in this $L-C$ resonator not always gives voltage liable to Convert electrical energy into heat as it gave in the $R-C$ circuit of [1]. Due to the (electric \leftrightarrow magnetic) exchange of energy existing in this resonator of $f_0 \rightarrow 0$, *the energy it contains only is in electrical form half the time on average*, as it is shown in **Figure 2** for a lossless $L-C$ resonator. This is why the energy present in an $L-C-R$ resonator with $f_0 \neq 0$ has two times larger lifetime ($\tau_U = RC$) than that of the energy present in the resonator with $f_0 \rightarrow 0$ studied in [1] that was $\tau_U = RC/2$. Hence, the noise spectrum of DRs taking place in the resonator of **Figure 1(a)** will have half the bandwidth (e.g. $f_c/2$ around f_0 , see **Figure 3(b)**) of the bandwidth found in [1] for the baseband noise of the $L-C-R$ parallel resonator with $L \rightarrow \infty$ that was $f_c = 1/(2\pi\tau)$ Hz around $f_0 \rightarrow 0$ (see **Figure 3(a)**).

Since the noise power Dissipated by R does not depend on the L shunting C because Equipartition sets the mean square voltage noise in C [2], the two spectra of **Figure 3** must have the same $4kTR$ V²/Hz amplitude for $f_0 \gg f_c$ as it will happen in high- Q_0 resonators where $f_c \ll f_0$. This reasoning becomes less straightforward in low- Q_0 resonators where $f_c \approx f_0$ and they won't be considered for simplicity. The case with $f_0 \rightarrow 0$ of [1] can help in this case to sketch the aimed noise spectrum.

This reasoning giving directly the spectrum of thermal noise in $L-C-R$ resonators considers that the energy each DR dissipates is no other than the Fluctuation of energy $\Delta U = q^2/(2C)$ stored by its preceding TA [2] and that the rate λ_T of TA-DR pairs only depends on R since λ_T defines G by (1). It's worth noting that $f_c/2 = f_0/(2Q_0)$

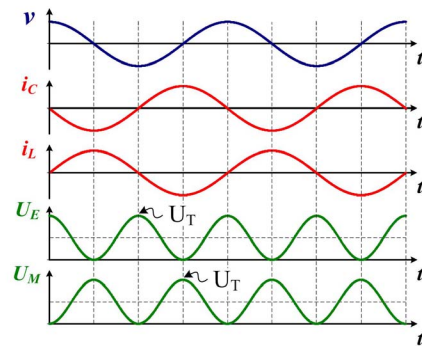

Figure 2. Voltage, currents and periodic Fluctuation at $2f_0$ of the electrical (U_E) and magnetic (U_M) energies when the resonator of **Figure 1(a) has no losses (e.g. $R \rightarrow \infty$).**

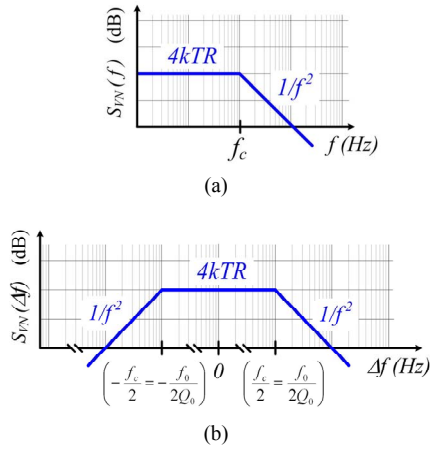

Figure 3. (a) Noise spectrum of the L - C resonator of Figure 1(a) when its $L \rightarrow \infty$; (b) Noise spectrum of the L - C resonator of Figure 1(a) when its $L > 0$ is finite.

in **Figure 3(b)** is the offset Δf from the carrier frequency f_0 where the Pedestal of Phase Noise [3,7,8] meets the Lorentzian line proposed in [4].

Mimicking what we did in [1] to sustain a dc voltage $v(t) = V_{Ref} + v_\varepsilon = V_0$ in C by a CF counterbalancing at each instant the excess of PF that had built $v(t)$ previously, let's use again those feedbacks to build a sinusoidal voltage $v(t)$ of amplitude V_0 in C from its own thermal noise and to sustain it in time once it has reached an amplitude close to a reference $V_{Ref}(t)$. Knowing that the ideal L - C resonator for which **Figure 2** applies would sustain a sinusoidal Fluctuation of electrical energy at $2f_0$ where $2\pi f_0 = (LC)^{-1/2}$, **Figure 4** shows the PF used to shunt an L - C - R resonator by a resistance $-R_{FB}$ to overcompensate its losses represented by R . This is done by feeding-back a current $i_{FB}(t) = v(t)/R_{FB}$ by the network of transconductance $\beta_Y = -1/R_{FB}$ V/A, the same type of feedback used in Figure 4 of [1]. For $R_{FB} = R$, this PF would compensate exactly the power lost at each instant in R , thus the power lost in R at any f . Although this exact compensation will fail at high f because the finite bandwidth BW_{FB} of the feedback of **Figure 4**, it will work well at typical oscillation frequencies f_0 , provided a fast enough electronics is used. Given that the effects of any phase error in the loop due to the finite BW_{FB} and its associated phase noise were shown in [6], we will consider this PF as perfectly in-phase at f_0 .

To start the oscillator from thermal noise of C , the PF of **Figure 4** has to create a Gain > Losses condition in the loop (e.g. $1/R_{FB} > 1/R$). Comparing this **Figure 4** with **Figure 4** of [1] with a similar PF, we can see that the rectifier D_1 of [1] disappears due to the irrelevance of the sign of the first step $\pm q/C$ V of noise that, amplified by the PF during t_{start} , will build the oscillating $v(t)$ whose amplitude will drive the CF of the ALC system or limiter. Mimicking [1], a NF counterbalances the excess

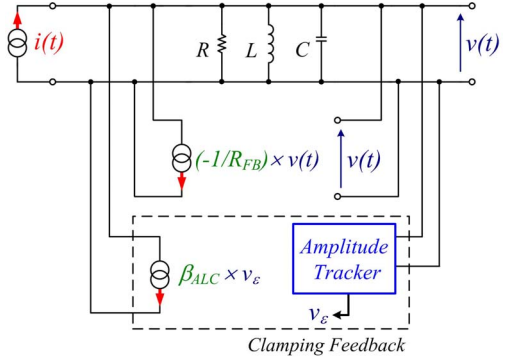

Figure 4. Feedback scheme of an oscillating loop around the L - C resonator of Figure 1(a) that uses PF to provide loop gain and NF to clamp the output amplitude (see text).

of PF once the aimed amplitude is reached. This is a CF whose implementation was discussed in [1] and that we will simplify by considering that an “amplitude tracker” gives the small error signal $v_\varepsilon = V_0 - V_{Ref}$ required to drive this CF. Without electrical noise, $v_\varepsilon(t)$ would be the difference between the sinusoidal signal $v(t)$ of amplitude V_0 and a reference signal of the same frequency and phase, but slightly lower amplitude V_{Ref} to generate this error signal. Thus, $v_\varepsilon(t)$ would be a sinusoidal signal synchronous with $v(t)$, with amplitude $v_\varepsilon \gg V_{Ref}$. The NF of $v_\varepsilon(t)$ through the transconductance β_{ALC} would counterbalance at each instant the excess of transconductance $\Delta\beta_Y$ used during t_{start} . Using the Clamping Factor of [1] given by $CL = V_{Ref}/v_\varepsilon \gg 1$ and considering that $\Delta\beta_Y$ is driven by $v(t)$, which is $(CL + 1)$ times larger than the $v_\varepsilon(t)$ signal driving the CF (see Equation (8) in [1]), the aforesaid counterbalance requires:

$$(CL + 1)\Delta\beta_Y = \beta_{ALC} \Rightarrow \beta_{ALC} = (CL + 1) \times \frac{R - R_{FB}}{(R \times R_{FB})} \quad (2)$$

Thus, the transconductance β_{ALC} that feeds back negatively the resonator with the error signal $v_\varepsilon(t)$ will be much higher than the transconductance $\beta_Y = 1/R_{FB}$ that allows the reliable start of the oscillator (e.g. by a loop gain $T_{start} = 2$ as we used in [1]).

Accepting a 0.1% amplitude error and $T_{start} = 2$ (e.g. $R_{FB} = R/2$) like those values used in [1] we have: $CL = 10^3$. Using these values in (2) we find that the NF counterbalancing the excess of PF to clamp the output amplitude at $1.001V_{Ref}$ will be shunting the resonator by a resistance $R_{DIF} = R/1001$. This will be so for any signal affecting $v_\varepsilon(t)$ as the random series of DRs that form the noise of C . Because DRs appear randomly in time, they endure 50% noise in-phase with $v_\varepsilon(t)$ or with the carrier to which the CF is phase-locked, and 50% noise in-quadrature with $v_\varepsilon(t)$ (recall **Figure 7** of [1]). Therefore, the 50% noise power born in-phase with the carrier will be highly damped by the CF (recall **Figure 8** of [1]) whereas the other 50%, (a Lorentzian or band-pass noise

spectrum of density $2kTR V^2/\text{Hz}$ around f_0 with bandwidth f_c) will be enhanced by the broadening of its spectrum away from $\pm f_c/2$ [1] as shown in **Figure 5**. This is the Pedestal of electrical noise that will exist for separations from the carrier (Δf) higher than $f_c/2 = f_0/(2Q_0)$.

As we discuss in [1] the width of this Pedestal will depend on the factor Q_0 of the resonator and on the loop gain T_{start} and Clamping Factor CL used in the design of the oscillator. Added to this, the CL of a limiter would have to be taken in an average form, because as the output amplitude approaches its limit, the clamping action becomes harder. This means that the bandwidth of the Pedestal shown in **Figure 5** is design-dependent and that is why it has not been specified.

3. Fluctuation-Induced Noise in L-C Resonators: Thermal FSK or PSK Modulations

In the model for electrical noise of [2], the voltage noise coming from the DRs taking place in the resonator is the *Effect* whose *Cause* is the series of TAs appearing randomly at the average rate $\lambda_T s^{-1}$ of (1). Since each DR comes from the *integration in time* of the impulsive current of each preceding TA, a possible Phase Modulation (PM) of the carrier by DRs will be equivalent to its Frequency Modulation (FM) by TAs. This way, the PM approach to Phase Noise of [4] and the FM one of [9] are well understood by the equivalence between FM due to a modulating signal $x_m(t)$ and PM due to the time integral of $x_m(t)$. Concerning noise, it's worth mentioning that when the $L-C-R$ resonator is in Thermal Equilibrium (TE), its noise spectrum is that of **Figure 3(b)**. No noise figure F exists in this case because there is neither feedback electronics nor heating effects that could increase resonator's temperature ($T^* > T$) as we discuss in [1]. When the PF and CF of the loop balance mutually to sustain the output amplitude V_0 , the noise increases by F and also split into the damped noise and Pedestal of **Figure 5**, which shows *noise with reference to TE* (a native spectrum of density $4kTR V^2/\text{Hz}$ increased by the noise of the electronics and by any small heating effect $T^* > T$, both included in F) *together with two noises that only exist out of TE* when the resonator stores the energy

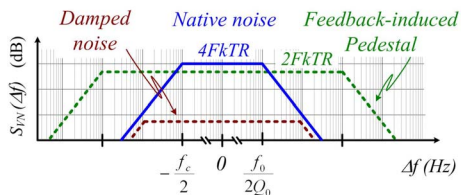

Figure 5. Noise spectra of the $L-C$ resonator of **Figure 4** (dotted lines) together with the noise it had in Thermal Equilibrium (solid line) without feedbacks (see text).

U_E corresponding to the amplitude V_0 of $v(t)$.

Since $v(t)$ is quite a sinusoid let's have some figures by using $v(t) = V_0 \times \sin(2\pi f_0 t)$. Therefore, the energy stored in the resonator is: $U_E = CV_0^2/2$ J and the average power converted into heat by R (e.g. the mean power leaving the resonator as heat) is: $P_0 = V_0^2/(2R)$. This leakage of energy per unit time is the price we pay to store U_E in this resonator out of TE. Another price we pay concerns the purity of the voltage $v(t)$ on C because the aimed *exchange of energy at $2f_0$* shown in **Figure 2** will be disturbed by the thermal interaction between the resonator and its environment. This exchange of energy represented by R is carried out by a *charge noise* [2] disturbing the otherwise periodic exchange of charge between L and C that would give the sinusoid of V_0 volts peak (or CV_0 Coulombs peak) we aim to have in C . Considering the distinction made in [1] between power *Converted* into heat and power *Dissipated* by DRs we can leave aside the power $P_0 = V_0^2/(2R)$ assuming that the small heating of the resonator it will produce ($T^* > T$) will be included in F . Having considered the *effects due to Dissipations of energy in the electrical noise* of the loop, we have to consider now the *effects due to each Fluctuation of electrical energy* preceding each Dissipation because both processes endure a charge noise associated with Displacement Currents (DiC) in C that disturb its otherwise periodic Fluctuation of charge coming from the energy exchange between magnetic and electric susceptances in an $L-C$ resonator. The factor 2 we had to use in [1] to obtain the charge noise power of a series of current pulses mimicking fat TAs, reflected these two charge noises. To say it bluntly, each fast DiC of weight q in C due to a TA is followed by an opposed and slower DiC of equal weight q and opposed sense linked with its DR. This is why phase noise is a nice scenario to test the validity of the Quantum-compliant model of [2], which was able to explain $1/f$ excess noise [10] and flicker noise [11] as consequences of thermal noise.

Considering that the damping of a DR during a period of $v(t)$ is small, **Figure 6** shows the Phase and Amplitude changes that a TA produces in the otherwise sinusoidal signal $v(t)$ when it occurs at instant $t = \alpha$ within one period T_0 . It's worth realizing that a null damping of this DR triggered by a TA would mean that this resonator has no losses, but having suffered a TA it must be lossy [2]. This contradiction, however, is solved by considering that the damping of a DR in a resonator with only one TA per period (e.g. $\lambda_T/f_0 \approx 1$) would be vanishingly small: Using (1) at room T , a $Q_0 \approx 0.3 C/q$ would appear. Thus, **Figure 6** is undistinguishable from the true one for typical $L-C-R$ resonators with $Q_0 > 50$ for example. Since each TA is a charge noise of one electron in C , it always gives the same voltage shift $\pm q/C$ V no matter the instant α it takes place. However, the *Amplitude Modulation*

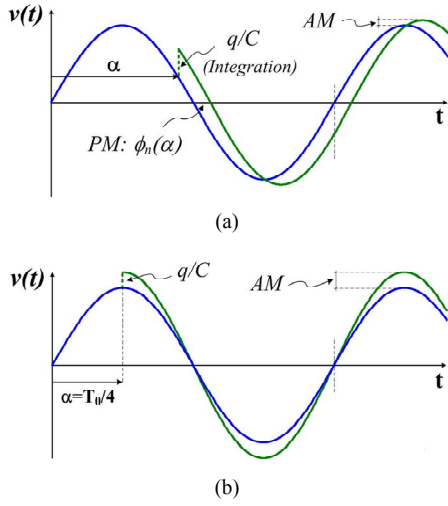

Figure 6. Effects of a Thermal Action in the capacitance of the L-C oscillator of Figure 4 when the damping of this Fluctuation of energy is small during one period (see text).

(AM) it produces depends on α [7,8], reaching its maximum for $\alpha = T_0/4$ or $\alpha = 3T_0/4$, when the charge in C has its peak value $Q_p = CV_0$. From typical circuit values we can say that this non null AM is negligible however, because in an L-C tank with $C = 16$ pF and $V_0 = 10$ V, the peak charge appearing in one of the plates of C is: $Q_p = 1.6 \times 10^{-10}$ C, thus $N \approx 10^9$ electrons. The change of ± 1 electron in N at $\alpha = T_0/4$ by a TA would be an AM of 0.001 parts per million (-180 dB) that would be lower for AM due to TAs taking place at other instants. Thus, we won't consider this AM in this introductory paper on phase noise, although it can play a role in high-frequency, low-power oscillators.

The spectrum of the output signal will contain both the Damped and the Feedback-induced Pedestal of noise shown in **Figure 5**, although the former will be buried by the Pedestal. Added to them there will be a high line at f_0 due to the "carrier" whose amplitude is kept by the CF or better said: a broadened line around f_0 , because **Figure 6** shows an undeniable *Phase Modulation* (PM) for each TA, except for two among millions that could take place exactly at $\alpha = T_0/4$ or $\alpha = 3T_0/4$. Since each TA displaces one electron in C , it shifts its voltage by $\Delta v = \pm q/C$ V depending on its sign and the oscillation continues with new amplitude A and phase ($\omega_0 t + \phi\Delta$). Thus we have:

$$A \sin(\omega_0 t + \Delta\phi) = V_0 \sin(\omega_0 t) \pm \frac{q}{C} \quad (3)$$

Since each TA is an impulsive current unable to change the magnetic energy stored in the resonator (this requires some elapsed time), it only will modify the instantaneous energy of C to pass its charge $Q(t)$ to $Q(t) \pm q$. The associated energy change is therefore:

$$\begin{aligned} \Delta U_{TA} &= \frac{(Q(t) \pm q)^2}{2C} - \frac{(Q(t))^2}{2C} \\ &= \frac{q^2}{2C} \pm \frac{2qQ(t)}{2C} = \frac{q^2}{2C} \pm qV_0 \sin(\omega_0 t) \end{aligned} \quad (4)$$

thus equal to the Fluctuation $\Delta U = q^2/(2C)$ J needed to displace one electron between plates of C (or to break charge neutrality separating $+q$ and $-q$ charges in C) plus the energy required to move a charge q in a region where charge neutrality already was broken by opposed charges like the dipolar charge of C that is the source of its voltage $V_0 \sin(\omega_0 t)$ between terminals.

The very different scale for ΔU and qV_0 in actual circuits appears by considering their ratio $qV_0/\Delta U = 2N$, for N being the peak number of electrons in one of the plates of C . For $C = 16$ pF and $V_0 = 5$ V we have: $qV_0/\Delta U = 10^9$, thus meaning that the addition of one electron to the negative plate of this circuit needs a 10^9 times higher energy than the Fluctuation of energy ΔU required to displace one electron between the plates of C with $V_0 = 0$. This huge value raises this question: *Where comes from this huge energy when a TA makes an electron to appear as a charge $-q$ on the negative plate of C ? A likely source is $U_f = C_f V_0^2/2$ [1], a big energy the free electron had in the Conduction Band (CB) just before being captured or collected by the negative plate. The ratio $U_f/qV_0 = V_0/(2V_T) \approx 100$ at room T suggests that to appear as a charge $-q$ at the negative plate of C with $V_0 = 5$ V, the electron borrows a small fraction (1%) of the energy U_f it had as a free carrier in the CB, thus releasing only $0.99U_f$ J as heat in the negative plate that collects it. For a TA of opposed sign in which the electron appeared as a charge $-q$ at the positive plate of C with $V_0 = 5$ V, an energy $1.01U_f$ J would be released as heat on the positive plate on its arrival (e.g. the energy U_f it had as a free carrier in the CB plus the energy acquired from the electric field in C by an electron passing from its negative plate to its positive one).*

Due to the equal probability for positive and negative TAs, the average energy Converted into heat by each TA is U_f and this account well for Joule effect accordingly to [1]. Continuing our reasoning from (4), the new amplitude A of the oscillation after a TA will come from this energy balance:

$$\frac{1}{2}CA^2 = \frac{1}{2}CV_0^2 + \frac{q^2}{2C} \pm qV_0 \sin(\omega_0 t) \quad (5)$$

From (4) and (5), the phase shift $\Delta\phi$ produced by a TA occurring at time t within the period is [12]:

$$\Delta\phi = \arcsin \left(\frac{V_0 \sin(\omega_0 t) \pm \frac{q}{C}}{A = \sqrt{V_0^2 + \frac{q^2}{C^2} \pm \frac{2q}{C}V_0 \sin(\omega_0 t)}} \right) - (\omega_0 t) \quad (6)$$

Using N , the peak number of electrons accumulated in the negative plate of C without TAs, (6) becomes:

$$\Delta\phi = \arcsin\left(\frac{N \sin(\omega_0 t) \pm 1}{A = \sqrt{N^2 + 1 \pm 2N \sin(\omega_0 t)}}\right) - (\omega_0 t) \quad (7)$$

Because TAs have the same probability to increase N than to decrease it, the average phase shift resulting from (7) for the λ_T TAs per second given by (1) is null, but this is not so for *the mean square phase shift* due to the huge amount of TAs taking place within a period $T_0 = 1/f_0$ of the output signal. Although it's easy to show that for N values like those found in actual oscillators (e.g. $N > 10^6$) an increment or decrement of one electron gives a similar $\Delta\phi$ shift with opposed sign, we prefer to use the equal number of positive and negative TAs on average to add the square of (7) for a positive TA (e.g. with its \pm signs replaced by + signs) to the square of (7) with its \pm signs replaced by - ones, thus obtaining *twice the mean square phase shift* of a TA taking place at time t in C . Representing half this sum in the first quarter of period ($0 \leq \omega_0 t \leq \pi/2$) we obtain the *s-curve* shown in **Figure 7** by a solid line that represents the *square phase shift due to a TA occurring at time $t = \alpha$* within the first quarter of period of the output signal.

For $N > 20$, this averaging of positive and negative TAs is numerically irrelevant and one can take directly the *s-curve* of **Figure 7** from *the square* of (7) for any sign of TAs. The dashed line of **Figure 7** is the linear approximation to the *s-curve* that shows quickly that its mean value in this quarter of period is half its maximum value for $\omega_0 t = 0$, thus $1/2N^2$. Since this *s-curve* and $\Delta\phi(\omega_0 t) = [1 + \cos(2\omega_0 t)] / (2N^2)$ fit very well, we can integrate directly $\Delta\phi(\omega_0 t)$ to obtain the same mean value. Therefore, the *mean square phase modulation* (PM) of each TA is:

$$\langle (\Delta\phi)^2 \rangle = \frac{1}{2} \times \left(\frac{q}{C \times V_0} \right)^2 = \frac{q^2}{2 \times V_0^2 \times C^2} = \frac{1}{2N^2} \quad (8)$$

Although (8) is the mean square PM expected for TAs

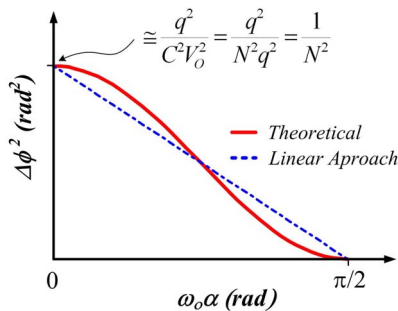

Figure 7. Square phase-shift due to a Thermal Action as a function of the instant α where it takes place (solid line) and its linear fitting giving its mean square phase shift $1/(2N^2)$.

occurring in the first quarter of the period, the mean square PM expected for TAs occurring in other quarters is the same because the *s-curve* for $\pi/2 \leq \omega_0 t \leq \pi$ is the mirror image of **Figure 7** around $\pi/2$, thus an *s-curve* increasing from zero to $1/N^2$. Since (1) is the rate of TAs giving the *charge noise power* $4kT/R C^2/s$ of the capacitance C [2] (usually taken as the noise density $4kT/R A^2/Hz$ of the resistance R) the extra noise added by the feedback electronics, collected by the effective Noise Figure F used in [3], leads to multiply (1) by F to collect all the TAs disturbing the resonator per unit time. Thus, the mean square Phase Modulation accumulated during one period T_0 by $F\lambda_T$ TAs per second disturbing the otherwise sinusoidal carrier of amplitude V_0 , will be:

$$F \times \lambda_T \times T_0 \times \langle (\Delta\phi)^2 \rangle = F \times \frac{2\pi}{Q_0} \times \frac{kT/2}{U_E} \quad (9)$$

when a period finishes, a new one starts and the phase modulation accumulated in the finished period is lost. Thus the way the phase of $v(t)$ is degraded by TAs *as time passes within each period* will be:

$$\langle \phi_n^2(t) \rangle = F \lambda_T \langle (\Delta\phi)^2 \rangle t = F \times \frac{kT}{C} \times \frac{1}{V_0^2 \times RC} \times t \quad (10)$$

This linear dependence with time comes from the quasi-linear, quasi-continuous accumulation of TAs as time passes due to its huge rate $F\lambda_T$. Considering now the Phase Noise model of [4], where the Phase in an ensemble of many identical oscillators subjected to white noise diffuses in time, we can consider that this diffusion is a Wiener process whose mean square is given by Equation (3) of [4], which is:

$$\langle \phi_n^2(t) \rangle = 2 \times D \times t \quad (11)$$

Thus, this nice model for an ensemble of M identical L - C oscillators subjected to white noise is formally equal to our single L - C -based oscillator subjected to the white charge noise of [2]. Identifying terms in (10) and (11) we have:

$$D^* = F \times \frac{kT}{C} \times \frac{1}{V_0^2 \times 2RC} \quad (12)$$

$$= \frac{F}{2} \times \frac{kT}{C} \times \frac{1}{V_0^2} \times \frac{\omega_0}{Q_0} = \frac{F}{2} \times D$$

that gives the phase diffusion constant D found in Equation (21) of [4], but multiplied by $F/2$. This discrepancy concerning F comes from the fact that oscillators used in the theoretical ensemble of [4] have perfect electronics ($F = 1$), but the discrepancy concerning the factor $1/2$ is more subtle because it is the factor $1/2$ that appears for *the average efficiency of TAs to modulate the Phase of the carrier depending on the instant α* where they take place (see **Figure 7**). Therefore, let's replace the *phase*

diffusion constant D handled in [4] by our *phase degradation constant* D^* given by (12) that is $F/2$ times higher (although its physical meaning is similar) in order to use Equation (3) of [4] for the Lorentzian line that gives the spectral content of the output signal $v(t)$ of our oscillator. Doing it and for D^* given in rad/s, we obtain:

$$S_V(\Delta\omega) = V_0^2 \times \frac{D^*}{(\Delta\omega)^2 + (D^*)^2} = \frac{V_0^2}{D^*} \times \frac{1}{1 + \left(\frac{\Delta\omega}{D^*}\right)^2} \quad (13)$$

where $\Delta\omega$ is 2π times the frequency offset $\Delta f = f - f_0$ from the central frequency f_0 taken as carrier frequency (see below (3) of [4] for example), although the spectrum of $v(t)$ is not monochromatic, but a Lorentzian line having a -3 dB bandwidth $BW_C = D^*/\pi$ Hz around f_0 as (13) shows. Moreover, given the *integration in time* done by C of each impulsive displacement current or TA to give a voltage step $\Delta v = q/C$ *modulating in phase* the “carrier” of static frequency f_0 , what we have described is the *Frequency Modulation* (FM) of this carrier at f_0 by the impulsive current noise of the TAs. To say it bluntly: the displacement currents generating electrical noise [2] modulate in frequency the aimed carrier of static frequency f_0 and this shows vividly that $v(t)$ is not a pure sinusoidal carrier giving a spectral line at f_0 , but a FM carrier whose frequency $f(t)$ wanders randomly with time around f_0 , tracking the random wandering around zero of the noise current of spectral density $4FkT/R$ A²/Hz that reflects the thermal noise of C . This noise includes the Nyquist noise traditionally assigned to R , the noise coming from the feedback electronics and the extra noise coming from the unavoidable heating of the resonator. Converting into heat a power $P_0 = V_0^2/(2R)$ W on average when it stores the energy U_E fluctuating at $2f_0$.

Equation (13) gives the spectral dispersion $S_V(\Delta\omega)$ of the mean-square carrier voltage $V_0^2/2$ of $v(t)$ due to the effect of TAs (*Fluctuations*) creating electrical noise in C [2]. Therefore, $S_V(\Delta\omega)$ is a spectral density with the same units V²/Hz of the noise density $S_{NV}(\Delta\omega)$ coming from energy *Dissipations* shown in **Figure 5**. Integrating (13) from $\Delta\omega \rightarrow -\infty$ to $\Delta\omega \rightarrow +\infty$ we obtain: $V_0^2/2$, thus indicating that the mean Signal power $P_0 = V_0^2/(2R)$ converted into heat by R that we have calculated considering $v(t)$ as perfectly sinusoidal, is scattered in a line of non null width around f_0 . It is worth noting that (13) nothing says about the small, but not null AM of $v(t)$ already discussed concerning **Figure 6**. A possible reason is that an AM lower than one electron in $N \approx 10^8 - 10^9$ is a residual AM lying below -180 dB from V_0 itself taken as 0 dB reference, although perhaps the reason is a deeper one because this residual AM disappears when the quantization of charge for each TA is neglected, as it would do a noise model unaware about the discrete nature of the electrical charge. In any case,

the power density $S_V(\Delta\omega)$ near f_0 is so high, that the noise sidebands due to this residual AM will be overridden by it in the same way the feedback-induced Pedestal overrides the damped noise in **Figure 5**.

The random noise added by the TA-DR pairs to the sinusoidal $v(t)$ of **Figure 6** also can be handled by a small, randomly-oriented, noise vector A_N , added to a big phasor of amplitude V_0 rotating uniformly in time at f_0 times per second to represent a “carrier” of static frequency f_0 . This noise vector can be decomposed into a small noise vector A_{AM} along the phasor that represents a random AM of the carrier, and a small noise vector A_{PM} orthogonal to the phasor that represents random PM of the carrier. Due to the random orientation of A_N , there is equal probability for A_{AM} and A_{PM} at each instant, thus meaning that the native noise density $4FkT/R$ V²/Hz of **Figure 5** (e.g. that of the resonator without feedback), would contain a 50% Amplitude noise and 50% Phase noise added to the carrier. Whereas the ALC system or amplitude limiter would reduce (by design) the 50% AM noise quite effectively, the remaining 50% Phase noise would mislead this system in such a way that its $2FkT/R$ V²/Hz density would be extended up to frequencies well above $f_0/(2Q_0)$, being this the Pedestal of electrical noise shown in **Figure 5**. We could say that the Pedestal of noise of **Figure 5** only is *Phase noise of the resonator amplified by the ALC system* or limiter designed to reduce amplitude noise because electrical noise contains both Amplitude as well as Phase noise when the ALC system is phased locked to a frequency $f_0 \neq 0$.

The Pedestal of $2FkT/R$ V²/Hz shown in **Figure 5** leads to the Pedestal of Phase noise shown in **Figure 8**, where it appears together with $S_V(\Delta\omega)$ given by (13), *both normalized by the mean-square carrier voltage* $V_0^2/2$ in order to have the familiar single-sideband spectral density of Phase Noise $L\{\Delta\omega\}$ found in Equation (12) of [7] for example. Using (12) in (13) to find the frequency offset Δf_{F-D} where $S_V(\Delta\omega)$ drops down to $2FkT/R$ V²/Hz or where the phase noise due to Fluctuations of energy in C and the phase noise due to Dissipations of energy in R modified by the feedback are equal, we obtain:

$\Delta f_{F-D} = f_0/(2Q_0)$ as shown in **Figure 8**. This result harmonizes the Line Broadening proposed in [4] with Leeson’s formula concerning the transition from a region where phase noise varies as $1/(\Delta\omega)^2$ to a Pedestal of Phase Noise far from f_0 [3]. Added to the above, Leeson also gave a region where Phase Noise passed to vary as $1/(\Delta\omega)^3$ as we approach more f_0 [3], a region that does not appear in **Figure 8**. This is so because we haven’t considered yet “coloured noises” like those coming from the resistance noise known as excess noise in Solid-State devices [10] or from the flux noise known as flicker noise in vacuum devices [11] that we are going to consider next.

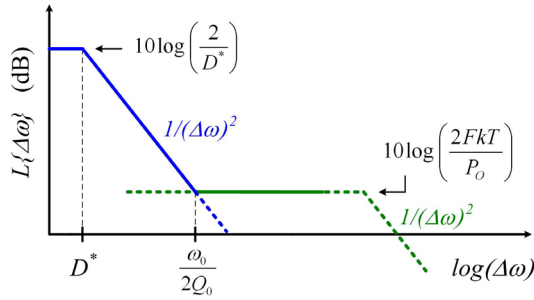

Figure 8. Lorentzian line of phase noise (“carrier” line) due to Thermal Actions in C, together with the phase noise pedestal generated by the clamping feedback (see text).

Recalling what we wrote about (13): that its Lorentzian Line reflects a FM of the carrier of frequency f_0 by a noise of flat spectrum that is F times the Nyquist noise current usually assigned to R , we can explain easily the region of Phase Noise varying as $1/(\Delta\omega)^3$ that appears in oscillators, especially in those using resonators of high Q_0 (thus $D^* \rightarrow 0$) and with electronics bearing $1/f$ -like noise below some frequency f_{CN} , no matter if it is excess noise (resistance noise in Solid-State devices [10]) or flicker noise (flux noise in vacuum ones [11]). As we wrote under (13), the output power of the oscillator appears within a -3 dB bandwidth $BW_C = D^*/\pi$ Hz around f_0 . From (12), the constant D^* for resonators with high Q_0 values is correspondingly low. This is why the phase noise found in these oscillators uses to be the region of (13) where it is proportional to $1/(\Delta\omega)^2$, a “skirt” of Phase Noise that drops down to the Pedestal as $\Delta\omega$ increases for $\Delta\omega \gg D^*$. Let’s consider the Phase Noise of these oscillators that use high Q_0 resonators when the flat spectrum of noise that modulates in Frequency the carrier is filtered previously by a *low-pass filter* with cut-off frequency $f_{col} = \omega_{col}/(2\pi) < f_0/(2Q_0)$.

Figure 9(a) shows the spectrum of this filtered noise modulating the carrier of static frequency f_0 and **Figure 9(b)** shows the Phase Noise spectrum it produces. The Phase Noise roll-off changes from $1/(\Delta\omega)^2$ for $\Delta\omega < \omega_{col}$ to $1/(\Delta\omega)^4$ for $\Delta\omega > \omega_{col}$, an effect due to the integration of the modulating signal that precedes the Phase Modulation in a Frequency Modulator. This integration in t leads to a term inversely proportional to the modulating frequency f_m , whose effect in the phase noise spectrum appears at $\Delta\omega = \omega_m$. Hence, the flat spectrum of the modulating signal gives phase noise proportional to $1/(\Delta\omega)^2$ whereas the region whose power density drops as $1/(\omega_m)^2$ gives phase noise proportional to $1/(\Delta\omega)^4$. From this fact, it is easy to understand that a sum of the above low-pass filtered signals will give a sum of Phase Noise spectra like that of **Figure 9(b)**, because the FM modulator we are handling is *linear and time-invariant*. With our new noise model [2] we don’t need to abandon time-invariance as it is done in [7,8].

Thus, a sum of low-pass filtered noise spectra like those of **Figure 10(a)** that synthesize a region of $1/f$ noise, will give the Phase Noise spectrum of **Figure 10(b)** with a region of Phase Noise proportional to $1/(\Delta f)^3$, as the empirical one reported by Leeson [3].

Considering that the $1/f$ noise of Solid-State devices is synthesized in the way shown in **Figure 10(a)** [10] and that the flicker noise of vacuum tubes with $1/f^\xi$ with $\xi \approx 1$ also comes from a similar synthesis process [11],

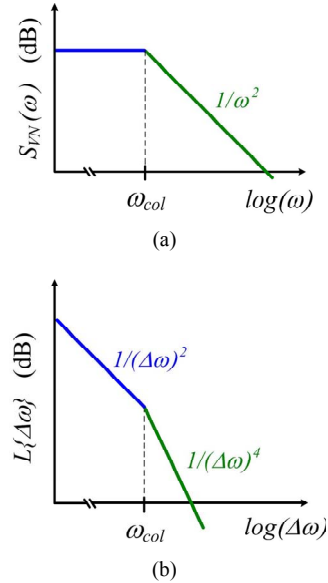

Figure 9. (a) Low-pass filtered white noise modulating in frequency (FM) a carrier of static frequency f_0 ; (b) Energy spectrum of the FM carrier thus obtained represented as Phase Noise around f_0 (see text).

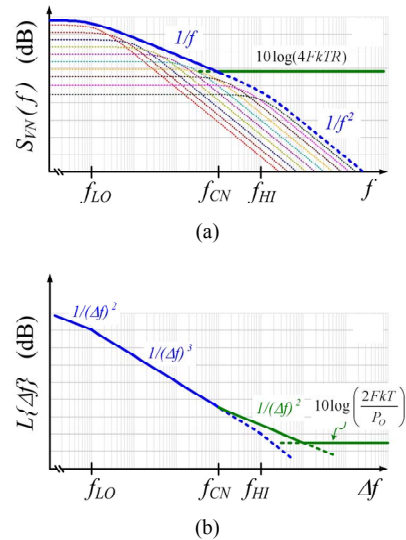

Figure 10. (a) White noise together with $1/f$ excess noise that modulate in frequency (FM) a carrier of static frequency f_0 ; (b) Energy spectrum of the modulated carrier represented as Phase Noise around f_0 (see text).

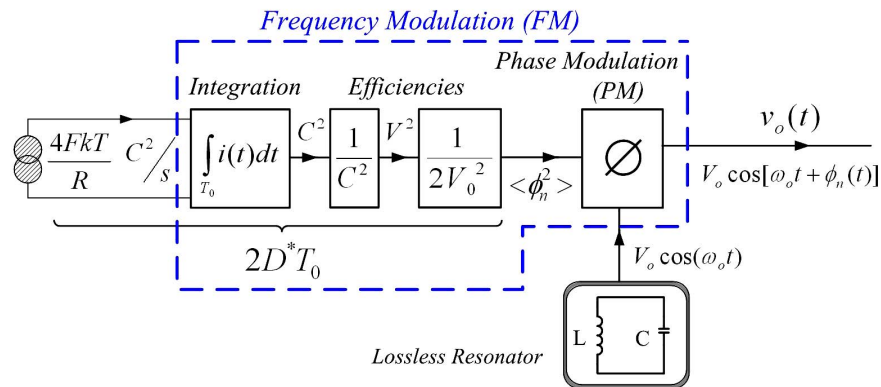

Figure 11. Embedded FM modulator existing in oscillators based on L-C resonators due to the Thermal Actions that the new model for electrical noise identifies with the charge noise power $4FkT/R$ C^2/s existing in C at temperature T due to its losses represented by R and to its noise figure F .

we have shown the origin of Phase Noise varying as $1/(\Delta f)^3$. As a way to show the mechanism giving the Line Broadening of the output spectrum of oscillators based in L-C resonators, **Figure 11** summarizes the Charge Controlled Oscillator (CCO) we have when we use an L-C resonator and feedback electronics aiming to sustain a periodic Charge Fluctuation at f_0 in this resonator at temperature T . This CCO models the Line Broadening around f_0 of these oscillators that will be a Lorentzian line for white current noise and that will have another shape if the current noise modulating the carrier is “coloured” noise. This Phase Noise around f_0 is the random Phase Modulation of the carrier by DRs (or its random FM by TAs) that one obtains neglecting the decay of each DR within one period of $v(t)$, thus being valid for resonators with negligible Dissipation (e.g. $Q_0 > 50$). Since each DR really decays as it dissipates the electrical energy stored in C by its preceding Fluctuation or TA, these random decays also generate electrical noise of bandwidth $\pm f_c/2$ around f_0 whose power in-quadrature with the output signal mislead the CF designed to reduce amplitude noise, thus producing the Pedestal of phase noise $2FkT/P_0$ that accompanies their carrier Line Broadening and that the FM modulator of **Figure 11** does not take into account.

4. Conclusions

Using a new model for electrical noise based on Fluctuation-Dissipation of electrical energy in an Admittance, the Phase Noise of resonator-based oscillators is explained as a simple consequence of thermal noise. The discrete Fluctuations of energy involving single electrons produce the observed Line Broadening whereas the noise associated to subsequent Dissipations modified by the feedback electronics, lead to the Phase Noise Pedestal far from the “carrier”. Therefore, a monochromatic carrier of static frequency f_0 never is obtained and the oscillator’s

output corresponds to a Frequency Modulated carrier of central frequency f_0 whose instantaneous frequency $f(t)$ wanders randomly with time around f_0 , tracking the random wandering of the noise current of density $4FkT/R$ A^2/Hz that collects the noise of the resonator, its electronics and the extra noise due to any heating effect due to the Signal power converted into heat in the resonator. In summary: Phase Noise shows the way the oscillator senses the charge noise power $4FkT/R$ C^2/s that exists in its L-C resonator while it stores the energy corresponding to the output signal it sustains in time because these oscillators always are CCOs driven by the charge noise of their capacitance.

REFERENCES

- [1] J. I. Izpura and J. Malo, “Thermodynamical Phase Noise in Oscillators Based on L-C Resonators (Foundations),” *Circuits and Systems*, 2011, Article in Press.
- [2] J. I. Izpura and J. Malo, “A Fluctuation-Dissipation Model for Electrical Noise,” *Circuits and Systems*, Vol. 2, No. 3, 2011, pp. 112-120. doi:10.4236/cs.2011.23017
- [3] D. B. Leeson, “A Simple Model of Feedback Oscillator Noise Spectrum,” *Proceedings of IEEE*, Vol. 54, 1966, pp. 329-330. doi:10.1109/PROC.1966.4682
- [4] D. Ham and A. Hajimiri, “Virtual Damping and Einstein Relation in Oscillators,” *IEEE Journal of Solid-State Circuits*, Vol. 38, No. 3, 2003, pp. 407-418. doi:10.1109/JSSC.2002.808283
- [5] H. B. Callen and T. A. Welton, “Irreversibility and Generalized Noise,” *Physical Review*, Vol. 83, No. 1, 1951, pp. 34-40. doi:10.1103/PhysRev.83.34
- [6] J. Malo and J. I. Izpura, “Feedback-Induced Phase Noise in Microcantilever-Based Oscillators,” *Sensors and Actuators A*, Vol. 155, No. 1, 2009, pp. 188-194. doi:10.1016/j.sna.2009.08.001
- [7] T. H. Lee and A. Hajimiri, “Oscillator Phase Noise: A Tutorial,” *IEEE Journal of Solid-State Circuits*, Vol. 35, No. 3, 2000, pp. 326-336. doi:10.1109/4.826814

- [8] A. Hajimiri and T. H. Lee, "A General Theory of Phase Noise in Electrical Oscillators," *IEEE Journal of Solid-State Circuits*, Vol. 33, No. 2, 1998, pp. 179-194. [doi:10.1109/4.658619](https://doi.org/10.1109/4.658619)
- [9] E. Hegazi, J. Rael and A. Abidi, "The Design Guide to High Purity Oscillators," Kluwer Academic, New York, 2005.
- [10] J. I. Izpura, "1/f Electrical Noise in Planar Resistors: The Joint Effect of a Backgating Noise and an Instrumental Disturbance," *IEEE Transactions on Instrumentation and Measurement*, Vol. 57, No. 3, 2008, pp. 509-517.
- [11] J. I. Izpura, "On the Electrical Origin of Flicker Noise in Vacuum Devices," *IEEE Transactions on Instrumentation and Measurement*, Vol. 58, No. 10, 2009, pp. 3592-3601. [doi:10.1109/TIM.2009.2018692](https://doi.org/10.1109/TIM.2009.2018692)
- [12] J. Malo, "Contribución al diseño de lazos de realimentación Electrónica para sistemas electromecánicos (MEMS) resonantes: ruido de fase generado en lazos osciladores por sus realimentaciones," PhD. Thesis, Chapter III (in Spanish) Universidad Politécnica de Madrid, Madrid, Article in Press, 2012, pp. 70-145.