

Random Laser of R6G Dye and TiO₂ Nanoparticles Doped in PMMA Polymer

Baha T. Chiad¹, Kamil H. Latif², Firas J. Kadhim¹, Mohammad. A. Hammed¹

¹*Department of Physics, College of Science, University of Baghdad, Baghdad, Iraq*

²*Ministry of Environment, Baghdad, Iraq*

E-mail: mohammed.hameed75@scbaghdad.edu.iq; mohammed.hameed75@yahoo.co

Received July 29, 2011; revised August 3, 2011; accepted September 5, 2011

Abstract

The random laser (RL) based on organic Rhodamine 6G (R6G) laser- dye and Titanium dioxide (TiO₂) suspended nanoparticles have been prepared with polymethylmethacrylate (PMMA) as a host. Both liquid and spray-coated homogeneous film samples of 22.4 μm - 30.1 μm thickness range were use. Optimum concentrations have been determined depending on the normal fluorescence spectra which give evidence that the laser dye provides amplification and TiO₂ nanoparticles as scatter center. At the optimum concentrations, results of the random laser (RL) under second harmonic Nd: YAG laser excitation show that the values of bandwidth at full width half-maximum (FWHM) and the threshold energy are about 9 nm and 15 mJ respectively, which represent the minimum value for the liquid samples in the current research. Correspondingly, these values become 14 nm and 15 mJ for film sample. The broadening that can be attributed to the concentration quenching of a laser dye at high concentration levels has been observed.

Keywords: Random Laser, Random Gain Media, Laser Resonator

1. Introduction

Random lasers (RL) are unique sources of stimulated emission in which the feedback is provided by scattering in a gain medium [1,2]. Random laser effects have been observed in a variety of organic and inorganic gain media including powders of solid-state luminescent and laser crystals [3,4], liquid laser dyes with scatterers [5], polymeric films with and without intentionally introduced scatterers [6], ZnO scattering films and nanoclusters [7], dye-infiltrated opals [8], porous media infiltrated with liquid crystals with dyes [9] and many others. Random lasers are very attractive for a variety of applications, low coherent random laser sources can be advantageous in holography, laser inertial confinement fusion (driver sources for megajoule lasers), transport of energy in fibers for medical applications, and other applications, detailed reviews of random lasers can be found in [10,11]. Random lasers are strongly scattering media that amplify light. There are striking similarities between these systems and more conventional lasers based on a gain medium enclosed in a cavity with two mirrors to provide optical feedback. An example is the observation of a threshold for lasing action and frequency narrowing

in random lasers. Evidently, the optical properties of random lasers are quite different from those of conventional lasers: the propagation of pump and fluorescence light is diffusive in a random laser. In contrast with cavity systems, scattering is actually advantageous. Since feedback is provided by multiple scattering, the random laser threshold is lowered by a stronger scattering, *i.e.*, a shorter transport mean free path, because the feedback is more efficient. It has been shown that the threshold in random lasers is reduced dramatically when the photon transport mean free path approaches the stimulated emission wavelength [12].

On other hand, gain narrowing denotes a decrease of the width of the spectrum of the emitted light triggered by an increase in the pump fluence. The width will be characterized by the at full width half maximum (FWHM). Gain narrowing is observed in all laser systems [13]. In a random laser the FWHM of the spectrum of the emitted light below the threshold of the laser is approximately the width of the emission spectrum of the gain medium (typical 40 nm) for R6G. However, far above threshold, this FWHM can be as narrow as 10 nm. A measure for the gain narrowing is the narrowing factor NF, defined as the FWHM of the emitted light below

threshold (FWHM below) divided by the FWHM of the emission spectrum of a random laser far above threshold (FWHM above) [14,15].

In this work, RL based on mixtures of suspended TiO₂ nanoparticles of different concentrations and were mixed with R6G and the polymer PMMA was used as a host [16], and both the TiO₂ and R6G concentrations were diluted in its corresponding solvent down to 10⁻⁶ mol/l. From fluorescence measurements of the above concentrations, it was noticed that a TiO₂ concentration of 10⁻³ mol/l had the highest intensity and the narrowest bandwidth for both liquid and film samples. At this optimum TiO₂ nanoparticles concentration, the emission intensity spectra at different Nd:YAG pumping energies were investigated to determine the lasing threshold [17].

2. Experimental

2.1. Chemicals and Preparation

Rhodamine 6G laser dye (C₂₈H₃₁N₂O₃Cl) with molecular weight 479.02 g/mol supplied by Lambda Physics LC (5900): Ethanol alcohol (C₂H₅OH) with spectroscopic grade purity supplied by Gainland Chemical Company and chloroform (CH₃CCl₃) with spectroscopic grade purity supplied by Philip Harris chemical company UK. Poly-Methyl methyleacrylate (PMMA) with chemical forms (CH₂CH₃COOCH₃), supplied by fulka (Switzerland), and used as a host for laser dye and nanoparticles. Titanium dioxide (TiO₂, nanoparticles 50 nm) of Anatase crystal structure was acquired from Dupont Inc. The mean particle size of TiO₂ suspension is 48.7 nm, which is prepared as film, determined by electron microscope.

The solutions of laser dye prepared by dissolving the required amount of the dye in ethanol. The concentrations of dye solutions were: 10⁻³, 10⁻⁴, 10⁻⁵ and 10⁻⁶ mol/l. The powder of TiO₂ was suspended in chloroform and its concentration was estimated based on the known weight fraction of TiO₂ in the suspension. The mixing volume ratio of R6G 10⁻⁵, 10⁻⁶ mol/l: TiO₂ 10⁻³, 10⁻⁴, 10⁻⁵, 10⁻⁶ mol/l: PMMA 10⁻² mol/l is 3:4:3 ml for the samples in liquid phase. Spray pyrolysis technique used to prepare the film samples. **Figures 1 (a)-(b)** shows the photographs of some prepared samples.

Figure 2 illustrates a scanning electron microscope (SEM) topography image for the film sample. The thickness of coating in three different regions of the film as approximately the same giving indication of the homogeneity of the prepared film.

2.2. Experimental Setup

Figure 3 illustrates the experimental setup of RL measurement. The liquid samples were placed in cuvettes length of 1 cm, and width of 0.5 cm. The pumping source

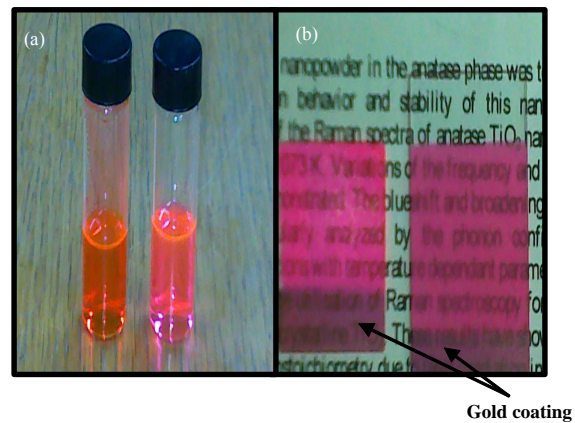

Figure 1. Photos image of some prepared samples; (a) liquid phase, (b) films.

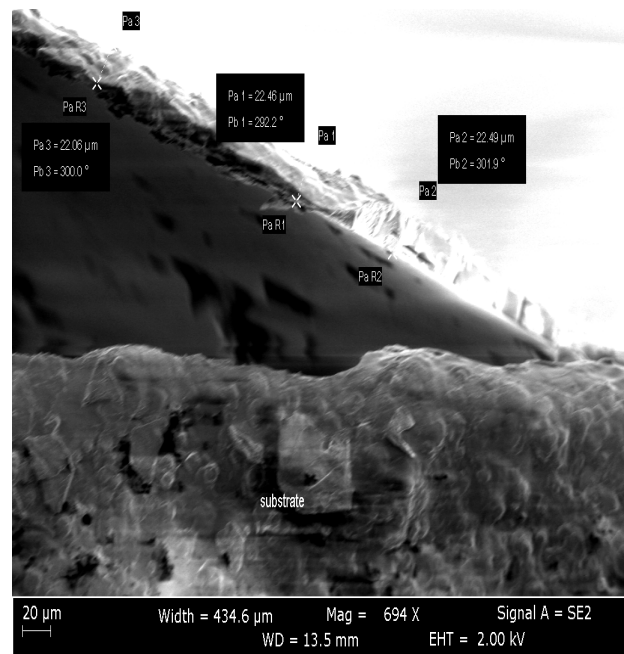

Figure 2. Image of SEM for measuring thickness sample as film.

of RL is random polarized *Q*-switched Nd: YAG 2nd harmonic generation ($\lambda_{pump} = 532$ nm, with a pulse width of ~6 ns, repetition rate of 6 Hz, and focal spot size of ~4 mm). A monochromator and photomultiplier tube was used, successively, to select and detect the emission signals. The liquid sample was stirred at about 5 minutes before recording the spectrum in order to prevent TiO₂ nanoparticles from excessive precipitation. On the other hand, cylindrical lens was used to extend the laser spot along the film sample and thus, enabling a precise measurement of the emission signals by monochromator and photomultiplier tube. The emission spectra were recorded at different gradually-increasing pumping energies.

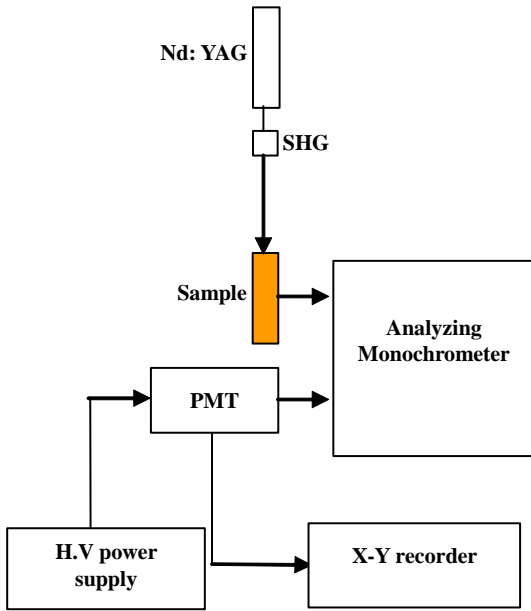

Figure 3. Schematic diagram of RL experimental setup.

3. Result and Dissection

The fluorescence spectra of the liquid samples at 10^{-5} mol/l R6G and different concentrations of TiO_2 are illustrated in **Figure 4**. It is obvious that the maximum wavelength is occurred at 562 nm with not significant shift. The R6G dye solution of 10^{-5} mol/l concentration with the mentioned concentrations of TiO_2 suspension gives the optimum results. In this case, high intensity and hence narrow bandwidth at FWHM (18 nm) were observed comparing with 40 nm in the case of without TiO_2 in accordance to the inset of **Figure 4**. Likewise, minimum value of 20 nm bandwidth at FWHM for 10^{-6} mol/l of R6G and of TiO_2 10^{-3} mol/l of was registered. The latter value is less than that of 45 nm in the case of without TiO_2 . These results are agreement with the published data in reference [18].

Figure 5 shows the fluorescence spectra of film samples that prepared at 10^{-3} mol/l R6G and the same mentioned concentration of TiO_2 . It can be seen that 25 nm is the minimum bandwidth at FWHM, for λ_{max} of 568 nm, for the film sample derived at concentration 10^{-3} mol/l of both R6G and TiO_2 , according to the inset of **Figure 5**.

The bandwidth values at FWHM were calculated by applying the following equation (1):

$$\Delta\lambda \text{ effected} = \int I_{\lambda} d\lambda / I_p \tag{1}$$

where $\Delta\lambda$ effected bandwidth values I_p peak intensity I_{λ} wavelength intensity.

We can also find the values of bandwidth at full width

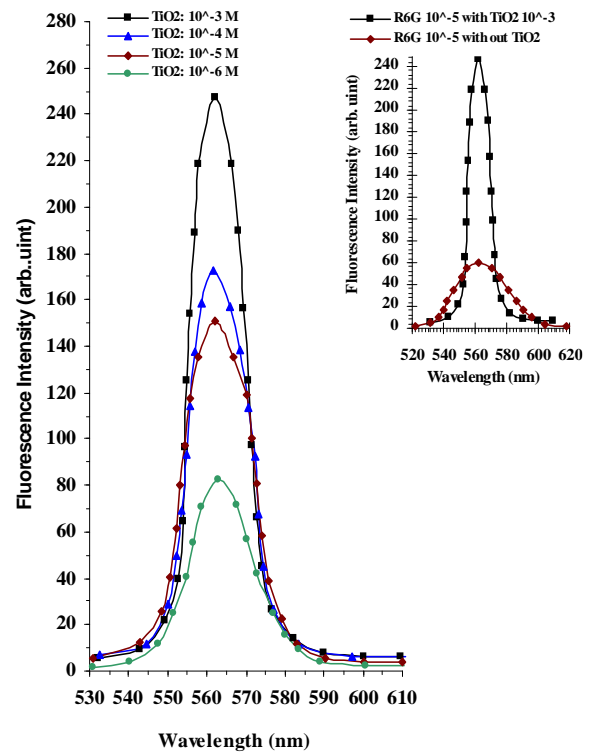

Figure 4. The fluorescence spectra of liquid sample with 10^{-5} mol/l R6G and 10^{-3} , 10^{-4} , 10^{-5} , 10^{-6} mol/l hosted by polymer PMMA.

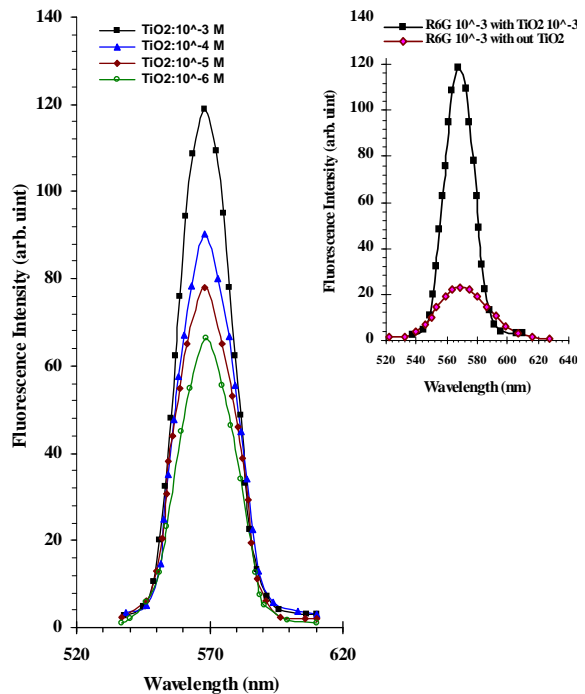

Figure 5. The fluorescence spectra of film samples with 10^{-3} mol/l R6G and 10^{-3} , 10^{-4} , 10^{-5} , 10^{-6} mol/l hosted by polymer PMMA.

half-maximum (FWHM) using Excel program that calculates the area under the approach and distribute them to the highest value of intensity.

These results suggest preliminary that concentrations of both R6G and TiO₂ (in liquid and film samples) are the optimum for both amplification and multiscattering processes in this type of random laser. The minimum bandwidth gives an indication that these processes are performed in parallel without noticeable effect on the dye response, Thus, achieving one of the important conditions of RL system.

Figure 6 shows the emission spectra, obtained from RL setup, at different pumping energies for 10⁻⁵ mol/l R6G: TiO₂ 10⁻³ mol/l in the case of liquid sample. The transition centered at wavelength approximately of 562 nm, as can be seen from normal fluorescence in **Figure 4**, and RL threshold is approximately 15 mJ as can be determined from **Figure 7**.

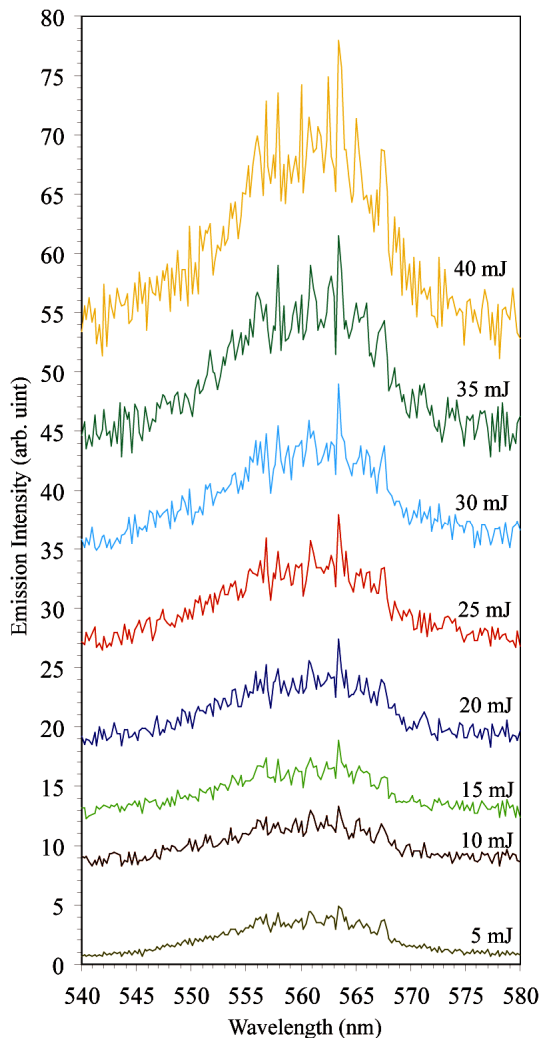

Figure 6. Emission spectra of liquid sample: 10⁻⁵ mol/l R6G:10⁻³ mol/l at different pumping energies.

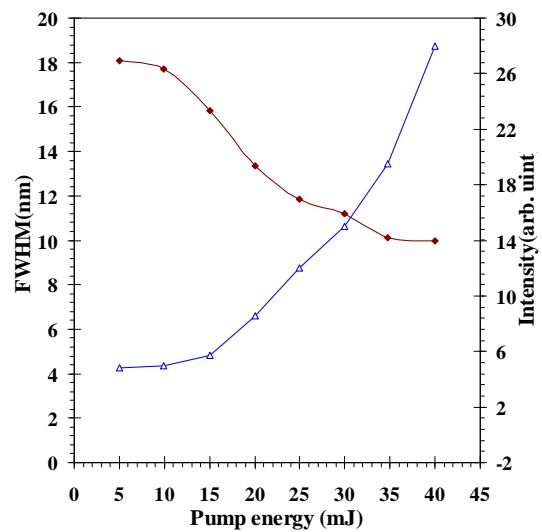

Figure 7. Random laser threshold determined from the relation of maximum intensity and FWHM at different of pumping energies for a liquid sample : 10⁻⁵ mol/l R6G: TiO₂ 10⁻³ mol/l.

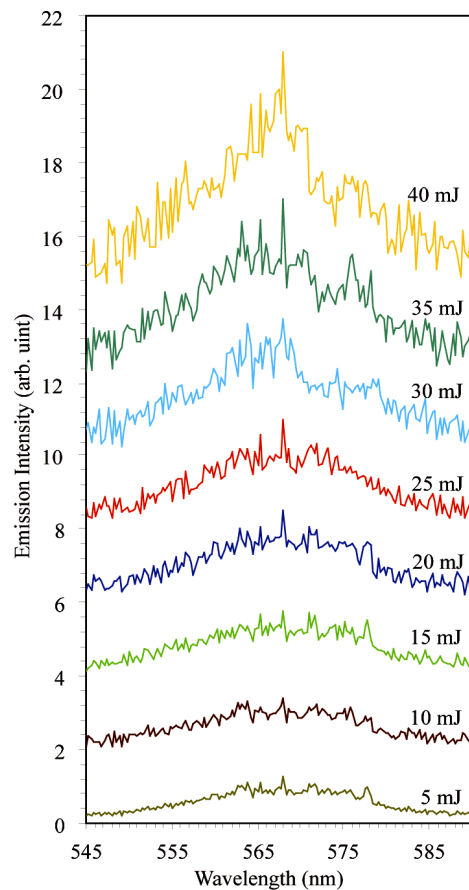

Figure 8. Emission spectra of film sample: 10⁻³ mol/l R6G:10⁻³ mol/l at different pumping energies.

At small pumping intensity, only spontaneous emission can be observed which is characterized by the maximum spectral bandwidth value at $\lambda = 562$ nm and at (FWHM) of about 15 nm. With increasing the pumping energy up to 40 mJ, a much narrower peak with the same maximum wavelength is found to be about ~ 9 nm at FWHM. The same behavior is observed for the liquid sample of 10^{-6} mol/l R6G: 10^{-3} mol/l TiO_2 . In this case, RL threshold is the same value as in the previous concentrations, but the spectrum bandwidth is at $\lambda_{\text{max}} = 558$ nm and at (FWHM) is about ~ 18 nm. Up to 40 mJ pumping energy, a much narrower peak with the same maximum wavelength is found to be about ~ 10 nm at FWHM.

The most important difference between the liquid samples, as shown in **Figures 6-8** respectively, is that for the film sample the bandwidth at FWHM is about 22 nm at 15 mJ pumping energy with $\lambda_{\text{max}} 568$ nm and at 40 mJ pumping energy the bandwidth at FWHM becomes 14 nm.

It has been noticed that the present emission spectra of film samples show broadening compared with liquid samples. This may be attributed to the concentration quenching at 10^{-3} mol/l R6G which reduces emission intensity bandwidth broadening at about 6 nm.

4. Conclusions

Two types of RL were synthesized via chemical method and spray coating technique. The statistical spectroscopic studies of the concentrations of both R6G dye and TiO_2 scatter centers were achieved giving an indication about the optimum required concentrations. The results of RL measurements show that the minimum bandwidth at FWHM is about ~ 9 nm at 40 mJ for the liquid sample at 10^{-5} R6G mol/l and $\text{TiO}_2 10^{-3}$ mol/l. Comparatively, a 14 nm bandwidth at also 40 mJ was observed for homogeneously prepared spray-coated film sample at 10^{-3} R6G mol/l and $\text{TiO}_2 10^{-3}$ mol/l, these results are not far away from the ones reported elsewhere [4,6,12,17,18].

5. Acknowledgements

We would like to appreciate the valuable technical assistance of Dr. Hani J. Kbashe, Dr. Qahtan G. AL-Zaidi and Dr. Raied K. Jamil at the optics research center of the physics department. Also, the financial support of the collage of science, Baghdad University is acknowledged.

6. References

- [1] V. S. Letokhov, "Stimulated Emission of an Ensemble of Scattering Particles with Negative Absorption," *Journal of Experimental and Theoretical Physics Letters*, Vol. 5, 1967, pp. 212-215.
- [2] V. M. Markushev, V. F. Zolin and Ch. M. Briskina, "Luminescence and Stimulated Emission of Neodymium in Sodium Lanthanum Molybdate Powders," *Soviet Journal of Quantum Electronics*, Vol. 16, 1986, pp. 281-283.
- [3] D. Anglos, A. Stassinopoulos, R. N. Das, G. Acharakis, M. Psyllaki, R. Jakubiak, R. A. Vaia, E. P. Giannelis and S. H. Anastasiadis, "Random Laser Action in Organic-Inorganic Nanocomposites," *Journal of the Optical Society of America B*, Vol. 21, 2004, 208-213.
- [4] A. M. Brito-Silva, G. André, S. L. Anderson, J. J. Alcenisio and B. A. Cid, "Random Laser Action in Dye Solutions Containing Stöber Silica Nanoparticles," *Applied Physics*, Vol. 108, 2010, p. 033508.
- [5] G. Zacharakis, N. A. Papadogiannis and T. G. Papazoglou, "Random Lasing Following Two-Photon Excitation of Highly Scattering Gain Media," *Applied Physics Letters*, Vol. 81, 2002, pp. 2511-2513.
- [6] R. C. Polson, A. Chipoline and Z. V. Vardeny, "Random Lasing in π -Conjugated Films and Infiltrated Opals," *Advanced Materials*, Vol. 13, 2001, pp. 760-764.
- [7] H. Cao, Y. Ling, J. Y. Xu, C. Q. Cao and P. Kumar "Photon Statistics of Random Lasers with Resonant Feedback," *Physical Review Letters*, Vol. 86, 2001, pp. 4524-4527.
- [8] M. N. Shkunov, M. C. DeLong, M. E. Raikh, Z. V. Vardeny, A. A. Zakhidov and R. H. Baughman, "Photonic versus Random Lasing in Opal Single Crystals," *Synthetic Metals*, Vol. 116, 2001, pp. 485-491.
- [9] D. Wiersma and S. Cavalier "Light Emission: A Temperature-Tunable random laser," *Nature*, Vol. 414, 2001, pp. 708-709.
- [10] M. A. Noginov, "Solid-State Random Lasers," (Springer Series in Optical Sciences), Norfolk State University, Norfolk, 2005.
- [11] D. S. Wiersma, "The Physics and Applications of Random Lasers," *Nature Physics*, Vol. 4, 2008, pp. 359-367.
- [12] Y. Ling, H. Cao, A. L. Burin, M. A. Ratner, X. Liu and R. P. H. Chang, "Investigation of Random Lasers with Resonant Feedback," *Physical Review A*, Vol. 64, No. 6, 2001, p. 063808. [doi:10.1103/PhysRevA.64.063808](https://doi.org/10.1103/PhysRevA.64.063808)
- [13] N. M. Lawandy, R. M. Salachandran, A. S. L. Gomes and E. Sauvain, "Laser Action in Strongly Scattering Media," *Nature*, Vol. 368, 1994, pp. 436-438. [doi:10.1038/368436a0](https://doi.org/10.1038/368436a0)
- [14] G. Beckering, S. J. Zilker, and D. Haarer, "Spectral Measurements of the Emission from Highly Scattering Gain Media," *Optics Letters*, Vol. 2, No. 2, 1997, pp. 1427-1433.
- [15] H. Cao, "Lasing in Random Media, Waves in Random Media," Vol. 13, 2003, p. 33.
- [16] C. M. Aegerter, M. Störzer, S. Fiebig, W. Bührer and G. Maret, "Observation of Anderson Localization of Light in Three Dimensions," *Journal of the Optical Society of*

America A, Vol. 24, 2007, pp. A23-A27.

- [17] X. H. Sun, X. M. Tao, P. Xue, K. C. Kwan and J. G. Dang, "Low-Threshold Random Laser with One Mirror and Feedbacks in PMMA Nano-Composite Films," *Chinese Physics Letters*, Vol. 22, No. 10, 2005, p. 222568.
- [18] V. Bulovic, "Organic Materials in Optoelectronic Applications: Physical Processes and Active Devices," Massachusetts Institute of Technology, Cambridge. **Private Communication.** 