



# Charging Station of Electric Vehicle Based on IoT: A Review

Mahmood H. Qahtan, Emad A. Mohammed, Ahmed J. Ali

Technical Engineering College, Northern Technical University, Mosul, Iraq

Email: mahmood.hameed@ntu.edu.iq, e.a.mohammed@ntu.edu.iq, Ahmed.j.ali@ntu.edu.iq

**How to cite this paper:** Qahtan, M.H., Mohammed, E.A. and Ali, A.J. (2022) Charging Station of Electric Vehicle Based on IoT: A Review. *Open Access Library Journal*, 9: e8791.

<https://doi.org/10.4236/oalib.1108791>

**Received:** April 26, 2022

**Accepted:** May 29, 2022

**Published:** June 1, 2022

Copyright © 2022 by author(s) and Open Access Library Inc.

This work is licensed under the Creative Commons Attribution International License (CC BY 4.0).

<http://creativecommons.org/licenses/by/4.0/>



Open Access

## Abstract

At present, humans face the problem of lack of fuel and environmental pollution to reduce pollution as well as fuel consumption. We have to use electric vehicles, but the spread of these vehicles is still low due to the lack of charging stations as well as their high prices. This paper reviews important research about charging stations with IoT and the charging type used in these stations, and it makes a comparison between them, as well as the sources for these stations, which may be renewable and non-renewable energy. Using IoT saves the time spent by the user looking for the stations' location with the possibility of knowing the location of charging stations by using a mobile application, as well as the possibility of placing charging stations in public places and parking stations, thus making it easier to move to the use of these new vehicles.

## Subject Areas

Wireless Communication, Computer Engineering

## Keywords

State Of Charge (SOC), Electric Vehicle, Internet of Things (IoT), Charging Station, Battery Management System (BMS), Renewable Energy Resources

## 1. Introduction

Nowadays, electric vehicles are a hot issue, and they're an important element of the intelligent world. The mobility of electric vehicles is sometimes limited. As a result, it requires regular recharging. The population is growing at an exponential rate, resulting in increased traffic congestion. As it's known that there is a finite supply of fuel on our planet, it is time to move to a different mode of transportation, and electricity is the greatest alternative for this, with electric vehicles being an example. Plug-in charging is the most often used charging method for

electric vehicles, consisting of a plug that must be attached to the car to start charging. There is no need to turn the plug on and off while using wireless charging. As a result, that makes a less-human intervention, and the electric shock danger from links that are connected will be reduced. The range of plug-in electric cars is limited, and they require huge and weighty batteries. The main advantages of wireless charging technology are that it improves the range of the automobile and reduces the battery size. It also reduces the cost of charging and the time it takes to charge the car. This leads to an increase in the environmental and financial benefits of electric vehicles, as well as their rapid acceptance [1]. Electric cars, like current gasoline vehicles, need a charging station. There are two types of charging methods for Wireless Power Transfer (WPT)-based EV batteries): static and dynamic charging. Static-charging EVs are referred to as battery electric vehicles (BEV), whereas dynamically charged EVs are referred to as on-line-electric vehicles (OLEV). The BEV can be charged at home or work. However, the EV battery's large size is its main disadvantage. The storage system must be large enough to hold a significant amount of charge, which necessitates a larger battery and a heavier EV. In an OLEV, the main site of the connected coils used for electromagnetic charging of an EV battery is placed on the road, while the secondary side is placed on the car's bottom, allowing one or more vehicles to be charged at the same time while on the road. When compared with BEVs, OLEVs have a smaller battery, which improves the vehicle's efficiency [2].

Because of the time taken by charging, it is more economical to make a car charged while it is parked. As a result, it is cost-effective to combine the charging and parking systems that use IoT technology and are user-friendly. Information may be uploaded to the cloud and smartphones at the same time. The (IoT) is the greatest platform for monitoring the state of the Wireless Power Transfer) WPT (system, since it allows for higher connection, customized sensing, processing of information and adaptability [3]. Electric vehicles (EVs) are rapidly growing due to five major global themes: 1) Depletion of fossil fuels and associated rises in fuel prices; 2) Public awareness of climate change and desire to combat it; 3) advancements in renewable energy technology and commercial effectiveness; 4) improvement of electric motors and electronic control systems that directly control EV thrust; and 5) advancements in EV supportive technologies such as Grid-to-Vehicle (G2V) and Vehicle-to-Grid (V2G) [4]. The driving range of electric vehicles is determined by the battery capacity, but the power-train's complexity is also essential. The goal of recent research has been to extend the range of electric cars [5]. As a result, battery management and monitoring solutions are required. A thorough analysis of Li-ion batteries EVs are used is described in [6]. Many varieties of Li batteries' fundamental operating ideas, assembly, and performance are explained and proposed for high-capacity batteries that require a rapid charging mechanism. (SOC) is one of the most important critical enablers for determining the capacity state of the battery so that it may be charged and discharged safely, extending its life. The ratio be-

tween the battery's balancing relationship and its rated capacity can be expressed in this way. As a result, SOC aids with battery management [7]. In [8], the State Of Charge (SOC), which refers to the available capacity of battery, is one of the most essential metrics of a battery. Several factors influence SOC, including battery chemistry, age, temperature, load characteristics, and so on [9]. The SoC is the percentage of a battery's remaining charge capacity in its maximum possible battery capacity. The SoC of the battery serves the same purpose as the gasoline fuel gauge used in a gasoline-powered car, indicating how far energy is left in the battery to supply an EV. The correct computation of battery SoC not only helps offer real-time info about the battery's outstanding capacity and energy, nevertheless, it furthermore assures a dependable and safe vehicle process. However, determining the SoC of batteries is challenging because they are composite electrochemical devices with nonlinear performance that fluctuates based on internal and external inputs. To satisfy the demands of electric cars, however, tens too many cells must be linked in parallel and series due to the low voltage and energy of a single cell. Four different types of batteries used in Electric vehicles: Lithium-Ion (Li-Ion), Molten Salt (Na-NiCl<sub>2</sub>), Nickel Metal Hydride (Ni-MH), and Lithium Sulphur (Li-S), all of which have the same electric energy storage capacity. Due to its high energy density and enhanced power per mass battery unit, Li-Ion batteries are now the most widely utilized technology in electric cars, allowing the creation of various types of batteries with decreased weight and dimensions at competitive rates. The disadvantage of Li-Ion batteries is their high generated operational temperature, which can have an impact on an energetic performance, as well as their lifetime and safety during use [10].

The SOC of a battery may be determined in a variety of methods. These methods may be classified into three groups: The three categories are electrochemical, adaptive, and electrical. Electrochemical techniques are exceedingly exact, but they require electrical power. As a result of the battery's chemical composition, software implementation is difficult. A comparable circuit model and a solution approach are required for adaptive battery processes [11]. The accuracy of adaptive techniques is determined by the efficiency of the corresponding model. Observable factors like charge/discharge current, terminal voltage, and internal resistance, on the other hand, are all required for electrical techniques. Due to its simplicity and ease of implementation, the coulomb counting (electric) approach is one of the most often used approaches to estimate SOC [12]. The battery state of charge is an important BMS evaluation indicator (SOC). The SOC refers to the amount of charge left in the battery cells about its capacity. There is currently no direct technique to determine the SOC of a Li-ion battery. As a result, it can only guess at the SOC by looking at battery metrics like current, voltage, temperature, and so on [13]. SOC is defined mathematically as Equation (1).

$$\text{SOC} = \frac{Q_{\text{available}}}{Q_{\text{rated}}} \quad (1)$$

where ( $Q_{\text{available}}$ ) is available in the continuing battery charge, and ( $Q_{\text{rated}}$ ) is the

rated battery capacity,  $Q_{\text{rated}}$  is not constant during the lifetime of the battery,  $Q_{\text{rated}}$  varies during the battery's lifetime depending on different external issues such as ambient temperature, discharge current, battery aging, SOH, the number of charges/discharge. In [14], it had been proved that an internal resistance equivalent circuit model (ECM) with a comparable charging and discharging curve could be used. To anticipate the state of charge indicated in **Figure 1**, the Kalman filter (KF) and (ECM) are utilized. When the Coulomb counting Ampere-hour integral approach was employed to estimate SOC, the voltage of the cell to the battery pack readings matched to SOC.

A Battery Management Systems (BMS's) calculation of battery SoC is always an important component. The precise and trusted calculation of the SoC can serve as a critical criterion for the design of a vehicle's energy management and control system. As a result, a wider variety of approaches for predicting battery SoC in real-time have been presented to make it easier to compare various techniques, they've been divided into four groups as explained briefly below. The categorization is shown in **Figure 2**.

### 1) Looking-Up Table-Based Techniques

The open-circuit voltage (OCV), impedance, and other outside (static) characteristic features of the batteries are directly mapped to their SoC. By calculating their parameters and formerly using a table named the (looking up table) technique, this table was established using the relations between SoC and one or more factors, we may suppose the SoC. Consider the OCV of the battery as an example. **Figure 3** shows the OCV vs. SoC of battery for a lithium-ion polymer battery (LiPB). It shows that as a LiPB the OCV of cells is increasing in lockstep with the cell's SoC. If the OCV knew, that may deduce the SoC of the battery by observing the table between SoC and OCV. For most battery management solutions, this relationship is used to estimate SoC. It may be effectively utilized to calibrate an incorrect SoC. However, measuring the accurate OCV in real-time is difficult since measuring battery OCV necessitates removing the power and allowing the battery to rest for a long period. However, because battery impedance measurement is reliant on the measuring instrument, it cannot be utilized to operate electric vehicles. This version of the SoC valuation technique is suited for usage in a lab environment.

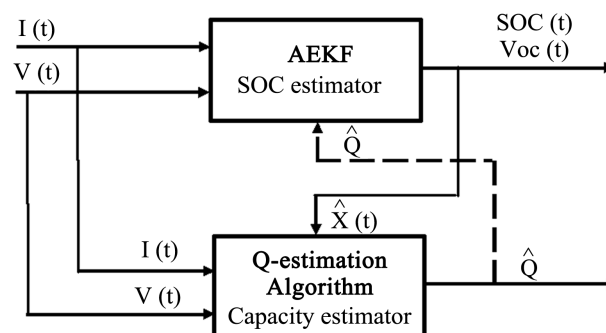

**Figure 1.** Adaptive extended Kalman filter.

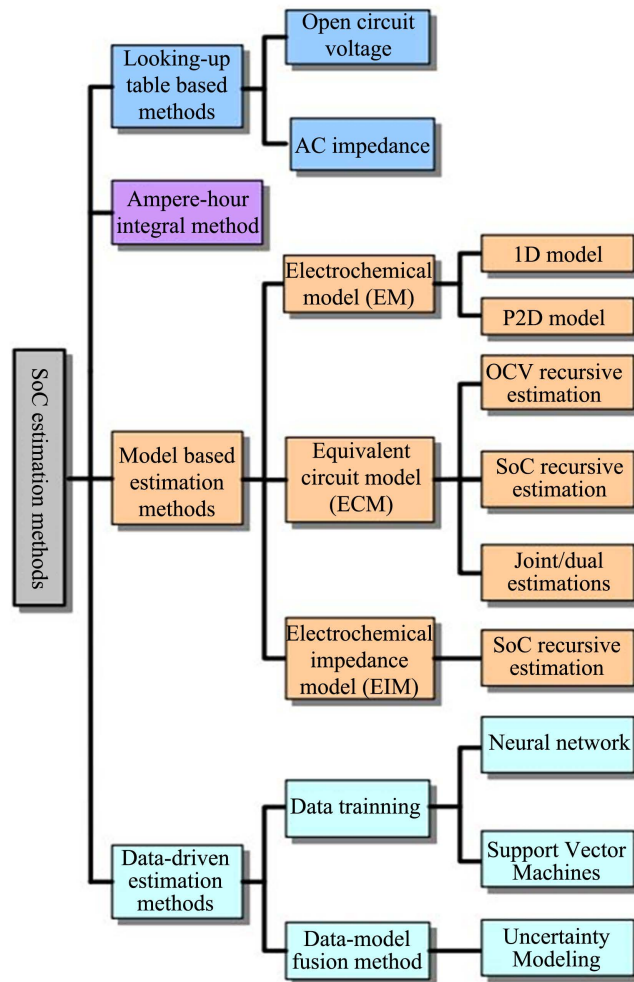

Figure 2. Categories of the SOC estimation methods.

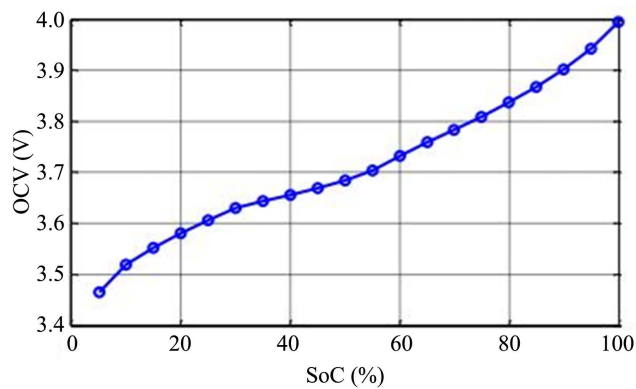

Figure 3. OCV with SOC curve of a LiPB battery cell.

## 2) An Ampere-Hour Integral Technique

The ampere-hour integral approach may be used to calculate the variance of the SoC when the maximum usable capacity of a battery is known and its current can be monitored precisely. We can get the accurate SoC if we know the initial SoC. Because there are no severe negative effects during regular operation,

this approach is particularly accurate for batteries. However, there are three limitations to this approach of estimating the SoC that must be addressed first. To begin, the initial SoC must be determined. Second, battery current measurement inaccuracies due to random disturbances like noise and temperature drift are unavoidable. Finally, due to changes in operating circumstances and battery aging levels, the Q (Q specifies the greatest available capacity) must be recalibrated. The combination of the aforementioned issues would reduce the method's reliability even further. As a result, the ampere-hour integral approach is more suited to collaborating with other techniques, such as model-based methods. Because battery capacity varies depending on operating conditions and age, it should not be used in SoC estimates. As a consequence, we make full use of our resources.

### **3) The Model-Based Estimation Techniques**

A wide variety of batteries types for vehicle power management and BMS have been proposed as battery technology has progressed. Electrochemical model (EM), equivalent circuit model (ECM), and electrochemical impedance model (EIM) are three types of models that are often utilized. In model-based SoC estimate methodologies, battery representations are written as state calculations. To estimate or deduce the interior state of batteries, a variety of nonlinear state estimation techniques and adaptive filters are utilized. Common algorithms include the Kalman filter, Luenberger observes, PI (proportion integration) observer, H-infinity ( $H_{\infty}$ ) observer, and sliding mode observer. A popular nonlinear estimating and machine learning tool is the Kalman filter.

### **4) The Data-Driven Estimation Methods**

Data-driven control approaches simply create a controller based on the system's input-output data. The calculations and assumptions established in the plant modeling stage are eliminated since these approaches do not need a precise plant model.

### **Engineering Applications: Recommendation**

A sort of online data-driven estimating technique is the data-model combination approach. It combines an online data-driven technique with a model-based strategy, with the data-driven method discovering system parameters in real-time using online measurements the paradigm with real-time behaviour can considerably increase the controlled system's performance. The internet measuring data and offline data have a relative yet interdependent relationship. To construct the controller, the live data-driven approach simply uses real-time measurements of the regulated system and information collected from data processing. It has the ability to bring people together, constancy, and resilience of the controlled system. Some of the most often used sets of rules for internet data-driven approaches include the Recursive least squares (RLS) based approach, the support vector machine (SVM), and bias-correction (BC) based techniques.

In [15], the internet of things (IoT) is a collection of physical items, intelligent gadgets, cars, buildings, and sensors, as well as communication protocols and software, that gather, exchange, store, analyze, and process data. The Internet of

Things is built on the sensor-based tight connection between the digital and physical worlds [16]. In [17], the core model of IoT is a 3-layer architecture consisting of the Application, Network, and Perception Layers, which was chosen from a pool of proposed models. However, various additional models have been offered in recent literature that adds further abstraction to the IoT architecture. **Figure 4** depicts various popular structures.

Understanding the IoT building components will help you obtain a better understanding of the IoT’s true meaning and operation. The six essential elements are needed to offer IoT capabilities as shown in **Figure 5**.

1) Identification. It’s critical for the IoT to give services a name and match them to demand IoT identification systems including electronic product codes (EPC) and ubiquitous codes (uCode). In addition, differentiating between object ID and address is critical when dealing with IoT devices. The object’s ID is its name, such as T1 for a specific temperature sensor, and the object’s address is its communication network address.

2) Sensing is the process of gathering data from connected network things and sending it to a data warehouse, database, or the cloud. The data gathered is analyzed to determine the best course of action based on the services sought.

3) Communication IoT communication technologies allow heterogeneous items to communicate with one another to provide specialized smart services. IoT nodes should typically operate at low power in lossy and noisy communication

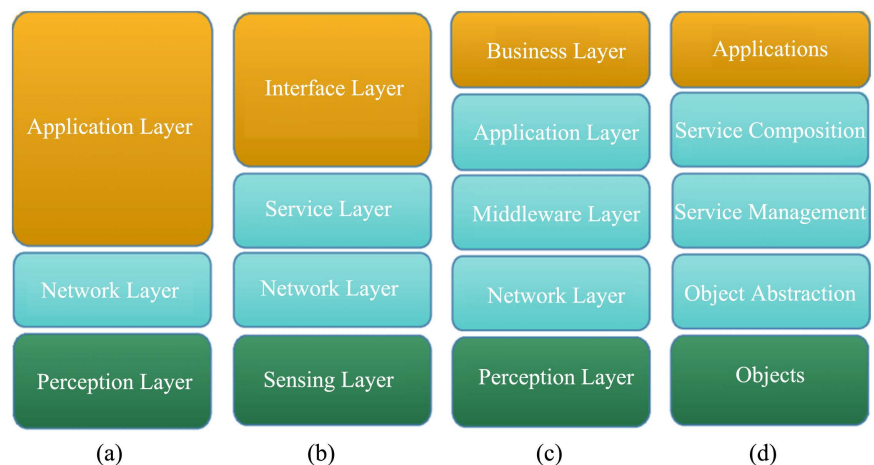

**Figure 4.** IOT architecture: (a) 3-layer, (b) 4-layer, (c) 5-layer, and (d) SOA-based [18] [19].



**Figure 5.** IoT elements.



networks. IoT communication protocols include WiFi, Bluetooth, IEEE 802.15.4, Z-wave, and LTE-Advanced.

4) Computing abilities are represented by processing units (e.g., microcontrollers, microprocessors, SOCs, FPGAs) and software applications, and computation is the IoT's mind. Some of the hardware platforms meant to run IoT applications include Arduino, UDOO, Friendly ARM, Intel Galileo, Raspberry PI, Gadgeteer, BeagleBone, Cubieboard, Z1, WiSense, Mulle, and T-Mote Sky.

5) Services The four categories of IoT services include identity-related services information combination services, collaborative-aware services, and ubiquitous services. Identity-related services are the most basic and vital services that are used in other types of services. Every software attempting to bring real-world objects into the virtual world must first recognize them.

6) In the IoT, the ability of various technologies to extract knowledge intelligently in order to provide critical services is referred to as semantic. Knowledge extraction includes finding and exploiting resources, as well as modelling data. It also requires locating and analysing data in order to determine the best course of action for giving the finest service.

## 2. Literature Review

Customers accept electric vehicles because they are simple to use. It has several requirements, one of which being suitable charging and parking space. By including these two systems, a proposed model is meant to provide an efficient solution. The design of a system that can manage free parking slots and pricing schedules is important to consider during the process of preparing preliminary designs and feasibility studies. Such types of parking systems were incapable of accepting all sorts of vehicles. There is a demand for charging stations as well as parking for electric vehicles. The suggested strategy allows users to reserve charging space using their smartphones. The system then coordinates all actions associated with it based on information such as the vehicle's arrival time, the state of the battery, etc. Customer manager, vehicle manager, map manager, and lot manager are the primary components. Java Platform and Enterprise Edition is the software utilized (Java EE). Another thing to consider is the security idea. This necessitates the usage of a user ID, which is also used in the billing process [20].

In [21] produced a mobile android application with the capability of providing a list of charging station (CS) positions in a geographical manner closest to the EV's position, but the EV user may not know whether the nearby Charging Station(CS) is available or not, resulting in the selection of the incorrect CS. Also in [22], the vehicle's precise position is provided by this tracking technology. In addition, the online application notifies commuters of the estimated time of arrival (ETA) and the distance that the vehicle must go. The suggested tracking system comprises of three modules: 1) Global Positioning System (GPS); 2) Raspberry Pi; 3) Web Application. The vehicle's current coordinates are retrieved in



real-time using GPS. The estimated distance was determined using the technique and overlaid on the backdrop of the Google map.

Hybrid charging sources solar/wind/diesel systems are modeled present the design of a charging station for electric cars. This station contains a Photovoltaic (PV) module and Wind generation system, with three unidirectional converters circuits, the main objective of this design is to establish a charging station that gives charging priority set concerning the (SOC) level of EVs battery. If the available power from wind and solar energy is sufficient, charging is carried out by them and when demand increases are extracted from the Diesel at peak load time and use the grid at baseload time processing is done by Raspberry Pi controller, monitoring and control done by using Internet of Things IoT as shown in **Figure 6** [23].

A (PV) system, wind energy, and a diesel generator are all part of the planned system. The AC-DC converter connects the wind to the DC bus. The greatest power from the wind is tracked using a Maximum power point tracking (MPPT) controller. The Genetic Algorithm is used to perform wind MPPT. The PV system is linked to the DC bus through a DC-DC converter. MPPT is performed in the PV system using a modified Perturbation and observation (P & O) algorithm. Through the AC-DC converter depicted in **Figure 4**, the diesel generator is also linked to the DC bus. And the Raspberry Pi controller is used to perform control operations. **Figure 7** shows the block diagram.

**Figure 5** demonstrates the idea of a control function Voltage and current sensors are used to measure the voltage and current of Wind, Solar, EVs, and the Grid. The power value is calculated by converting the voltage and current numbers. The controller receives the voltage from all of the EVs' batteries. The customer's SELL and BUY options are obtained through the use of a touch LED

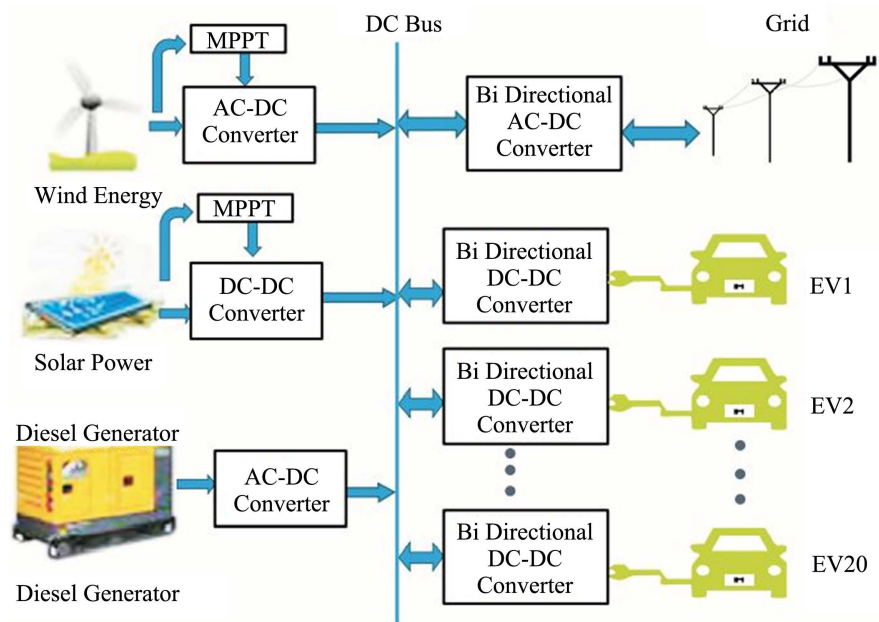

**Figure 6.** Suggested a solar/wind/diesel-powered charging station.

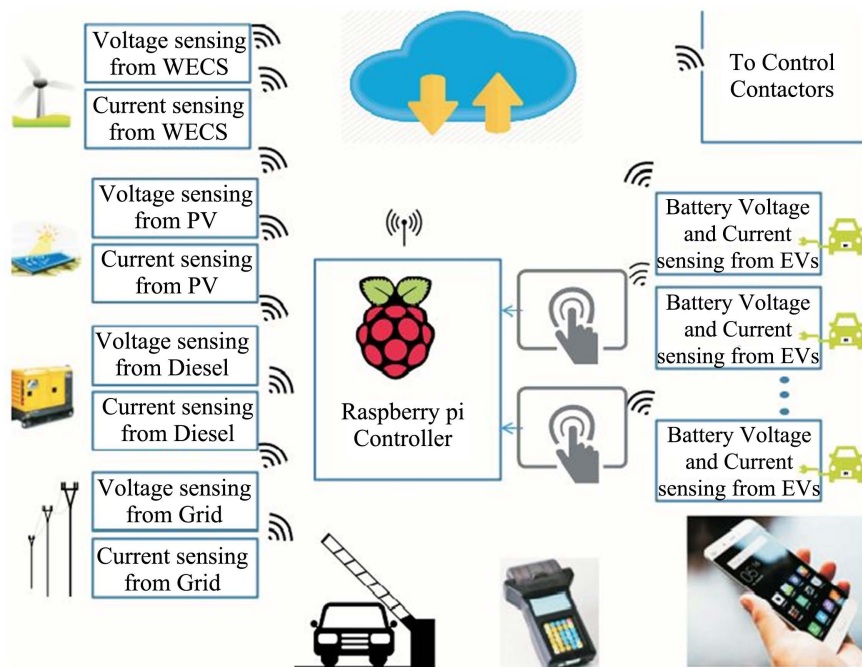

**Figure 7.** Suggested control functions using raspberry pi with IoT.

display. The data is all saved on the cloud. IoT technology handles all communications.

In [24], the proposed concept is intended to replace the original Wireless sensor network (WSN) and Radio-frequency Identification (RFID) system in parking garages with ZigBee technology. Due to its fast and safe functioning, RFID technology is utilized to check-in and out of cars. The system has two sections: one for monitoring and the other for control. The sensor, processing, and display devices are all found in the control portion. Sensor nodes, LED displays, and the information and controlling center are in that order. The system's key component is the last information and management center. In the hardware section, there are ARM7/LCP2148 controlled ZigBee communication modules. The LCD panel with reflection sensors, Kiel micro vision, flash magic, and express PCB are the software utilized. [25] has created a centralized electric vehicle (EV) recharging scheduling system for parking lots. This approach is based on a realistic vehicle parking pattern that emphasizes individual parking spaces. It divides electric vehicles into two categories based on their mobility. There are two types of EVs: regular and irregular. Electric vehicles require adequate charging time. This study proposes a PLRS system that tracks vehicle arrival and departure times, battery condition, and distance traveled. The system then creates its own charging timetable for EVs. This technology operates both during the day and at night. This technique helps to boost both the number of recharged Electric Vehicles and parking lot income. The proposed system uses a two-layered PLRS system to recharge electric vehicles based on their parking habits. [26] presents an IoT-based cloud-integrated smart parking solution. This suggested smart parking system is based on IoT module creation on-site. One of the most

practical Smart City concepts is the Internet of Things. This Internet of Things concept is used to monitor and give information regarding parking spot availability. It also offers a smartphone application that gives users information about parking spot availability. This smartphone application allows users to reserve a parking spot. Sensors such as infrared, passive infrared (PIR), and ultrasonic sensors are used to operate parking systems. Raspberry Pi is the processing device that communicates with the cloud and the sensor. The mobile application serves as a bridge between the system and the user. This application was created using the JavaScript programming language and the Apache Cordova and Angular Js framework. All data is stored on the IBM MQTT cloud server. This technology provides real-time information on the availability of parking spaces in the parking lot. Induction or magnetic coupling techniques are appropriate ways in WPT for EV charging, according to [27]. An intelligent WPT system is presented and simulated in this work to charge electric vehicles. Because misalignment limits the charging process, a novel solution is necessary to increase the flexibility of EV wireless charging. This system uses the finger print method to automatically align the transmitting and receiving coils. The proposed system is capable of saving necessary time, minimizing human errors, conserving energy, and charging cars based on real-time system information. For EV users, it is extremely helpful in terms of energy savings and reduced electricity costs. Wireless power transmission is a new field of development for EV charging. This study discusses strategies to increase wireless charging performance for high-frequency and high-power applications, as well as the efficiency of resonant inductive coupling for EV charging. Various coil alignment approaches were reviewed, with the fingerprint method being proposed as a cost-effective way to create WPT intelligent. Smart cities are being developed in recent years, with IoT playing a key role. IoT can solve issues including traffic congestion, auto parking shortages, and road safety. [28] presented a smart parking system based on IoT module creation on-site. This system keeps track of and analyzes parking space availability. Because all of the data created by this system is saved on the cloud, it is recognized as the ideal platform for IoT. The cloud's flexibility allows it to add and delete data from IoT systems in real time. Microcontroller, IR sensor, mobile application, buzzer, LED, and LCD display are included in the suggested system. [29] presents another method to the problem of EV charging scheduling. This study investigates a billing dilemma in a parking garage that requires complete utilization of time. When an electric vehicle enters at the garage's entry, it collects data such as arrival time, advised departure time, current and necessary battery SOCs, and the charging management system of the garage (CMS). This CMS is capable of deciding whether or not to accept or reject a customer's billing request. Based on the choice, it manages the needed power supply. It turns off the power when the process is finished. An intelligent charging network controls all of the charging units. CMS is in charge of the power supply, and all charging actions are switched automatically. EVs whose charging service is rejected by the system are parked in the non-charging zone. [30] gave a brief over-

view of wireless charging technologies. EVs, according to this report, will make energy a big aspect of transportation. Wireless charging, on the other hand, plays a vital part in EV charging since it provides an efficient and flexible method of charging. Furthermore, standardization of this technology is in the works, allowing for greater flexibility and freedom in charging vehicles in any wirelessly enabled parking spot. [31] gave an overview of the smart parking system. The proposed system includes a smart parking system, which is an onsite deployment of a slot model that is used to monitor available parking spaces and reserve a spot. Smart parking may boost the economy by lowering city pollution and fuel use. One of the IoT applications that might be explored is smart parking. It also allows you to reserve time slots. When he enters the slot, the time period begins. When the user exits the slot, he must pay the amount for the time he parked his automobile in the slot.

In [32], it presents the smart parking system method. The system includes an ultrasonic sensor, an Arduino Uno, an ESP8266-01 Wi-Fi module, and a cloud server ThingSpeak. This Internet of Things-based parking technology can link and analyze real-time data. This technology generates data and executes smart parking on its own. An ultrasonic sensor detects the availability of open space. The sensor is linked to an Arduino module that connects to a Wi-Fi network. The Arduino Uno connects to a cloud server over the internet and uploads data to it. Because the Android app is working by a software system, users must install it on their smartphones. This application may be used to reserve a parking place if one is required.

In [33], two types of wireless electric car charging systems, static and dynamic. Because of its simplicity, dependability, and user-friendliness, wireless charging offers several benefits over plug-in charging. The drawback is that it can only be used when the car is stationary, such as when parking. In [34], an integrated model system for both wireless charging (WC) and static charging (SC) facilities in a transportation network, with highlighting on the growth of wireless power transfer (WPT) technology. The best location for WC facilities poses greater design and operating challenges than static charging stations. However, in terms of the organization modeling technique used to locate these charging stations, they are similar in the main aim to maximize network traffic while lowering total system costs. A variety of modeling approaches for assessing the network and locating charge entities for SC and WC facilities are available. The technology's economic viability is critical for effective system integration and overall system performance.

In [35], the growing number of electric vehicles (EVs) necessitates the construction of additional charging infrastructure. Wireless charging is more efficient than plugs and wires. The essential idea which is often employed in wireless charging is based on resonant inductive power transmission, as the number of (EVs) grows, it is necessary to address issues that arise. Battery exchange, conductive charging, and WC transfer are the three types of charging methods available. Nowadays, the electric vehicle sector is growing at a fast pace through-

out the globe, resulting in a wide range of charging facilities on the market. However, due to a lack of full and severe standards, wireless power transfer still faces significant challenges.

In [36], the IoT-based vehicle tracking system, the NODE MCU ESP8266, GPS module, DHT11, buzzer, and power supply are all included in this setup. With a precision of 10 meters, the suggested technology is utilized to locate and navigate the vehicle. The technology tracks the position of a specific car and provides data to the user's mobile phone. The received data, in the form of latitude and longitude, is utilized to locate the car on Google Maps, and the output may also be seen on an Android phone via the Blynk App. The block diagram of the Vehicle Tracking System is shown in **Figure 8**. The GPS receiver and Esp8266 module were used in this project. The Blynk program is used to connect the phone to the PC. As a result, the GPS will provide the longitudinal and altitude information associated with the vehicle's position to Node MCU Esp8266. When the device connects to Wi-Fi, the data is then sent to the Esp8266, which controls the data. It estimates the closest vehicle's latitude and longitude, as well as its speed. It also displays the vehicle's location on a map.

In [37], renewable and non-renewable energy sources based are used to supply the charging station for electric cars this is done by providing a set of batteries inside the station that provides the EVs with the required charge by using DC-DC instead of using AC-DC because there are losses in the conversion process that are in the form of heat as It reduces the efficiency of the station's work and increases the time required for charging. All details of energy consumption and charging cost are monitored through using Arduino Uno controller and an application using IoT.

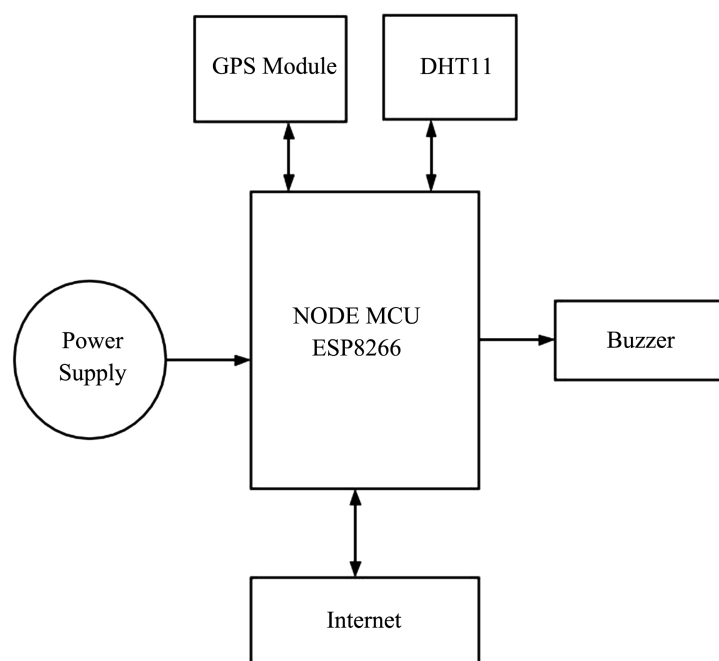

**Figure 8.** Diagram of vehicle tracking system.

IoT technology-based electric vehicles are introduced in [38] to monitor battery consumption and life. Monitoring is done via the internet using Thing Speak (day-by-day). These online data results were processed using MATLAB after an effective boosting algorithm is integrated with the objective function. The efficiency of this method is tested through visual analysis, and the results show an improved performance of vehicles, as it was noted that the cost of implementation decreased and the capacity of vehicles increased by 74.3% after monitoring by sensors. [39] effectively aims to make a charging station for electric vehicles that operates on a wireless charging system and enables the users to monitor the battery status and the battery charge level continuously using IoT technology. The authors in [40] utilize a solar panel to charge an E-vehicle module. IoT device was used to monitor the availability of maximum power, and a maximum power point tracker (MPPT) controller is used to track the solar's maximum power output. Proteus software was used to create the simulation model. The entire arrangement is linked to an Arduino UNO R3, and the battery level, as well as the quantity of battery created and distributed, is shown on an LCD. A GSM modem is utilized to receive an alarm message in the event of a power loss in the system. A website was included to verify the SOC status, the amount of power supplied to the charging the electric vehicle, and the charging station's available location the webpage is prepared using the HTML method.

The state of charge (SOC) of a battery pack must be accurately estimated online by the battery management system (BMS). This calculation is difficult, especially after a long period of battery use. To overcome this issue, a fuzzy-improved extended Kalman filter (fuzzy-IEKF) for Li-ion cells, independent of their age, to estimate the SOC of Li-ion battery packs are used. This paper suggested a fuzzy IEKF approach for estimating SOC for a battery pack throughout a charging/discharging cycle. The earliest phases of this strategy employed a fuzzy operator to predict SOC. This method updates the model for each individual cell in the battery pack using an adaptive model algorithm [41].

In [42], an enhanced deep neural network (DNN) technique for electric car applications to estimate the state of charge (SOC) of a Li-ion battery. A DNN with a sufficient number of hidden layers is capable of predicting the SOC of unseen drive cycles. To study the relative performance when assessed on different driving cycles, a set of DNN models with varied numbers of hidden layers and their training procedure had created. Increasing the number of hidden layers in DNN lowers the error rate can improve SOC estimation. Beyond that, increasing the hidden layer raises the mistake rate. It had been found that a four-layer DNN trained on the dynamic stress test (DST) drive cycle could predict the SOC values for other unseen drive cycles such as the federal urban driving schedule (FUDS), Beijing dynamic stress test (BJDST), and supplemental federal test procedure (US06) with surprising accuracy. Additional works using the Data-Driven estimating approach to estimate the SOC Traditional machine learning techniques are commonly used, such as support vector machines (SVM) and artificial neural networks (ANN). Based on adaptive unscented Kal-



man filters (AUKF) and least square support vector machines (LSSVM), a highly accurate technique for lithium polymer battery SOC calculation is developed.

To properly create the battery model with limited initial training data, a new strategy employing the moving window method is used in conjunction with AUKF and LSSVM. According to simulation and testing findings, the suggested method can predict lithium battery SOC with a small number of initial training samples. The proposed approach can predict lithium battery SOC with a small number of initial training samples [43].

The state of charge (SOC) of lithium-ion batteries is estimated using an artificial neural network (ANN) based on an inclusive equivalent circuit model. The neural network is utilized to predict the uncertainties in the battery model continuously. The battery's SOC is then estimated using a radial basis function neural network-based nonlinear observer. It is shown that the SOC estimate fault is finally constrained and the error bound may be arbitrarily reduced using Lyapunov stability analysis (the Lyapunov direct technique gives a highly effective methodology to assess the stability of nonlinear systems) [44]. By comparing the extended Kalman filter's SOC estimation performance with the suggested radial basis function neural network-based nonlinear observer. The suggested method is more precise and has a faster convergence speed [45].

A (BMS) monitors and controls the Li-ion battery, assessing charge estimate, health expectation, temperature control, charge equalization, protection, and optimal energy and power usage [46]. The battery management system (BMS) in control and monitoring charge and discharge of the battery introduce in [47] BMS determined the power, stat of Charge (SoC), State of Health (SoH), and temperature depending on the measurement Lithium-Ion batteries are used in both types (EV) and Hybrid Electric Vehicle (HEV) because of the numerous benefits it has over other types of batteries but they need BMS to guarantee the battery's safe operation during its charging/discharging cycle. IoT was used successfully to collect this information from the various sensor to estimate current flow, power charge/discharge additionally the Depth of Discharge (DOD) also discuss various types of wireless technologies that are used for observing the battery system.

In [48], multiple approaches exist nowadays to estimate the SOC of EV batteries. Some of the methods focus on battery SOC estimation and the concerns and challenges that come with it. Also, it is conducted on the core technologies of lithium-ion battery state estimate techniques for electric cars, which are classified into five groups: conventional method, adaptive filter algorithm, learning algorithm, nonlinear observer, and hybrid method. The most significant aspects that impact the accuracy and robustness of SOC calculation are lithium-ion battery characteristics, battery model, estimation technique, and cell unbalancing [49]. Due to economic costs aspects, electric cars should be able to drive the most distance on a single charge by monitoring and utilizing the maximum energy from the battery pack while preserving battery life. When the vehicle is



subjected to demanding real-time con, such as fast acceleration and braking, a trustworthy monitoring system minimizes the user's expectation of battery life. The charging system should have a low-cost, low-power, highly reliable, redundant, and scalable technique for monitoring rechargeable Li-ion batteries using wireless communication architecture.

In [50], to search for a charging station and slot availability, extra time will be lost and annoyance will arise. Thus, it's important for the Evs to be equipped with a system for saving time and avoiding discomfort for EV users. This method should display the number of charge slots available at each charging station along the trip route. Also, it can be used to display the time the car is connected to the charging station, allowing us to plan our travel accordingly. At peak times, the world's must has high penetration of electric vehicles places an additional strain on the power infrastructure. Smart Charging Station is used for domestic applications to solve this problem. At peak times, Grid-connected PV generation successfully handles the power necessary to charge Electric Vehicles, and Electric Vehicles also operate as an Uninterrupted Power Supply (UPS) depending on the Time of Use (TOU) Tariff. The Raspberry Pi controller is in charge of all control operations. The Internet of Things was used to monitor and manage the entire operation. In MATLAB/SIMULINK [51] [52], a real-time server-based forecasting application: 1) to offer schedule management to prevent waiting; and 2) to provide a real-time CS suggestion for EVs with low costs and shorter charging times. Without the need for a sophisticated information environment, the created application can warn the EV driver when charging is necessary, detect the nearby CSs with names, locations, and geographical route coordinates, and reserve the slot to charge the EV to reach the destination. The data necessary for the algorithm does not require any complex information exchange because all information can be retrieved automatically utilizing publically available websites via GPS and the mobile internet system with only a little input from the driver.

### 3. Difficulties and Problems

It is necessary to move to the use of electric vehicles, as they contribute to reducing environmental pollution, and for the development and improvement of this sector, the Internet of things must be used because it contributes to making the use of this type of vehicle for the user easier and also contributes to the ease of finding charging stations, as well as making the management of charging stations more organized and easy, but We have faced some challenges in using the wireless charging system in parking lots, and to make the system more efficient, some challenges must be taken into consideration:

- The system must be resistant to environmental conditions such as rain, dust, fog, etc.;
- Ensuring the continuous communication of the parts of the system with each other, providing communication networks with sufficient coverage area, and

- ensuring communication in various environmental conditions;
- Make the system able to process large data as quickly and without delay;
- Wireless charging lacks uniformity;
- Choose IoT devices carefully to reduce maintenance costs.

**Table 1.** Comparison of a set of reference papers.

Reference	Merits	Demerits
[20]	Bookings are made using a smartphone application. Secure	Expensive, difficult to comprehend
[24]	It contains slot information. It is compatible with the existing parking system.	High price. Implementation will take more time.
[25]	The system creates its own charging timetable for electric vehicles.	There is no chargeable data creation.
[26]	Bookings are made using a smartphone application. GPS use	The issue with data uploading
[32]	Automatic data generation using mobile application	aNo safety against a variety of environmental factors
[28]	Because of the cloud's flexibility, data may be added or withdrawn.	Overloading the microcontroller might cause the entire system to crash.
[29]	usage of a charge management system (CMS)	There is no mobile application.
[33]	Wireless charging is more convenient and efficient than using a plug-in. For high-powered applications.	Only in stationary modes is it used.
[30]	It provides an effective and adaptable way to charge electric vehicles.	Wireless charging lacks standardization.
[31]	Parking spots can be reserved.	There is no usage of GPS. No data to upload

#### 4. Conclusion

In terms of the problem of lack of fuel and environmental pollution to reduce pollution as well as fuel consumption, we have to use electric vehicles to contribute to the spread of the use of electric vehicles. Charging stations must be provided so the user has easy access to the charging station, especially in our time when the Internet service is available and Internet of things technology is used to display the locations of the available charging stations, which reduces the time to reach them. The state of charge (SOC) of a battery pack must be accurately estimated online by the battery management system (BMS). This calculation is dif-

difficult, especially after a long period of battery use. To overcome this issue, Data-Driven estimating approach to estimate the SOC is used and traditional machine learning techniques are commonly used such as support vector machine (SVM), fuzzy controller, and artificial neural network (ANN). Since SOC represents the amount of energy available inside the battery, the SOC is displayed by using an application to reduce power consumption and extend battery life. Charging the battery needs time to reduce the loss of time in the charging process. It is suggested to put stations inside the park to take advantage of the shopping time of charging the electric vehicles. Various sources of charging inside the charging stations such as solar energy and wind energy can also be used as the main electricity grid. Also, this review paper contains table of comparison of various research paper as shown in **Table 1**.

### Conflicts of Interest

The authors declare no conflicts of interest.

### References

- [1] Manshadi, S.D., Khodayar, M.E., Abdelghany, K. and Uster, H. (2018) Wireless Charging of Electric Vehicles in Electricity and Transportation Networks. *IEEE Transactions on Smart Grid*, **9**, 4503-4512. <https://doi.org/10.1109/TSG.2017.2661826>
- [2] Subudhi, P.S. and Krithiga, S. (2020) Wireless Power Transfer Topologies Used for Static and Dynamic Charging of EV Battery: A Review. *International Journal of Emerging Electric Power Systems*, **21**, Article ID: 20190151. <https://doi.org/10.1515/ijeeps-2019-0151>
- [3] Rana, M.M., Xiang, W., Wang, E., Li, X. and Choi, B.J. (2018) Internet of Things Infrastructure for Wireless Power Transfer Systems. *IEEE Access*, **6**, 19295-19303. <https://doi.org/10.1109/ACCESS.2018.2795803>
- [4] Arif, S.M., Lie, T.T., Seet, B.C., Ayyadi, S. and Jensen, K. (2021) Review of Electric Vehicle Technologies, Charging Methods, Standards and Optimization Techniques. *Electronics*, **10**, Article 1910. <https://doi.org/10.3390/electronics10161910>
- [5] Dost, P., Spichartz, P. and Sourkounis, C. (2015) Charging Behaviour of Users Utilising Battery Electric Vehicles and Extended Range Electric Vehicles within the Scope of a Field Test. 2015 *International Conference on Renewable Energy Research and Applications*, Palermo, 22-25 November 2015, 1162-1167. <https://doi.org/10.1109/ICRERA.2015.7418592>
- [6] Hannan, M.A., Hoque, M.M., Hussain, A., Yusof, Y. and Ker, P.J. (2018) State-of-the-Art and Energy Management System of Lithium-Ion Batteries in Electric Vehicle Applications: Issues and Recommendations. *IEEE Access*, **6**, 19362-19378. <https://doi.org/10.1109/ACCESS.2018.2817655>
- [7] Gholizadeh, M. and Salmasi, F.R. (2014) Estimation of State of Charge, Unknown Nonlinearities, and State of Health of a Lithium-Ion Battery Based on a Comprehensive Unobservable Model. *IEEE Transactions on Industrial Electronics*, **61**, 1335-1344. <https://doi.org/10.1109/TIE.2013.2259779>
- [8] Florea, B.C. and Taralunga, D.D. (2020) Blockchain IoT for Smart Electric Vehicles Battery Management. *Sustainability*, **12**, Article 3984. <https://doi.org/10.3390/su12103984>

- [9] Sun, F. and Xiong, R. (2015) A Novel Dual-Scale Cell State-of-Charge Estimation Approach for Series-Connected Battery Pack Used in Electric Vehicles. *Journal of Power Sources*, **274**, 582-594. <https://doi.org/10.1016/j.jpowsour.2014.10.119>
- [10] Iclodean, C., Varga, B., Burnete, N., Cimerdean, D. and Jurchiș, B. (2017) Comparison of Different Battery Types for Electric Vehicles. *IOP Conference Series: Materials Science and Engineering*, **252**, Article ID: 012058. <https://doi.org/10.1088/1757-899X/252/1/012058>
- [11] Wei, J., Dong, G. and Chen, Z. (2018) Lyapunov-Based State of Charge Diagnosis and Health Prognosis for Lithium-Ion Batteries. *Journal of Power Sources*, **397**, 352-360. <https://doi.org/10.1016/j.jpowsour.2018.07.024>
- [12] Lu, L., Han, X., Li, J., Hua, J. and Ouyang, M. (2013) A Review on the Key Issues for Lithium-Ion Battery Management in Electric Vehicles. *Journal of Power Sources*, **226**, 272-288. <https://doi.org/10.1016/j.jpowsour.2012.10.060>
- [13] Plett, G.L. (2015) Battery Management Systems, Volume I: Battery Modeling. Artech House, Norwood, MA.
- [14] Kanagachidambaresan, G.R., Anand, R., Balasubramanian, E. and Mahima, V., Eds. Internet of Things for Industry 4.0 EAI/Springer Innovations in Communication and Computing. <http://www.springer.com/series/15427>
- [15] Lin, C., Mu, H., Xiong, R. and Cao, J. (2017) Multi-Model Probabilities Based State Fusion Estimation Method of Lithium-Ion Battery for Electric Vehicles: State-of-Energy. *Applied Energy*, **194**, 560-568. <https://doi.org/10.1016/j.apenergy.2016.05.065>
- [16] Atzori, L., Iera, A. and Morabito, G. (2010) The Internet of Things: A Survey. *Computer Networks*, **54**, 2787-2805. <https://doi.org/10.1016/j.comnet.2010.05.010>
- [17] Ledwaba, L.P.I. and Hancke, G.P. (2020) IoT Security. In: Shen, X., Lin, X. and Zhang, K., Eds., *Encyclopedia of Wireless Networks*, Springer, Cham, 681-685. [https://doi.org/10.1007/978-3-319-78262-1\\_291](https://doi.org/10.1007/978-3-319-78262-1_291)
- [18] Obaidat, M.S., Traore, I. and Woungang, I. (2018) Biometric-Based Physical and Cybersecurity Systems. Springer, Cham. <https://doi.org/10.1007/978-3-319-98734-7>
- [19] Cerullo, G., Mazzeo, G., Papale, G., Ragucci, B. and Sgaglione, L. (2018) IoT and Sensor Networks Security. In: *Security and Resilience in Intelligent Data-Centric Systems and Communication Networks*, Academic Press, Cambridge, MA, 77-101. <https://doi.org/10.1016/B978-0-12-811373-8.00004-5>
- [20] Timpner, J. and Wolf, L. (2012) A Back-End System for an Autonomous Parking and Charging System for Electric Vehicles. 2012 *IEEE International Electric Vehicle Conference*, Greenville, SC, 4-8 March 2012, 1-8. <https://doi.org/10.1109/IEVC.2012.6183267>
- [21] Bedogni, L., Bononi, L., D'Elia, A., Di Felice, M., Rondelli, S. and Cinotti, T.S. (2014) A Mobile Application to Assist Electric Vehicles' Drivers with Charging Services. 2014 *8th International Conference on Next Generation Mobile Applications, Services and Technologies*, Oxford, UK, 10-12 September 2014, 78-83. <https://doi.org/10.1109/NGMAST.2014.49>
- [22] Anuradha, P. and Sendhilkumar, R. (2011) Design and Implementation of Zigbee-RFID Based Vehicle Tracking. *International Conference on Sustainable Energy and Intelligent Systems*, Chennai, 20-22 July 2011, 689-694. <https://doi.org/10.1049/cp.2011.0451>
- [23] Divyapriya, S., Amudha, A. and Vijayakumar, R. (2018) Design and Implementation of Grid Connected Solar/Wind/Diesel Generator Powered Charging Station for Electric Vehicles with Vehicle to Grid Technology Using IoT. *Current Signal*

- Transduction Therapy*, **13**, 59-67.  
<https://doi.org/10.2174/1574362413666180226111921>
- [24] Patil, M. and Bhonge, V. (2013) Wireless Sensor Network and RFID for Smart Parking System. *International Journal of Emerging Technology and Advanced Engineering*, **3**, 188-192.  
<http://citeseerx.ist.psu.edu/viewdoc/download?doi=10.1.1.413.7821&rep=rep1&type=pdf>
- [25] Kuran, M.S., Carneiro Viana, A., Iannone, L., Kofman, D., Mermoud, G. and Vas-seur, J.P. (2015) A Smart Parking Lot Management System for Scheduling the Re-charging of Electric Vehicles. *IEEE Transactions on Smart Grid*, **6**, 2942-2953.  
<https://doi.org/10.1109/TSG.2015.2403287>
- [26] Khanna, A. and Anand, R. (2016) IoT Based Smart Parking System. 2016 *International Conference on Internet of Things and Applications*, Pune, India, 22-24 January 2016, 266-270. <https://doi.org/10.1109/IOTA.2016.7562735>
- [27] Sultanbek, A., Khassenov, A., Kanapyanov, Y., Kenzhagaliyeva, M. and Bagheri, M. (2017) Intelligent Wireless Charging Station for Electric Vehicles. 2017 *International Siberian Conference on Control and Communications*, Astana, 29-30 June 2017, 1-6. <https://doi.org/10.1109/SIBCON.2017.7998497>
- [28] Fatima, N., Natkar, A., Jagtap, P. and Choudhari, S. (2018) IOT Based Smart Car Parking System for Smart Cities. *International Journal of Advance Research, Ideas and Innovations in Technology*, **4**, 554-556.
- [29] Wei, Z., Li, Y., Zhang, Y. and Cai, L. (2018) Intelligent Parking Garage EV Charging Scheduling Considering Battery Charging Characteristic. *IEEE Transactions on Industrial Electronics*, **65**, 2806-2816. <https://doi.org/10.1109/TIE.2017.2740834>
- [30] Kesler, M. (2019) Wireless Charging of Electric Vehicles. 2018 *IEEE Wireless Power Transfer Conference*, Montreal, QC, 3-7 June 2018, 1-4.  
<https://doi.org/10.1109/WPT.2018.8639303>
- [31] Anusha, A.M.S., Anushri, G.B. and Hegde, M.D. (2019) Review Paper on Smart Parking System. *International Journal of Engineering Research & Technology*, **7**, 1-3.
- [32] Gupta, A., Kulkarni, S., et al. (2017) Smart Car Parking Management System Using IoT. *American Journal of Science, Engineering and Technology*, **2**, 112-119.
- [33] Panchal, C., Stegen, S. and Lu, J. (2018) Review of Static and Dynamic Wireless Electric Vehicle Charging System. *Engineering Science and Technology*, **21**, 922-937.  
<https://doi.org/10.1016/j.jestch.2018.06.015>
- [34] Majhi, R.C., Ranjitkar, P., Sheng, M., Covic, G.A. and Wilson, D.J. (2021) A Systematic Review of Charging Infrastructure Location Problem for Electric Vehicles. *Transport Reviews*, **41**, 432-455. <https://doi.org/10.1080/01441647.2020.1854365>
- [35] Niu, S., Xu, H., Sun, Z., Shao, Z.Y. and Jian, L. (2019) The State-of-the-Arts of Wireless Electric Vehicle Charging via Magnetic Resonance: Principles, Standards and Core Technologies. *Renewable and Sustainable Energy Reviews*, **114**, Article ID: 109302. <https://doi.org/10.1016/j.rser.2019.109302>
- [36] Htwe, H.N., Mon, Z.Z., Mya, A. and Aung, M. (2019) Design and Implementation of IOT Based Vehicle Tracking System. *International Journal of Science, Engineering and Technology Research*, **8**, 374-379.  
[https://www.academia.edu/42909622/Design\\_and\\_Implementation\\_of\\_IOT\\_Based\\_Vehicle\\_Tracking\\_System](https://www.academia.edu/42909622/Design_and_Implementation_of_IOT_Based_Vehicle_Tracking_System)
- [37] Muralikrishnan, P. and Kalaivani, M. (2020) IOT Based Electric Vehicle Charging Station Using Arduino Uno. *International Journal of Advanced Science and Tech-*

- nology*, **29**, 4101-4106.
- [38] Urooj, S., Alrowais, F., Teekaraman, Y., Manoharan, H. and Kuppusamy, R. (2021) IoT Based Electric Vehicle Application Using Boosting Algorithm for Smart Cities. *Energies*, **14**, Article 1072. <https://doi.org/10.3390/en14041072>
- [39] Muni, V., Pranav, A.S. and Srinivas, A. (2020) Iot Based Smart Battery Station Using Wireless Power Transfer Technology. *International Journal of Scientific & Technology Research*, **9**, 2876-2881.
- [40] Akila, A., Akila, E., Akila, S., Anu, K. and Elzalet, J. (2019) Charging Station for E-Vehicle Using Solar with IOT. 2019 *5th International Conference on Advanced Computing & Communication Systems (ICACCS)*, 785-791.
- [41] Sepasi, S., Roose, L.R. and Matsuura, M.M. (2015) Extended Kalman Filter with a Fuzzy Method for Accurate Battery Pack State of Charge Estimation. *Energies*, **8**, 5217-5233. <https://doi.org/10.3390/en8065217>
- [42] How, D.N.T., Hannan, M.A., Lipu, M.S.H., Sahari, K.S.M., Ker, P.J. and Muttaqi, K.M. (2020) State-of-Charge Estimation of Li-Ion Battery in Electric Vehicles: A Deep Neural Network Approach. *IEEE Transactions on Industry Applications*, **56**, 5565-5574. <https://doi.org/10.1109/TIA.2020.3004294>
- [43] Meng, J., Luo, G. and Gao, F. (2016) Lithium Polymer Battery State-of-Charge Estimation Based on Adaptive Unscented Kalman Filter and Support Vector Machine. *IEEE Transactions on Power Electronics*, **31**, 2226-2238. <https://doi.org/10.1109/TPEL.2015.2439578>
- [44] Liu, S., Jiang, W., Li, X. and Zhou, X.F. (2016) Lyapunov Stability Analysis of Fractional Nonlinear Systems. *Applied Mathematics Letters*, **51**, 13-19. <https://doi.org/10.1016/j.aml.2015.06.018>
- [45] Chen, J., Ouyang, Q., Xu, C. and Su, H. (2018) Neural Network-Based State of Charge Observer Design for Lithium-Ion Batteries. *IEEE Transactions on Control Systems Technology*, **26**, 313-320. <https://doi.org/10.1109/TCST.2017.2664726>
- [46] Cheng, K.W.E., Divakar, B.P., Wu, H., Ding, K. and Ho, H.F. (2011) Battery-Management System (BMS) and SOC Development for Electrical Vehicles. *IEEE Transactions on Vehicular Technology*, **60**, 76-88. <https://doi.org/10.1109/TVT.2010.2089647>
- [47] Sivaraman, P. and Sharmeela, C. (2020) IoT-Based Battery Management System for Hybrid Electric Vehicle. In: Chitra, A., Sanjeevikumar, P., Holm-Nielsen, J.B. and Himavathi, S., Eds., *Artificial Intelligent Techniques for Electric and Hybrid Electric Vehicles*, John Wiley & Sons, Inc., Hoboken, 1-16. <https://doi.org/10.1002/9781119682035.ch1>
- [48] Zhang, R., et al. (2018) State of the Art of Lithium-Ion Battery SOC Estimation for Electrical Vehicles. *Energies*, **11**, Article 1820. <https://doi.org/10.3390/en11071820>
- [49] Mathew, S.A., Prakash, R. and John, P.C. (2012) A Smart Wireless Battery Monitoring System for Electric Vehicles. 2012 *12th International Conference on Intelligent Systems Design and Applications (ISDA)*, 189-193.
- [50] Wang, J., Wang, C., Deng, H., Huang, H. and Li, L. (2020) Electric Vehicle Charging Detection and Early Warning System Based on Internet of Thing. 2020 *7th International Conference on Information, Cybernetics, and Computational Social Systems (ICCSS)*, 650-654.
- [51] Divyapriya, S., Vijayakumar, R., et al. (2018) Design of Residential Plug-In Electric Vehicle Charging Station with Time of Use Tariff and IoT Technology. 2018 *International Conference on Soft-Computing and Network Security (ICSNS)*, 1-5.

- [52] Savari, G.F., Krishnasamy, V., Sathik, J., Ali, Z.M. and Abdel Aleem, S.H.E. (2020) Internet of Things Based Real-Time Electric Vehicle Load Forecasting and Charging Station Recommendation. *ISA Transactions*, **97**, 431-447.  
<https://doi.org/10.1016/j.isatra.2019.08.011>