

# Galileo Receiver Core Technologies

Pavel Kovář, František Vejražka, Libor Seidl, Petr Kačmařík

Czech Technical University in Prague, Faculty of Electrical Engineering, Technická 2, 166 27 Prague 6, Czech Republic  
Tel: +420 2 2435 2244 Fax: Email: [kovar@fel.cvut.cz](mailto:kovar@fel.cvut.cz)

Received: 30 November 2004 / Accepted: 12 July 2005

**Abstract.** The modern satellite navigation system Galileo is developed by European Union. Galileo is a completely civil system that offers various levels of services especially for civil users including service with safety guarantee. Galileo system employs modern signal structure and modern BOC (Binary Offset Carrier) modulation. The Galileo Receiver is investigated in the frame of the GARDA project solved by consortium under leadership of Alenia Spacio – LABEN. The aim of Galileo Receiver Core Technologies subtask is to investigate the key problems of the Galileo receiver development. The Galileo code and carrier tracking subtask of the Galileo Receiver Core Technologies is carried out at the Czech Technical University. The problem was analysed and split to the particular tasks. The aim of this paper is focused on BOC correlator architecture. The correlation function of the BOC modulation is more complex with a plenty of correlation peaks. The delay discriminator characteristic of such signal has several stable nodes, which cause stability problem. The standard solutions of this problem like BOC non-coherent processing, very early – very late correlator and deconvolution correlator are analysed. The new correlator architecture for BOC modulation processing has been developed. The developed correlator has two outputs, one for fine tracking and the second one for correct node detection. The second output is based on comparison of the correlation function envelopes. The simplified method of correlation function envelope calculation is described in this paper. The correlator is planned to be tested in the GRANADA software simulator including a sophisticated method of correlator output combination.

**Key words:** Galileo, Galileo core technologies, Galileo receiver, code tracking, carrier tracking.

## 1. INTRODUCTION

### 1.1 Galileo

The European GNSS system Galileo (that is currently under development) operates on the same ranging principle as the existing GPS and GLONASS systems do. The big benefit of this system is that it is a completely civil system, which offers to the user various types of services, which are adjusted to the civil user requirements. Besides Open Service, which is free of charge, the system offers services with guarantee of the service performance by the system provider, customer driven local element services and Public Regulated Service for governmental needs.

Galileo shares the same basic operating principle with the GPS, but the system architecture and service model are based on the latest knowledge.

### 1.2 GARDA project

The basic architecture of the Galileo user receiver is similar to the GPS one, yet some approaches to the receiver design are more complex. Galileo receiver development is investigated within the GARDA (Galileo Receiver Development Activity) project, performed by a consortium established under the leadership of Alenia Spacio – LABEN. GARDA is funded by the GJU (Galileo Joint Undertaking) in the frame of the Galileo R&D activities under the EC 6<sup>th</sup> Framework Program. The project consists of three tasks, which cover Galileo user receiver development including development plan consolidation, software Galileo receiver development, receiver prototyping, and last, but not least, core technology task.

### 1.3 GRANADA

GRANADA (Galileo Receiver ANalysis And Design Application) is the software simulator of the Galileo developed in the frame of GARDA project by Deimos Space company. Software simulator consists of Bit-True GNSS SW Receiver Simulator and GNSS Environment and Navigation Simulator.

Mono-channel Bit-True GNSS SW Receiver Simulator serves for detail analyses of the Galileo signal processing, signal propagation, multipath propagation, interference, and other related problems. Bit-true simulator is based on detail modelling of the signal processing inside the Galileo receiver.

On the other hand, the Environment and Navigation Simulator is determined for analyses of the position determination algorithms, satellites constellation etc. The macro model of the receiver behaviour, propagation channel, noise, etc. are employed in this simulator.

The only basic most common features and algorithms of the Galileo receiver are implemented to the simulator. Some marginal problems of the Galileo are simplified or not implemented.

### 1.4 Galileo Core Technologies

The aim of the core technologies subtask is to investigate the critical principles and technologies of the Galileo system. The technologies are to be tested with the GRANADA software simulator. The other goal of the core technology task is to implement the new features to the GRANADA software.

The Galileo receiver core technology task was launched in January, 2005, thus the current state of the task is the preliminary phase and the problem is being analysed. The analysis and preliminary experiments results of the Galileo receiver core technology are concentrated in this paper.

Two main Galileo core technologies have been assigned to the Czech Technical University:

- Galileo code tracking,
- Galileo phase tracking.

The present simulation results with GRANADA tool have mainly verification purpose. The fundamental problems like performance of tracking loops in presence of additive white Gaussian noise were analysed. The performance parameter (variance of tracking error in this case) was compared with theoretical assumptions with good agreement. This simulation also showed some weaknesses and inconveniences of GRANADA mainly

belong to impossibility to perform a multi frequency signal tracking.

## 2. PROBLEM ANALYSIS

The code and carrier tracking are very complex problems, which very closely relate to each other. The main function of the Galileo receiver is an estimation of the code delay and the carrier phase of the receiving signal. The estimation is usually realized by use of correlation reception principle, where the replica of the Galileo signal is synchronized with the received signal. The feedback tracking circuits are commonly used. The tracking loops can be classified to the following main categories:

1. Single frequency scalar tracking loops – individual tracking loops for each satellite signal
2. Multicarrier scalar tracking loops – complex tracking loops for all signals of individual satellite
3. Multicarrier vector tracking loop (VDLL) – one complex tracking loop for all signal components of all satellites

The other classification criterion of the signal tracking methods is according to interaction of the code and carrier tracking:

1. Independent code tracking and carrier tracking
2. Independent carrier tracking and code tracking with carrier aided
3. Integrated (joined) code and carrier tracking

The last classification approach to the code and phase tracking is according to the design principle of the loop low pass feedback filter:

- a) Deterministic approach (classical control filter),
- b) Stochastic approach (Wiener or Kalman filter).

The problem can be analyzed according to many other criteria. Basically code and carrier tracking is very similar to the GNSS signal tracking, but several problems arise in consequence with higher Galileo signal complexity. This problem has been identified and some of them will be solved in the frame of core technology project. The identified particular problems are listed below:

1. BOC and AltBOC discriminator
  - a. Delay discriminator
  - b. Phase/Frequency discriminator
  - c. Detection of the correct peak of the correlation function

- d. Sensitivity of the discriminator to multipath
- 2. Cycle slip detection technique
- 3. Ambiguity resolution
- 4. Tracking strategy
  - a. Independent code tracking and carrier tracking
  - b. Independent carrier tracking and code tracking with carrier aided
  - c. Integrated (joined) code and carrier tracking
- 5. Tracking loops
  - a. Tracking loop development method
  - b. Dynamic performances of the tracking loops
  - c. Loop stability
- 6. Tracking strategy in environment with shadowing

In this early phase of Galileo development, the research is focused on the basic solution of most critical problems. The one of the key problem of the Galileo receiver is the processing of the ranging signal with BOC (Binary Offset Carrier) modulation. This problem is analyzed in the rest of this paper.

### 3. STANDARD GNSS CORRELATOR

The essential navigation receiver block for an estimation of the pseudorange is called correlator. The standard GNSS correlator is designed for BPSK modulated ranging signal. The adoption of the standard GNSS correlator for BOC modulated ranging signals is discussed in this paragraph.

The architecture of adopted delay correlator is very similar to the BPSK one, see Figure 1. The ranging code  $c(\lfloor Nf_0t \rfloor)$  and digital carrier  $\text{sgn}(\sin(2\pi Mf_0t))$  can be multiplied and the resulting code  $c_{M,N}(t)$  can be used for the despreading of the received signal.

$$c_{M,N}(t) = c(\lfloor Nf_0t \rfloor) \cdot \text{sgn}(\sin(2\pi Mf_0t)) \tag{1}$$

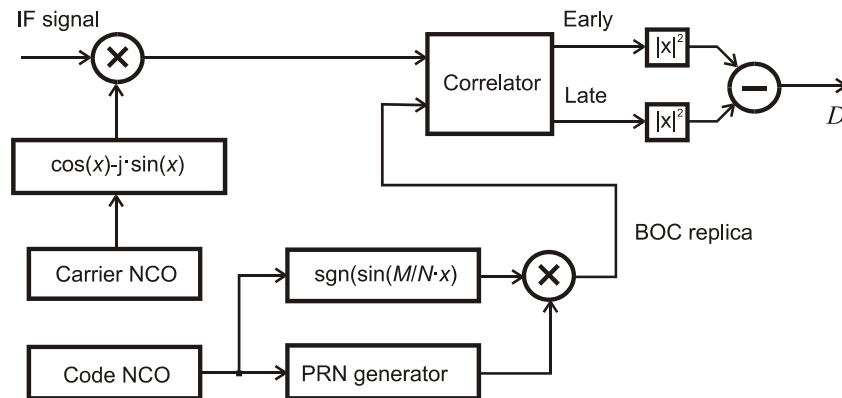

Figure 1. BOC correlator

The BOC delay discriminator characteristic of Early minus Late amplitude discriminator and Early minus Late power discriminator for BOC(1,1) modulation are displayed on the Figure 2.

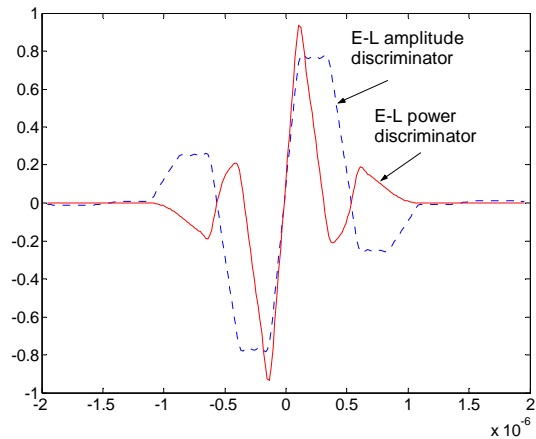

Figure 2. BOC(1,1) delay discriminator characteristic

The problem of the BOC correlator is in existence of more than one stable node on the discriminator characteristic, see Figure 3. The problem with multiple stable nodes is even more complicated for higher order BOC modulation, where a plenty of these nodes occur.

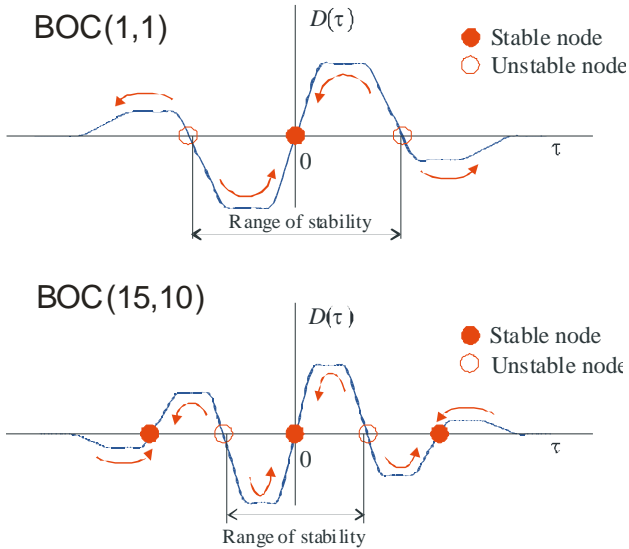

Figure 3. Stable and Unstable nodes of the BOC discriminator characteristics

The number of false stable nodes in coherent delay discriminator characteristic for modulation BOC(N, M) is given by

$$S = 2 \left\lfloor \frac{2N - 1}{2M} \right\rfloor. \tag{2}$$

This problem causes significant reduction of the range of the delay lock loop (DLL) stability. The DLL can potentially track false stable node without any indication.

Discussed problem is demonstrated by the following simulation, see Figure 4. The several experiments of the DLL hang-up stage are displayed on this figure. The initial delay error of each experiment is set to zero value. The DLL mostly tracks the correct node. Some of the experiments diverge to the false node or totally diverge due to the noise in loop.

False node tracking of BOC modulated signal is a very serious problem, which must be solved.

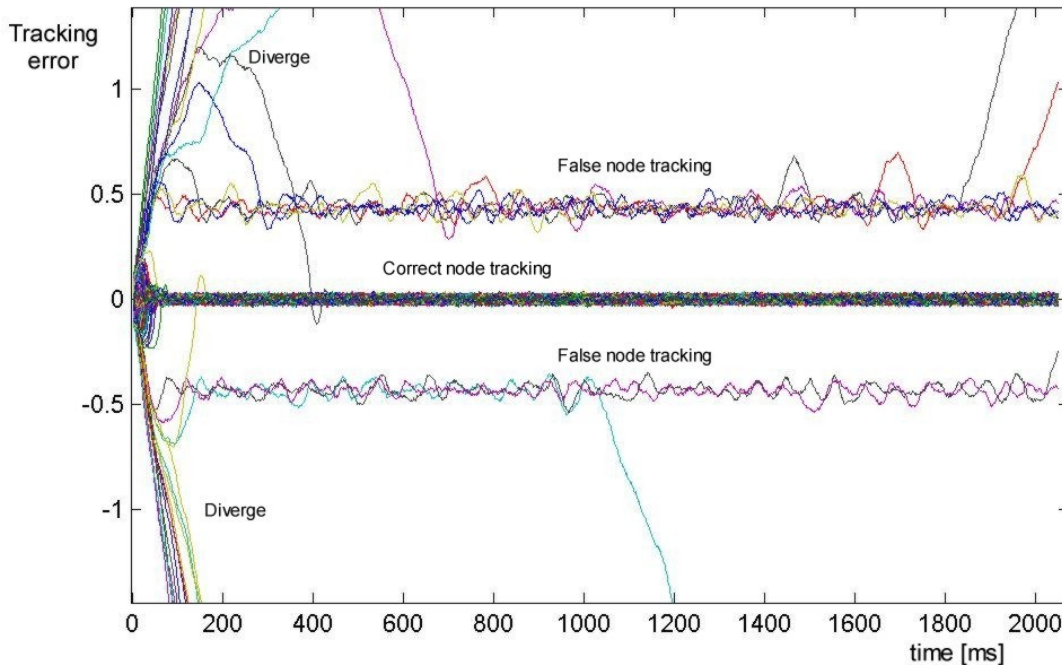

Figure 4. Simulation results of the tracking errors of BOC(1,1) signal by Early minus Late power correlator

4. EXISTING BOC CORRELATORS

4.1 Non-coherent BOC processing

Since the both sidebands of BOC modulation contain the same information the particular sideband can be

processed separately and result can be non-coherently combined, see Figure 5. Of course, this method is non optimal and does not use BOC modulation benefits. On the other hand, the particular sidebands can be easily processed in classical BPSK manner. The separate sideband processing can also be useful when one of the two sidebands is corrupted with interference.

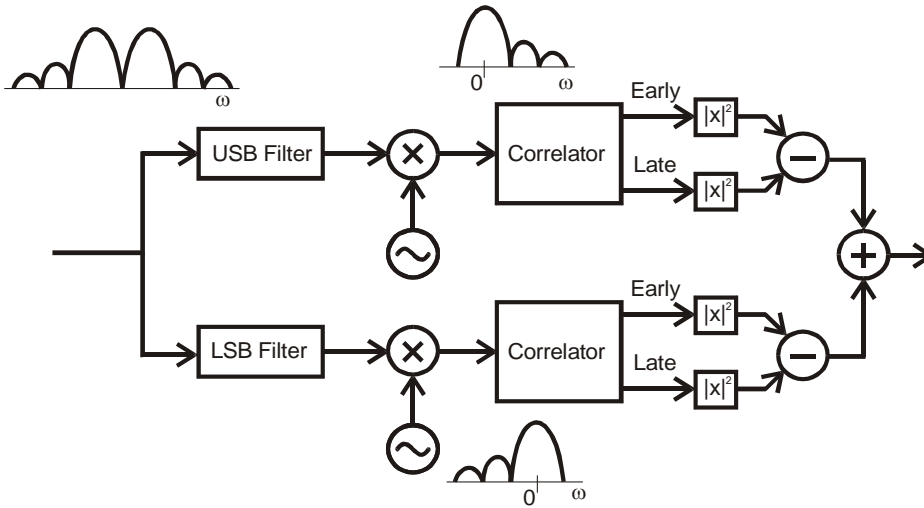

Figure 5. BOC non-coherent processing.

4.2 Very early – very late correlator

The most obvious way to handle the problem with tracking of correct peak of BOC modulation correlation

function is the technique denoted as very early – very late (VEVL) correlator, also known as “bump-jump” method, see Fine and Wilson (1999), Barker et al.(2002). In comparison to classical early – late correlator structure, VEVL has a further couple of early and late taps, see Figure 6. This extra couple of taps are adjusted to track the side-peaks of correlation function.

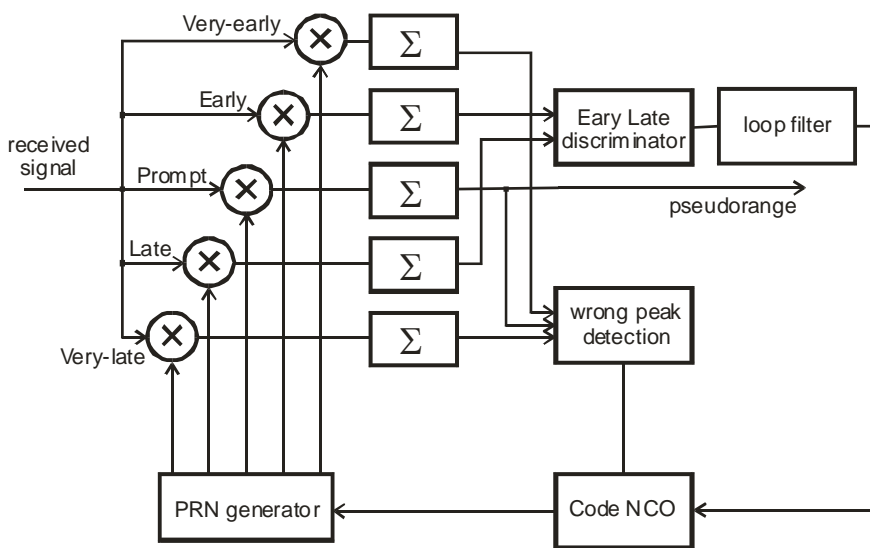

Figure 6. Structure of Very Early Very Late correlator.

The early and late taps together with prompt tap are intended for tracking the correct (centre) peak of the correlation function like in the classical early – late correlator. The spacing (a correlator width) is adjusted to enable tracking the narrow peak of particular type of BOC correlation function. The additional very early – very late taps are set to watch the side-peaks of the correlation function. When the correlator tracks the correct correlation function peak, the prompt tap output is greater than from very-early and very-late ones. In case of repetitively greater output from very-early or very-late taps, the wrong peak tracking is declared. Then the phase of a local signal replica is adjusted to restore the tracking of the correct peak.

### 4.3 Deconvolution correlator

This method is based on the linearization of discriminator characteristic (S-curve function) with using of multiple taps in the correlator structure, see Fante (2003). The discriminator characteristic of the classical no-coherent two taps early and late correlator (NCEL) is given by

$$S(\tau) = |R(\tau + D/2)|^2 - |R(\tau - D/2)|^2, \quad (3)$$

where  $R(\tau)$  is cross-correlation function,  $\tau$  is tracking error and  $D$  is the spacing between the early and late taps. The two taps discriminator characteristic for BOC modulation has multiple wrong stable nodes (Figure 3). To obtain the linear monotonic discriminator characteristic in the entire range of tracking error  $\tau$ , the number of taps are incorporated into correlator structure. The outputs of particular taps are then scaled by  $a(m)$  coefficients to meet this demand. The discriminator characteristic is then given by

$$S(\tau) = \sum_{m=1}^{2N} a(m) |R(\tau + (m - N + 0.5)D)|^2, \quad (4)$$

where the  $N$  is the number of couples of taps. In comparison to early late structure, this correlator has worse sensitivity.

## 5. PROPOSED BOC CORRELATOR

The aim of the development of the new correlator is to find such a correlator that fully utilize the BOC modulation benefits and is not sensitive to the false node tracking. The developed correlator should have two outputs; first output should be equal to the tracking error of coherent processing of BOC modulated signal and the second one should compare envelopes of correlation or similar product which has only one stable tracking node.

The first section of the correlator is comprised of the BOC delay correlator (Figure 1). The second section is a

sum of the both side-band early minus late discriminators  $D_U(\tau)$  and  $D_L(\tau)$  which is derived from side-band correlators outputs  $R_U(\tau)$  and  $R_L(\tau)$  (Figure 7).

The upper-side-band correlator  $R_U(\tau)$  gives correlation between received BOC modulated signal  $c_{N,M}(t)$  and spectrally shifted PRN code  $x_{N,M}(t)$ ,

$$x_{N,M}(t) = c(\lfloor Nf_0 t \rfloor) \cdot e^{j2\pi Mf_0 t}. \quad (5)$$

The BOC modulated signal can be decomposed to Fourier series as follows

$$\begin{aligned} c_{M,N}(t) &= \\ &= \frac{2}{\pi} c(\lfloor Nf_0 t \rfloor) \cdot \sum_{n=-\infty}^{\infty} \frac{-j \operatorname{sgn}(2n+1)}{2n+1} e^{j2\pi(2n+1)Mf_0 t} = \\ &= \frac{2}{\pi} \sum_{n=-\infty}^{\infty} \frac{-j \operatorname{sgn}(2n+1)}{2n+1} x_{N,(2n+1)M}(t). \end{aligned} \quad (6)$$

We can resolve this situation in frequency domain

$$\begin{aligned} F[c_{M,N}(t)] &= \\ &= \frac{2}{\pi} \sum_{n=-\infty}^{\infty} \frac{-j \operatorname{sgn}(2n+1)}{2n+1} X_N(2\pi Mf_0(2n+1)) \end{aligned} \quad (7)$$

where  $X_N(\omega)$  is spectrum of the PRN code with chip-rate  $Nf_0$ .

The signal  $\frac{-j \operatorname{sgn}(2n+1)}{2n+1} x_{N,(2n+1)M}$  is one of the PRN components of the BOC modulated signal. Due to the limited (however non-zero) cross-correlation between  $x_{N,(2i+1)M}$  and  $x_{N,(2j+1)M}$ ,  $i \neq j$ , the proposed upper sideband correlator  $R_U(\tau)$  estimates cross-correlation between spectrally shifted PRN code  $x_{N,M}(t)$  and related component  $\frac{2}{\pi} x_{N,M}$  of the received signal. The correlator output  $R_U(\tau)$  is given by

$$R_U(\tau) = \frac{2}{\pi} R_N(\tau) + \varepsilon(\tau), \quad (8)$$

where the  $R_U(\tau)$  is an autocorrelation function of PRN code with chip-rate  $Nf_0$  and component  $\varepsilon(\tau)$  covers the cross-correlation remainder of other signal components  $w_{N,M}(t)$

$$\begin{aligned} w_{N,M}(t) &= \frac{2}{\pi} \sum_{\substack{n=-\infty \\ n \neq 0}}^{\infty} \frac{-j \operatorname{sgn}(2n+1)}{2n+1} x_{N,(2n+1)M}(t) = \\ &= c_{M,N}(t) - \frac{2}{\pi} x_{N,M}, \end{aligned} \quad (9)$$

$$\varepsilon(\tau) = \int_{T_1} c_{M,N}(t+\tau) w_{N,M}^*(t) dt . \quad (10)$$

Analogically, the lower-size-band correlation is given by

$$R_L(\tau) = \frac{2}{\pi} R_N(\tau) + \varepsilon^*(\tau) . \quad (11)$$

The output of discriminator second section  $D_2(\tau)$  summarizes the sideband outputs  $D_U(\tau)$  and  $D_L(\tau)$ . Suitability of discriminator characteristic is conditioned by monotony of the  $R_U(\tau)$  and  $R_L(\tau)$  sides. It depends

mainly on the relationship of the wanted correlation  $\frac{2}{\pi} R_N(\tau)$  and the parasitic correlation  $\varepsilon(\tau)$ . The situation is much better for higher order BOC modulation ( $M \gg N$ ).

Thus, this correlator (Figure 7) has been designed and simulated. The calculated discriminator characteristic of the correlator for low order modulation BOC(1,1) is shown on the Figure 8. The discriminator characteristic of the proposed correlator has only one stable node, which is convenient.

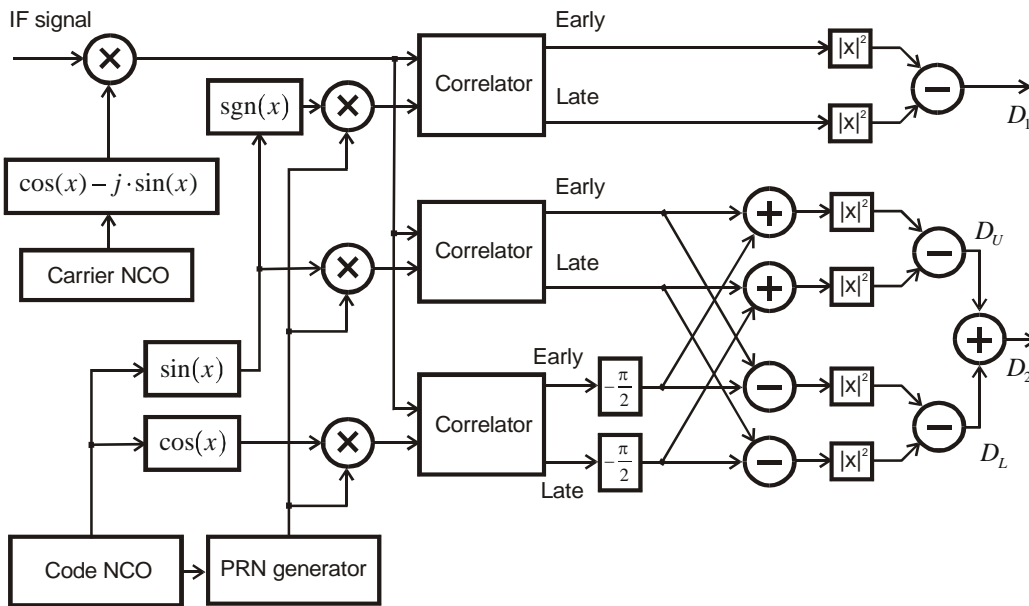

Figure 7. Proposed BOC correlator.

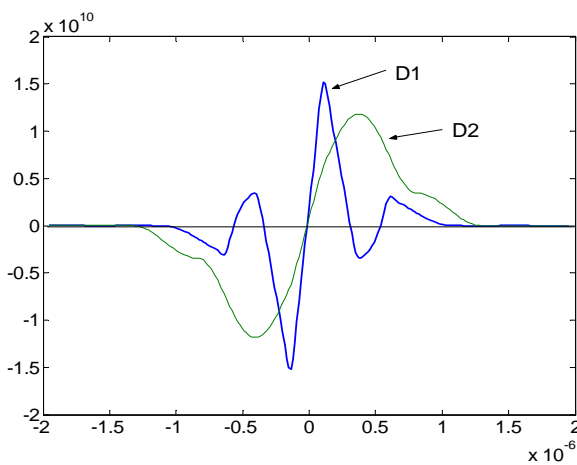

Figure 8. Discriminator characteristic for BOC(1,1) modulation

In the frame of GARDA project described BOC correlator is planned to be investigated and tested in GRANADA Galileo system simulator. For example, the

sophisticated method of combining information from both correlator outputs should be developed and tested.

## 6. CONCLUSIONS

The Galileo receiver development is carried out in the frame of GARDA project. The project is financed by the GJU (Galileo Joint Undertaking) in the frame of the Galileo R&D activities under the EC 6<sup>th</sup> Framework Program. The key technologies concerning Galileo receiver and Galileo correlators are developed. The Czech Technical University is GARDA project consortium member with responsibility for the Galileo code and carrier tracking problems.

The Galileo system uses some modern sophisticated modulation schemes based on the BOC modulation. The correlation function of the BOC modulated signal has several correlation peaks, which cause the problem of detection of the correct one. In the frame of the project

the new correlator for processing the BOC modulated signal has been developed. The developed correlator has two delay discriminator outputs: the first for fine tracking and the second based on comparison of the correlation function envelope power. The discriminator characteristic has only one stable node and serves for the detection of incorrect tracking node. The correlator is planned to be tested with the GRANADA tool.

## REFERENCES

- Barker B.; Betz J.; Clark J.; Correia J.; Gillis J.; Lazar S.; Rehorn K.; Straton J. (2002): *Overview of the GPS M Code Signal* [online], MITRE Technical Papers Archive, [cit. 2004-11-04] [http://www.mitre.org/work/tech\\_papers/tech\\_papers\\_00/betz\\_overview/betz\\_overview.pdf](http://www.mitre.org/work/tech_papers/tech_papers_00/betz_overview/betz_overview.pdf)
- Fante R. (2003): *Unambiguous Tracker for GPS Binary-Offset-Carrier Signals* [online], MITRE Technical Papers Archive, [cit. 2004-11-04] [http://www.mitre.org/work/tech\\_papers/tech\\_papers\\_03/fante\\_tracker/fante.pdf](http://www.mitre.org/work/tech_papers/tech_papers_03/fante_tracker/fante.pdf)
- Fine P.; Wilson W. (1999): *Tracking Algorithm for GPS Offset Carrier Signals* Proceedings of ION 1999 National Technical Meeting, Institute of Navigation, January 1990. 671–676.